



Dura-Ware® 2120 Series
Siphon Jet Toilet - On Floor - Floor Outlet



2120-W-3

Fixture May Show Some Available Options

Please visit www.acorneng.com for most current specifications.

Siphon Jet Toilet - On Floor - Floor Outlet

Fixture is arranged to be installed on finished wall from the front side. It is fabricated from 16 gage, type 304 stainless steel and is seamless welded construction. Exterior has a satin finish with an integral contoured seat. The inside of the toilet bowl also has a satin finish. Wall flange is reinforced for maximum strength.

Toilet is Siphon Jet type with elongated bowl manufactured to ANSI 112.19.2M requirements. Toilet has a 1-1/2" NPT flush valve connection and requires a minimum of 25 PSI flow pressure. Toilet uses a minimum water consumption of 1.6 gallons per flush. Trap has a minimum 3-1/2" seal, will pass a 2-1/8" ball and is fully enclosed. Toilet waste outlet is gasketed waste.

GUIDE SPECIFICATION

Provide and install Acorn Dura-Ware Siphon Jet Toilet (specify model number and options). Fixture shall be fabricated from 16 gage, type 304 stainless steel. Construction shall be seamless welded and exposed surfaces shall have a satin finish with an integral contoured toilet seat. Toilet shall be concealed siphon jet type with an elongated bowl and a self-draining flushing rim. Toilet shall meet ANSI 112.19.2M requirements, using a minimum average water consumption of 1.6 gallons per flush. Toilet trap shall have a minimum 3-1/2" seal that shall pass a 2-1/8" diameter ball and be fully enclosed. Toilet waste outlet shall be gasketed waste.



Dura-Ware®: 2120 Siphon Jet Toilet - On Floor - Floor Outlet

WALL THICKNESS AND TYPE (Must Specify)

Thickness _____ Type _____

MODEL NUMBER AND OPTIONS SELECTION

BASE MODEL NUMBER

- 2120 Siphon Jet Toilet

SUPPLY (Must Specify)

- T Top (Exposed)
 - W Wall (Concealed)

FIXTURE MOUNTING AND WASTE (Must Specify)

- 3 On-Floor, Floor Outlet

FLUSH VALVE GPF'S (Must Specify)

- 1.6 GPF
 - 3.5 GPF

FLUSH VALVE OPTIONS (Must Specify)

- Flush Valve by Others
 - EVSFV Master-Trol Flush Valve (N/A for Top Supply)
 - FV Flush Valve (N/A for ADA)
 - FVC Cover, Flush Valve (N/A for ADA)
 - FVCH Cover, Hydraulic Flush Valve
 - FVH Flush Valve, Hydraulic
 - FVL Flush Valve, Lever Handle
 - MVCFV Time-Trol Flush Valve (N/A for Top Supply)

Product Options

- ADA 18" Integral Seat Height
 - BCN Blind Cap Nuts (2)
 - BL Bedpan Lugs
 - CN Cap Nuts (2)
 - EG Enviro-Glaze: Specify Color: _____
 - Exterior Only (Not Inside Bowl)
 - Exterior & Inside Bowl
 - FG 14 Gage Housing
 - FT Flood-Trol (N/A for Top Supply)
 - FTA Flood-Trol Auto-Reset (N/A for Top Supply)
 - FVT Flush Valve Thru Wall Connection
 - HPS High Polish Integral Seat
 - HS Hinged Seat, Open Front Less Cover
 - HSC Hinged Seat w/ Cover
 - PFS Punched for Seat by Others
 - PH Paper Holder (Available Only with -FVC)
 - TF Transformer, 120VAC to 24VAC
 - TSC Toilet Shipping Cover
 - VAC AcornVAC System
 - WO3 3" O.D. Toilet Waste Outlet (3.5 GPF Only)

Please visit www.acorneng.com for most current specifications.

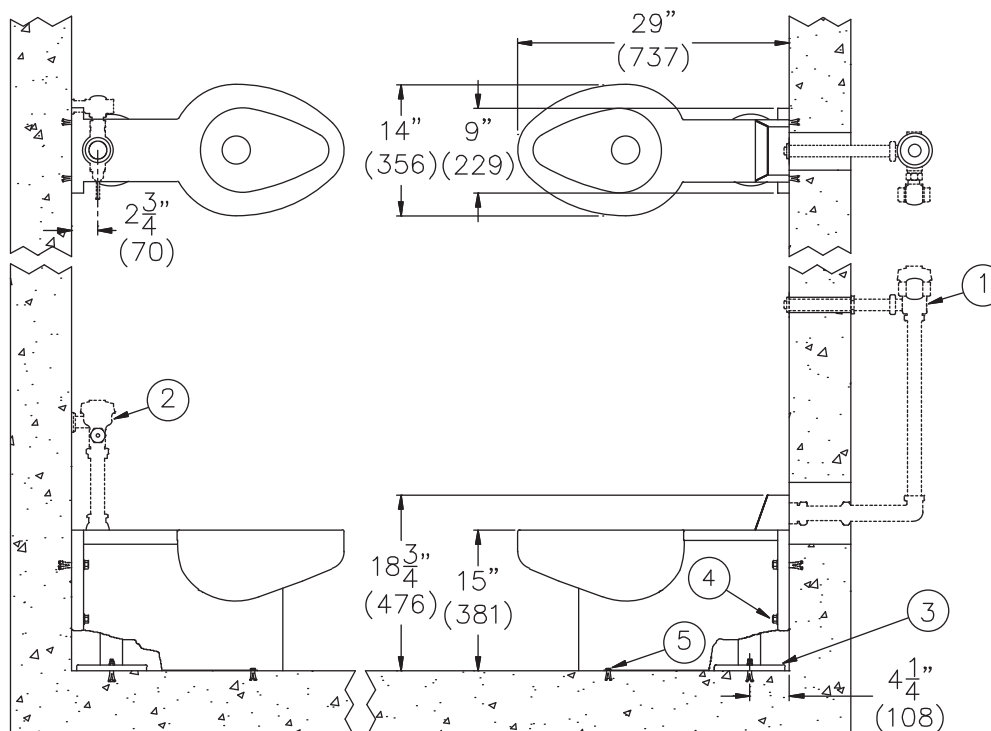

- NOTES:
- 1. Optional -FV Flush Valve - Wall Supply.
 - 2. Optional -FV Flush Valve - Top Supply.
 - 3. Toilet Floor Waste Outlet.
 - 4. Wall Fasteners.
 - 5. Floor Fasteners.

Important: Installation instructions and current rough-in are furnished with each fixture. Do not rough in without certified dimensions. Dimensions are subject to manufacturer's tolerance of plus or minus 1/4" and change without notice. Acorn assumes no responsibility for use of void or superseded data. © Copyright 2006 Acorn Engineering Company	
<p style="text-align: center;">Selection Summary</p> <p>Model No. & Option _____</p> <p>Quantity _____</p>	<p style="text-align: center;">Approved for Manufacturing</p> <p>Company _____ Title _____</p> <p>Signature _____ Date _____</p>