



## Dura-Ware® 2167 Series

Straddle Type Washout Urinal - ADA Compliant



2167-T-1-FV

2167-W-1-FV-2898

Fixture May Show Some Available Options

Please visit [www.acorneng.com](http://www.acorneng.com) for most current specifications.

### Straddle Type Washout Urinal - ADA Compliant

**Fixture** is arranged to be installed on finished wall and serviced from the front side. Unit conforms with ANSI, UFAS and ADA requirements for accessibility. Compliance is subject to the interpretation and requirements of the local code authority. Fixture is fabricated from 16 gage, type 304 stainless steel and is seamless welded construction. Exterior has a satin finish. Interior has a matte finish. Fixture has a back wall washdown, and is optionally available with a continuous flushing rim that washes all four walls. Corners are coved to facilitate cleaning. P-trap is fully enclosed. Back of fixture is sound-deadened with fire-resistant material.

**Urinal** is washout type with back wall washdown. Flushing inlet connection is 3/4" NPT male. Bottom of urinal is sloped to a high capacity stainless steel beehive dome strainer. Strainer is secured with tamper-resistant screws. P-trap has minimum of 2" seal.

**Exposed Mounting Screws** are furnished. No concealed wall fasteners or anchor shields are furnished.

#### GUIDE SPECIFICATION

Provide and install Acorn Dura-Ware Straddle Type Washout Urinal (specify model number and options). Urinal shall be back wall washdown type. Fixture shall be fabricated from 16 gage, type 304 stainless steel and shall have coved corners to facilitate cleaning. All welds shall be continuous and exterior surfaces shall have a satin finish. P-trap shall be fully enclosed. Fixture shall be furnished with exposed mounting screws. Units to conform with ANSI, UFAS and ADA requirements for accessibility.

# Dura-Ware® 2167: Straddle Type Washout Urinal - ADA Compliant



## WALL THICKNESS AND TYPE (Must Specify)

Thickness \_\_\_\_\_ Type \_\_\_\_\_

## MODEL NUMBER AND OPTIONS SELECTION

### BASE MODEL NUMBER

2167 Straddle Type Washout Urinal

### SUPPLY (Must Specify)

- T Top (Exposed)
- W Wall (Concealed)

### FIXTURE MOUNTING AND WASTE (Must Specify)

- 1 Off-Floor, Wall Outlet

### Product Options

- ADA 17" Rim Height
- CFR Continuous Flushing Rim
- EG Enviro-Glaze Color, Specify: \_\_\_\_\_
- FG 14 Gage Housing
- FV Flush Valve \_\_ 1.0 GPF \_\_ 1.5 GPF
- FVC Flush Valve Cover (w/Flush Valve) \_\_ 1.0 GPF \_\_ 1.5 GPF
- FVT Flush Valve Thru Wall Connection
- WA1 Waste Adapter to 2" NCT Female
- WA2 Waste Adapter to 2" NPT Male
- WA3 Waste Adapter to 2" NPT Female
- WA4 Waste Adapter to 2" No-Hub

Please visit [www.acorneng.com](http://www.acorneng.com) for most current specifications.

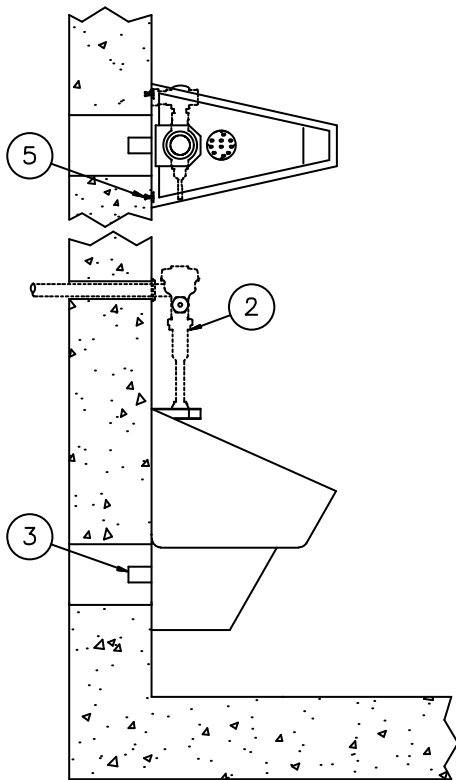

2167-T-1

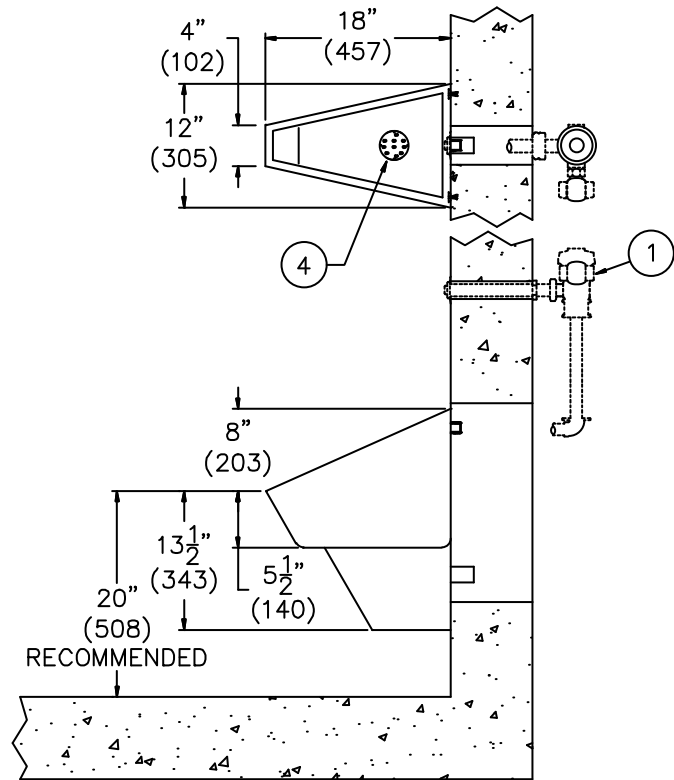

2167-W-1

### NOTES:

1. Optional -FV Flush Valve - Wall Supply. 4. Beehive Strainer.
2. Optional -FV Flush Valve - Top Supply. 5. Wall Mounting Anchors (By Others).
3. Urinal Waste Outlet.

<b>Important:</b> Installation instructions and current rough-in are furnished with each fixture. Do not rough in without certified dimensions. Dimensions are subject to manufacturer's tolerance of plus or minus 1/4" and change without notice. Acorn assumes no responsibility for use of void or superseded data. © Copyright 2007 Acorn Engineering Company	
<p style="text-align: center;">Selection Summary</p> <p>Model No. &amp; Option _____</p> <p>Quantity _____</p>	<p style="text-align: center;">Approved for Manufacturing</p> <p>Company _____ Title _____</p> <p>Signature _____ Date _____</p>