



Meridian 2155 Series

Meridian Washout Urinal



2155-T-1-FM

Fixture May Show Some Available Options

Please visit www.acorneng.com for most current specifications.

Meridian Washout Urinal

Meridian Washout Urinals are engineered to combine attractive looks, vandal resistance and versatility. Urinals feature a contoured interior to facilitate cleaning and are optionally available with a High Polish Finish (-HP) for an exceptional, elegant appearance. Mounting is available for front or rear installations. Urinals mounted at 17" rim height comply with ANSI, ADA and UFAS accessibility requirements. Compliance is subject to the interpretation and requirements of the local code authority.

Housing is heavy gage, type 304 stainless steel with exterior surfaces polished to a satin finish. Unit includes an enclosed bottom. Front mount units come with a removable bottom access cover.

Urinal is a washout type with chrome plated exposed flush fitting and beehive dome strainer. P-trap has a minimum of 2" seal.

Flush Valve supply is available for exposed or concealed flush valve styles. Minimum required flow pressure is 25 PSI.

Front Mount (-FM) units include a fixture to wall mounting plate with exposed vandal-resistant fasteners. Mounting plate is mounted directly to reinforced wall.

Rear Mount (-RM) units include integral 1/2" UNC anchor tappings and mounting hardware. Unit requires an accessible pipe chase for installation.

GUIDE SPECIFICATION

Provide Acorn Meridian Stainless Steel Washout Urinal (specify model number and options). Urinal mounted at 17" rim height to comply with ANSI, ADA and UFAS accessibility requirements. Urinal shall be washout type. Fixture shall be fabricated of heavy gage type 304 stainless steel with exposed surfaces polished to a satin finish. Interior to have a contoured surface to facilitate cleaning. Provide chrome plated exposed flush fitting and beehive dome strainer. Bottom shall be enclosed.



Meridian: 2155 Meridian Washout Urinal

MODEL NUMBER AND OPTIONS SELECTION

WALL THICKNESS AND TYPE (Must Specify)

Thickness _____ Type: ___Concrete___Block___Steel

BASE MODEL NUMBER

-2155 Meridian Washout Urinal

SUPPLY SELECTION (Must Specify)

-T Top (Exposed)
 -W Wall (Concealed)

FIXTURE MOUNTING & WASTE (Must Specify)-1 Off-

-1 Off-Floor, Wall Outlet

INSTALLATION (Must Specify)

-FM Front Mount
 -RM Rear Mount

Product Options

- ADA 17" Rim Height
- EG Enviro-Glaze (Cabinet/Counter) Color: ___-___
- FV Flush Valve (1.0 GPF)
- FVC Flush Valve Cover (Includes 1.0 GPF Flush Valve)
- FVT Flush Valve Thru-Wall Connection
- HP High Polish Finish
- SW Wall Sleeve (-RM Models Only)

Please visit www.acorneng.com for most current specifications.

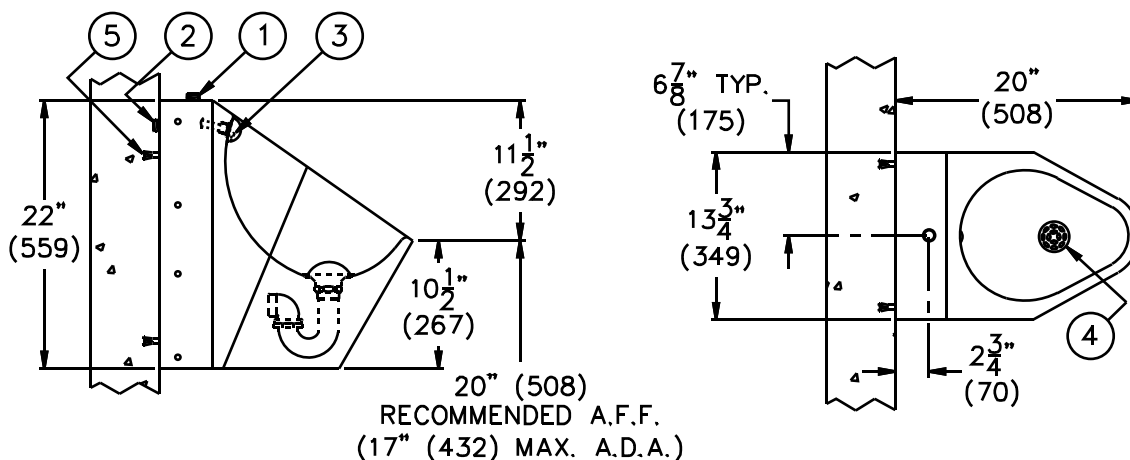

RECOMMENDED A.F.F.
 (17" (432) MAX. A.D.A.)

MODEL# 2155-T/W-1-FM Series

NOTES:

- 1. Top Supply Flushing Inlet.
- 2. Wall Supply Flushing Inlet.
- 3. Exposed Flush Fitting.
- 4. Beehive Strainer.
- 5. Wall Mounting Anchors.
(By Others)

Important: Installation instructions and current rough-in are furnished with each fixture. Do not rough in without certified dimensions. Dimensions are subject to manufacturer's tolerance of plus or minus 1/4" and change without notice. Acorn assumes no responsibility for use of void or superseded data. © Copyright 2004 Acorn Engineering Company	
<p style="text-align: center;">Selection Summary</p> <p>Model No. & Option _____</p> <p>Quantity _____</p>	<p style="text-align: center;">Approved for Manufacturing</p> <p>Company _____ Title _____</p> <p>Signature _____ Date _____</p>