



Penal-Ware® 1670FA Series

Drinking Fountain - Front Access



1670-FA-1-BP-3

Fixture May Show Some Available Options

Please visit www.acorneng.com for most current specifications.

Drinking Fountain - Front Access

Fixture is arranged to be installed on finished wall through a removable bottom panel secured with tamper-resistant screws. For locating or providing required wall openings and mounting points the optional wall sleeve or metal template is recommended. Fixture is fabricated from 14 gage, type 304 stainless steel and is seamless welded construction with a satin finish. Cabinet interior is sound-deadened with fire-resistant material. Exterior is polished to a satin finish.

Countertop has a deck mounted bubbler.

Bowl is oval. Standard P-trap waste outlet is 1-1/2" O.D. plain end and extends 3" minimum beyond the back of the fixture.

Optional Valve is an Air-Control pneumatically operated, pushbutton valve using atmospheric air. Pushbutton is vandal-resistant and requires less than 5 pounds to activate valve. Valve is direct acting, non-metering type. Valve includes a 0.7 GPM flow. Valve conforms with the lead free requirements of NSF 61, Section 9-1997.

Regularly Furnished items include a removable P-trap, a fast drain, and mounting hardware.

GUIDE SPECIFICATION

Provide and install Acorn Penal-Ware Drinking Fountain - Front Access (specify model number and options). Fixture shall be fabricated from 14 gage, type 304 stainless steel. Cabinet bottom shall be removable and secured with tamper-resistant screws. Construction shall be seamless welded and exposed surfaces shall have a satin finish. Cabinet interior is sound-deadened with fire-resistant material. Fixture shall be furnished with, a removable P-trap and necessary fasteners for proper installation. Valve to conform with NSF 61, Section 9-1997 lead-free requirements.



Penal-Ware®: 1670FA Drinking Fountain - Front Access

WALL THICKNESS AND TYPE (Must Specify)

Thickness _____ Type: ___ Concrete ___ Block ___ Steel

MODEL AND OPTIONS SELECTION

BASE MODEL NUMBER

-1670-FA Drinking Fountain - Front Access

FIXTURE MOUNTING AND WASTE (Must Specify)

-1 Off-Floor, Wall Outlet

BUBBLER SELECTION (Must Specify)

- BC Bubbler, Code
- BP Bubbler, Penal
- BPH Bubbler, Hemispherical

VALVE SELECTION (Must Specify)

- 03 Air-Control, Single Temperature
- 09 Punched for Valve by Others (Specify Punching)
- EVS1 Electronic Valve System - Single Temp
- MVC1 Time-Trol - Single Temp
- MVC1-BAT Time-Trol - Single Temp Battery Operation

Product Options

- EG Enviro-Glaze, Specify Color: _____
- FMT Fixture Mounted Trim
- LWE Lavy Waste Extended Beyond Standard 3"
- MT Metal Template
- PBH Hemispherical Pushbutton
- SW Wall Sleeve
- TF Transformer (for up to 12 solenoids)
- TG 12 Gage Cabinet
- VAC Acorn-Vac System

Please visit www.acorneng.com for most current specifications.

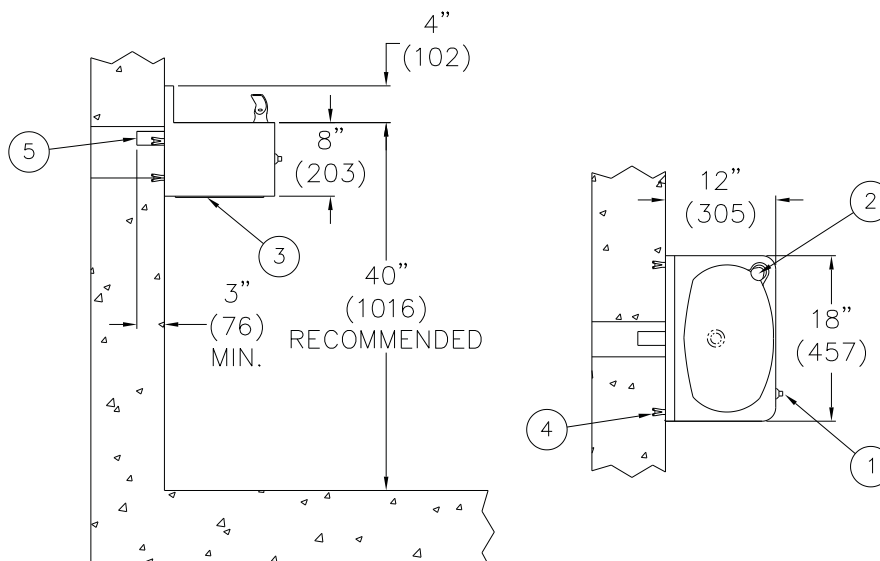

1670-FA-1-BP-03

NOTES:

1. Valve Pushbutton.
2. Deck Mounted Bubbler.
3. Access Panel.
4. Wall Mounting Anchors (By Others).
5. Lavy Waste Outlet.

Important: Installation instructions and current rough-in are furnished with each fixture. Do not rough in without certified dimensions. Dimensions are subject to manufacturer's tolerance of plus or minus 1/4" and change without notice. Acorn assumes no responsibility for use of void or superseded data. © Copyright 2004 Acorn Engineering Company	
<p style="text-align: center;">Selection Summary</p> <p>Model No. & Option _____</p> <p>Quantity _____</p>	<p style="text-align: center;">Approved for Manufacturing</p> <p>Company _____ Title _____</p> <p>Signature _____ Date _____</p>