



Penal-Ware® 1707 Series

Straddle - Washout Urinal - ADA Compliant



1707-T-1-FV

1707-W-1

Fixture May Show Some Available Options

Please visit www.acorneng.com for most current specifications.

Straddle - Washout Urinal - ADA Compliant

Fixture is arranged to be installed on finished wall and serviced from an accessible pipe chase. Optional Wall Sleeve or Metal Template is recommended for all installations for required wall openings. Unit conforms with ANSI, UFAS and ADA requirements for accessibility. Compliance is subject to the interpretation and requirements of the local code authority. Fixture is fabricated from 14 gage, type 304 stainless steel and is seamless welded construction. Exterior has a satin finish. Interior has a matte finish. Fixture is back wall washdown type, and is optionally available with a continuous flushing rim that washes all four walls. Corners are coved to facilitate cleaning. P-trap is fully enclosed. Back of fixture is sound-deadened with fire-resistant material. There are no accessible voids or crevices where contraband can be concealed.

Urinal is washout type. Flushing connection is 3/4" NPT male. Bottom is sloped to an integrally welded high capacity stainless steel beehive dome strainer. P-trap has a minimum of 2" seal.

Mounting Hardware is furnished for walls up to 8" thick.

GUIDE SPECIFICATION

Provide and install Acorn Penal-Ware Straddle - Washout Urinal (specify model number and options). Urinal shall be back wall washdown type. Fixture shall be fabricated from 14 gage, type 304 stainless steel and shall have coved corners to facilitate cleaning. Bottom shall be sloped to an integrally welded high capacity stainless steel beehive dome strainer. Construction shall be seamless welded and exterior surfaces shall have a satin finish. P-trap shall be fully enclosed. Fixture shall be furnished with necessary fasteners for proper installation. Units to conform with ANSI, UFAS and ADA requirements for accessibility.



Penal-Ware®: 1707 Straddle-Washout Urinal - ADA Compliant

WALL THICKNESS AND TYPE (Must Specify)

Thickness _____ Type: ___ Concrete ___ Block ___ Steel

MODEL NUMBER AND OPTIONS SELECTION

BASE MODEL NUMBER

-1707 Straddle - Washout Urinal

SUPPLY (Must Specify)

-T Top (Exposed)
 -W Wall (Concealed)

FIXTURE MOUNTING AND WASTE (Must Specify)

-1 Off-Floor, Wall Outlet

FLUSH VALVE GPFs (Must Specify)

-1.0 GPF
 -1.5 GPF

FLUSH VALVE OPTIONS (Must Specify)

-Flush Valve By Others
 -EVSFV Master-Trol Flush Valve (N/A for Top Supply)
 -FV Flush Valve (N/A For ADA)
 -FVC Cover, Flush Valve (N/A For ADA)
 -FVCH Cover, Hydraulic Flush Valve
 -FVH Flush Valve Hydraulic
 -FVL Flush Valve Lever Handle
 -MVCFV Time-Trol Flush Valve (N/A for Top Supply)

Product Options

-ADA ADA Compliant - 17" Rim Height
 -CFR Continuous Flushing Rim
 -EG Enviro-Glaze, Specify Color: _____
 -FVT Flush Valve Thru Wall Connector
 -MT Metal Template (Only 1 Required Per Project)
 -SW Wall Sleeve
 -TF Transformer, 120VAC to 24VAC
 -TG Twelve Gage Housing

Please visit www.acorneng.com for most current specifications.

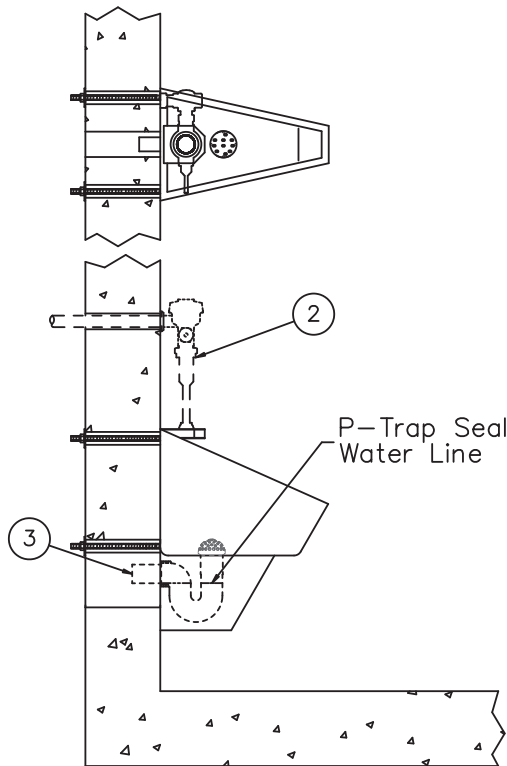

1707-T-1

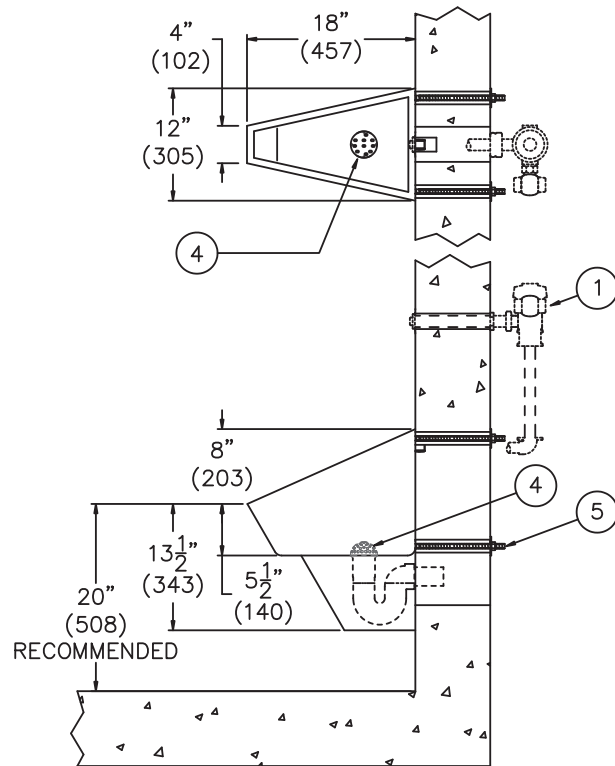

1707-W-1

NOTES:

1. Optional -FV Flush Valve - Wall Supply.
2. Optional -FV Flush Valve - Top Supply.
3. Urinal Waste Outlet.
4. Beehive Strainer.
5. Wall Mounting Hardware.

<p>Important: Installation instructions and current rough-in are furnished with each fixture. Do not rough in without certified dimensions. Dimensions are subject to manufacturer's tolerance of plus or minus 1/4" and change without notice. Acorn assumes no responsibility for use of void or superseded data. © Copyright 2006 Acorn Engineering Company</p>	
<p>Selection Summary</p> <p>Model No. & Option _____</p> <p>Quantity _____</p>	<p>Approved for Manufacturing</p> <p>Company _____ Title _____</p> <p>Signature _____ Date _____</p>