



Penal-Ware® 1741ADAF A Series

Penal-Pak Wall Shower, Front Access - ADA Compliant



1741-ADA-FA-3

Fixture May Show Some Available Options

Please visit www.acorneng.com for most current specifications.

Penal-Pak Wall Shower, Front Access - ADA Compliant

Shower is designed to be installed on a finished wall and serviced through removable front panel. Mounting frame is provided. Fixture is fabricated from 14 gage, type 304 stainless steel and the exterior has a satin finish. Unit conforms with ANSI, UFAS and ADA requirements for accessibility. Compliance is subject to the interpretation and requirements of the local code authority.

Shower Head. There are two heads provided:

1. The fixed head is vandal-resistant. The spray pattern can only be changed by the use of an allen wrench inserted through the nozzle.
2. The hand shower includes a 60" long, stainless steel hose, hand spray, vacuum breaker, quick disconnect and mounting bracket. Unit is optionally available with suffix option -FH Fixed Head mounted at 48" in lieu of handshower.

Valves (ADA compliant) available are:

1. Air control pushbutton valves using atmospheric air; metering non-hold open type. Timing is from 5 to 60 seconds. Air control valves can be remotely located up to 10 feet from the operating pushbutton.
2. Electronic valve system using Modular Valve Controller for water metering through precise electronic control of a solenoid valve. Valve timing is from 1 second to 9 minutes. Modular Valve Controller can be remotely located up to 100 feet from the operating pushbutton.

Regularly furnished items include an ADA compliant control valve, a shower head, a hand shower with quick disconnect and mounting bracket, a recessed soap dish, mounting frame and hardware. Grab bar and folding seat by others.

GUIDE SPECIFICATION

Provide and install an Acorn Penal-Ware, ADA Compliant, Front Access Wall Shower (specify model number and options). Shower panel shall be fabricated from 14 gage, type 304 stainless steel and shall have a satin finish. Exposed trim shall be chrome-plated brass. Fixture shall be furnished with a fixed shower head, a hand shower with vacuum breaker, quick disconnect and mounting bracket. Shower shall be provided with an ADA compliant control valve. A stainless steel recessed soap dish shall be factory welded in place. Fixture shall be provided with necessary fasteners for proper installation. Units to conform with ANSI, UFAS and ADA requirements for accessibility.

Penal-Ware®: 1741ADAF A Penal-Pak Wall Shower, Front Access - ADA Compliant



WALL THICKNESS AND TYPE (Must Specify)

Thickness _____ Type _____

MODEL NUMBER AND OPTIONS SELECTION

BASE MODEL NUMBER

- 1741-ADA-FA Penal-Pak Wall Shower - ADA Compliant - Front Access

Product Options

- CSH Conical Shower Head
- EG Enviro-Glaze, Specify Color: _____
- F Flow Control 2.0 GPM
- FH Fixed Head at 48" in Lieu of Hand Shower
- PBH Hemispherical Pushbutton
- SSV Space Saver Showerhead 20°Discharge

VALVE SELECTION (Must Specify)

- 3 Air-Control, Single Temperature
- 4 Air-Control, Hot & Cold
- EVS1 Electronic Valve System - Single Temp
- EVS2 Electronic Valve System - Hot & Cold
- MVC1 Time-Trol - Single Temp
- MVC2 Time-Trol - Hot & Cold

Please visit www.acorneng.com for most current specifications.

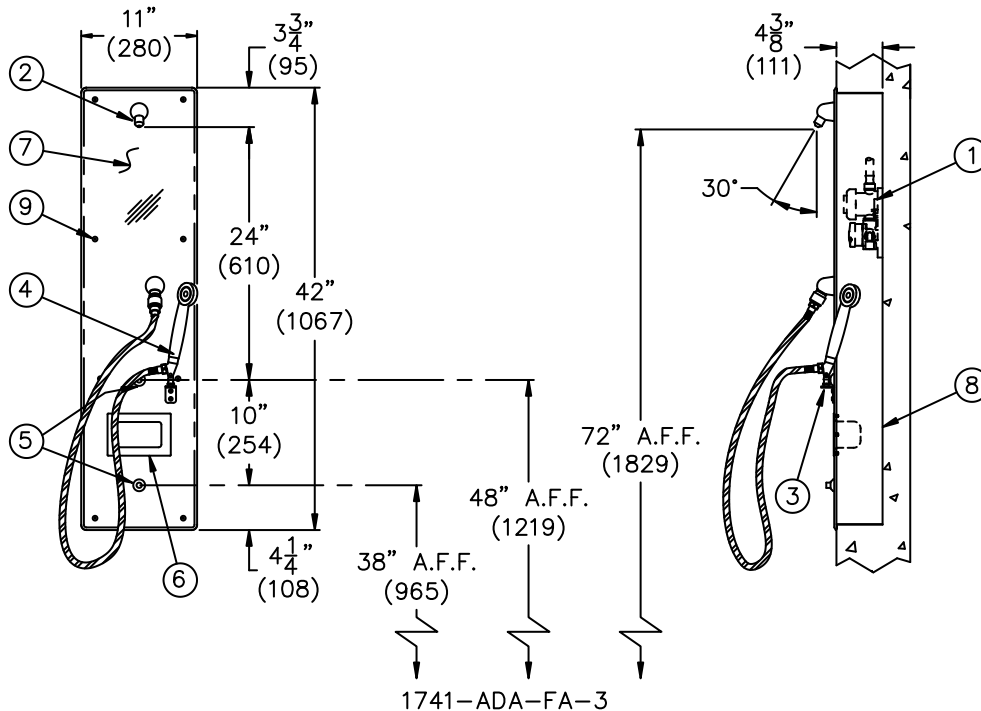

NOTES:

- 1. Optional -3 Air-Control Valve.
- 2. Penal Shower Head.
- 3. Hand Shower Mounting Bracket.
- 4. Hand Shower with Quick Disconnect.
- 5. Control Valve Pushbuttons.
- 6. Recessed Soap Dish.
- 7. Shower Panel.
- 8. Wall Mounting Frame.
- 9. Tamper Resistant Screws.

| | |
|---|--|
| <p>Important: Installation instructions and current rough-in are furnished with each fixture. Do not rough in without certified dimensions. Dimensions are subject to manufacturer's tolerance of plus or minus 1/4" and change without notice. Acorn assumes no responsibility for use of void or superseded data. © Copyright 2007 Acorn Engineering Company</p> | |
| <p style="text-align: center;">Selection Summary</p> <p>Model No. & Option _____</p> <p>Quantity _____</p> | <p style="text-align: center;">Approved for Manufacturing</p> <p>Company _____ Title _____</p> <p>Signature _____ Date _____</p> |