

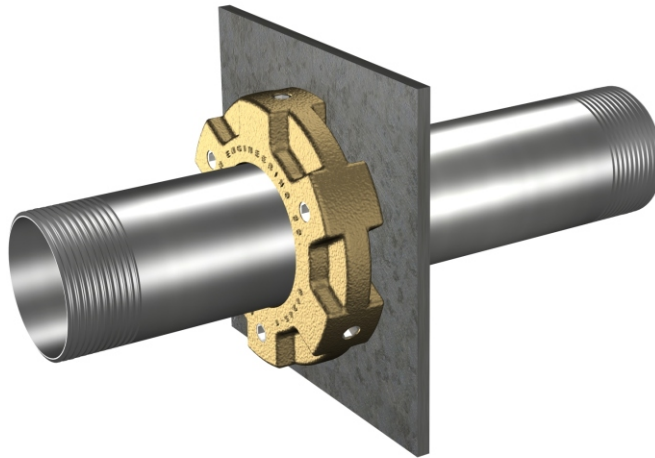

## 3395 Series

Anchoring Assembly - Replacement



3395

Fixture May Show Some Available Options

Please visit [www.acorneng.com](http://www.acorneng.com) for most current specifications.

### Anchoring Assembly - Replacement

**This Anchoring Assembly** is available for attaching to both flushing inlet fittings and lavy waste outlet fittings. It utilizes existing wall openings to securely anchor the replacement fixture to the wall.

**Regularly furnished** items include a threaded anchoring pipe for applicable wall thickness, a thrust plate, and the anchoring collar with locking adjustment screws.

#### GUIDE SPECIFICATION

Provide and install Acorn Replace-Ware Anchoring Assembly Model 3395. Product to include threaded anchoring pipe, thrust plate, anchoring collar and adjusting screws.



# Replace-Ware®: 3395 Anchoring Assembly - Replacement

**WALL THICKNESS AND TYPE (Must Specify)**  
 Thickness \_\_\_\_\_ Type: \_\_\_ Concrete \_\_\_ Block \_\_\_ Steel

**Product Options**  
 (See *Penal-Ware® Model Numbers & Options Section*)  
 - \* None Available

**MODEL NUMBER AND OPTIONS SELECTION**

**BASE MODEL NUMBER**

- 3395 Anchoring Assembly - Replacement
- 1-1/4" NPT (Lavy Waste)
- 1-1/2" NPT (Toilet Flushing Inlet)

Please visit [www.acorneng.com](http://www.acorneng.com) for most current specifications.

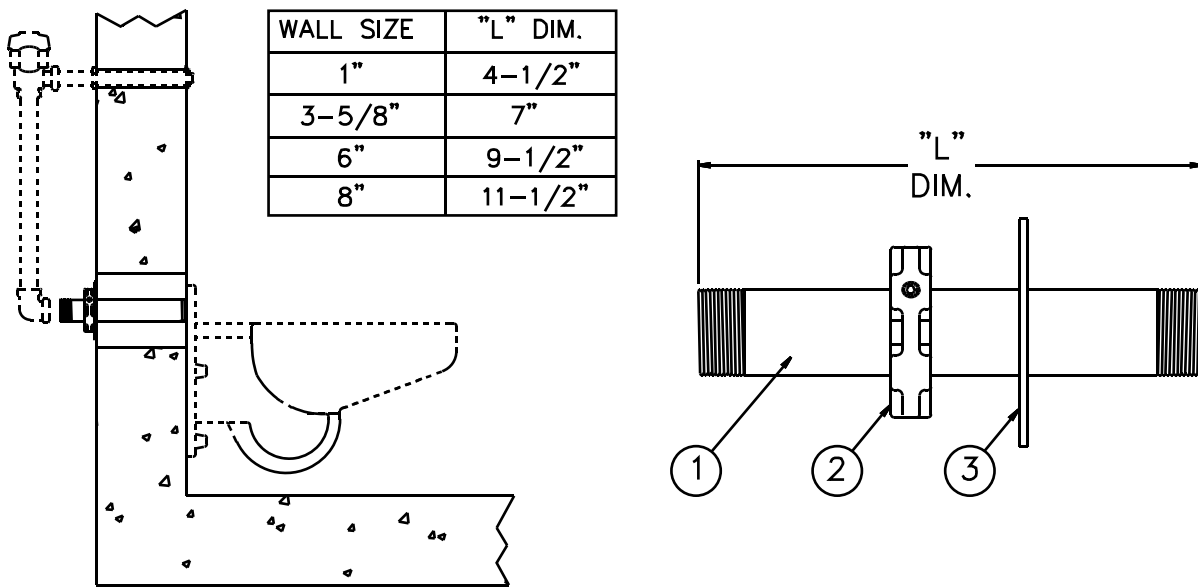

3395

**NOTES:**

1. Threaded Anchoring Pipe. 2. Anchoring Collar. 3. Thrust Plate.

<p><b>Important:</b> Installation instructions and current rough-in are furnished with each fixture. Do not rough in without certified dimensions.          Dimensions are subject to manufacturer's tolerance of plus or minus 1/4" and change without notice. Acorn assumes no responsibility for use of void or superseded data. © Copyright 2003 Acorn Engineering Company</p>	
<p style="text-align: center;">Selection Summary</p> <p>Model No. &amp; Option _____</p> <p>Quantity _____</p>	<p style="text-align: center;">Approved for Manufacturing</p> <p>Company _____ Title _____</p> <p>Signature _____ Date _____</p>