



Shower-Ware® 460MS Series

Diana Modular Privacy Compartments for Apex Type 6 Two Station Showers



461-W-MS

Fixture May Show Some Available Options

Please visit www.acorneng.com for most current specifications.

Diana Modular Privacy Compartments for Apex Type 6 Two Station Showers

- **MS** Stainless Steel Modular Privacy Compartments provide a bathing area for each shower station.

Hardware for each compartment includes posts, headrails, brackets, and escutcheons. All hardware is vandal-resistant.

Curtains are white Herculite® material.

Panels for - MS are constructed using structural honeycomb core firmly cemented to the stainless steel panels. Formed molding interlocks panel edges under tension. Corners are welded and polished.

Posts are provided with a jackscrew type leveling system which is concealed by an escutcheon.

Dressing Compartments, when required, must be shown on contract drawings. The following should be added to the base specification for Apex Type 6 Two Station Showers. Note: Submittal drawings are required by Acorn.

BRIEF SPECIFICATION

Provide and install Acorn Diana Modular Privacy Compartments (example - MS Stainless Steel) as shown on contract drawings.

DETAILED SPECIFICATION

Provide and install Acorn Diana Modular Privacy Compartments (specify type) as shown on contract drawings. Provide white Herculite® shower curtain with chrome-plated hooks for each Privacy Compartment and Dressing Compartment entrance. Each Dressing Compartment shall be equipped with Acorn chrome-plated brass double robe hook and Acorn hardwood seat with stainless steel post.



Shower-Ware® 460MS : Diana Modular Privacy Compartments for Apex Type 6 Two Station Showers

BASE MODEL NUMBER (Must Specify)

Product Options

- MS Modular Privacy Compartments (Stainless Steel)

None

Note: Factory Created Compartment Layout Required.

Please visit www.acorneng.com for most current specifications.

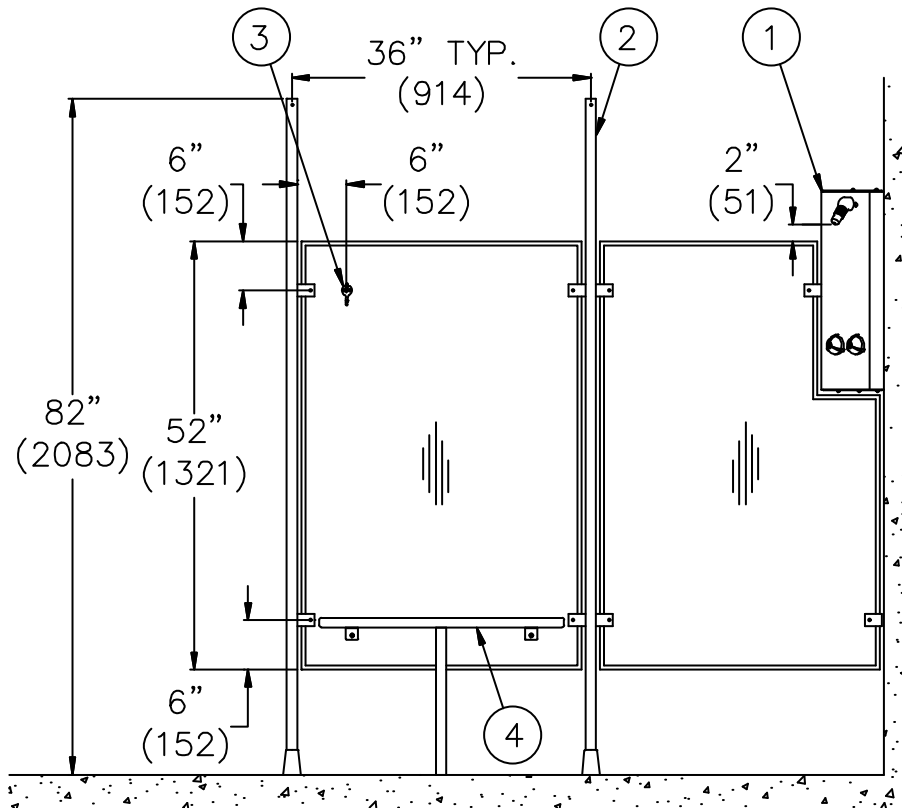

- NOTES: MODEL# 460-MS SERIES
- 1. Apex Two Station Shower.
 - 2. Post/Pilaster.
 - 3. Robe Hook.
 - 4. Teakwood Seat.

<p>Important: Installation instructions and current rough-in are furnished with each fixture. Do not rough in without certified dimensions. Dimensions are subject to manufacturer's tolerance of plus or minus 1/4" and change without notice. Acorn assumes no responsibility for use of void or superseded data. © Copyright 2007 Acorn Engineering Company</p>	
<p>Selection Summary</p> <p>Model No. & Option _____</p> <p>Quantity _____</p>	<p>Approved for Manufacturing</p> <p>Company _____ Title _____</p> <p>Signature _____ Date _____</p>

S.460MS

Revised: 5/16/07