



## Shower-Ware® 480ADA Series

Eco-Rain Apex Type 8 Surface-Mounted Showers - ADA Compliant



482-ADA-W

Fixture May Show Some Available Options

Please visit [www.acorneng.com](http://www.acorneng.com) for most current specifications.

### Eco-Rain Apex Type 8 Surface-Mounted Showers - ADA Compliant

**Shower** includes an ADA compliant control valve with lever handle or pushbutton, a Hand Shower with in-line vacuum breaker and pushbutton volume control, a 24" Glide Rail, Valve Supply Flexible Hose Connectors and a Recessed Soap Dish. Unit conforms with ANSI, UFAS and ADA requirements for accessibility. Compliance is subject to the interpretation and requirements of the local code authority.

**Housing** is 18 gage, type 304 stainless steel with satin finish.

**Reach.** All controls, soap dish, etc., must be 38" to 48" from the finished floor to be within reach of a seated bather with limited arm movement.

**Control Valve** type is indicated by selected Apex model number. Disabled bathers should be provided with protection against sudden hot or cold "shock." Pressure balancing valves such as our Safti-Trol® are often required and are strongly recommended. Safti-Trol® Hot & Cold Pressure Balancing valve has a replaceable cartridge which contains all wearing parts and comes standard with checkstops. Safti-Trol valve is tamper-resistant with an easy close mechanism. Air-Control Single Temperature valve is a pneumatically operated, pushbutton valve using atmospheric air. Pushbutton is vandal-resistant and requires less than 5 pounds to activate. Air-Control valve is metering type with non-hold open feature having adjustable timing from 5 to 60 seconds.

**Shower Head.** A shower head on a five foot hose (hand shower) is provided for seated bathers with glide rail to allow for vertical adjustment and use as a fixed head.

**Fasteners.** Acorn furnishes all exposed tamper-resistant fasteners necessary to complete the on-site shower assembly; however, concealed wall fasteners or anchor shields are not furnished.

#### GUIDE SPECIFICATION

Provide and install Acorn Eco-Rain Apex Surface-Mounted ADA Compliant Showers with Glide Rails (specify model number and options). Housing shall be 18 gage, type 304 stainless steel with satin finish. Exposed trim shall be chrome-plated brass. Fixture shall be furnished with an ADA compliant control valve with lever handle or pushbutton, hand shower with in-line vacuum breaker and pushbutton volume control, 24" glide rail and recessed soap dish. Units to conform with ANSI, UFAS and ADA requirements for accessibility. Shower shall be provided with the following optional equipment: (example -QD Quick Disconnect). Installation shall be made in accordance with manufacturer's recommendations and details.



**Shower-Ware®: 480ADA Econ-Rain Apex Type 8 Surface-Mounted Showers - ADA Compliant**

**MODEL NUMBER AND OPTIONS SELECTION**

**SERIES (Must Specify)**

-4 - Apex

**TYPE (Must Specify)**

-8 Eco-Rain Surface-Mounted Showers

**VALVE SELECTION (Must Specify)**

-2 ADA Safti-Trol, H & C Pressure Balancing

-6 ADA Air-Control, Single Temperature Metering

**SUPPLY (Must Specify)**

-W Wall

**Product Options**

-G Individual Stops

-GX Individual Check stops

-QD Quick Disconnect for Hand Shower

Please visit [www.acorneng.com](http://www.acorneng.com) for most current specifications.

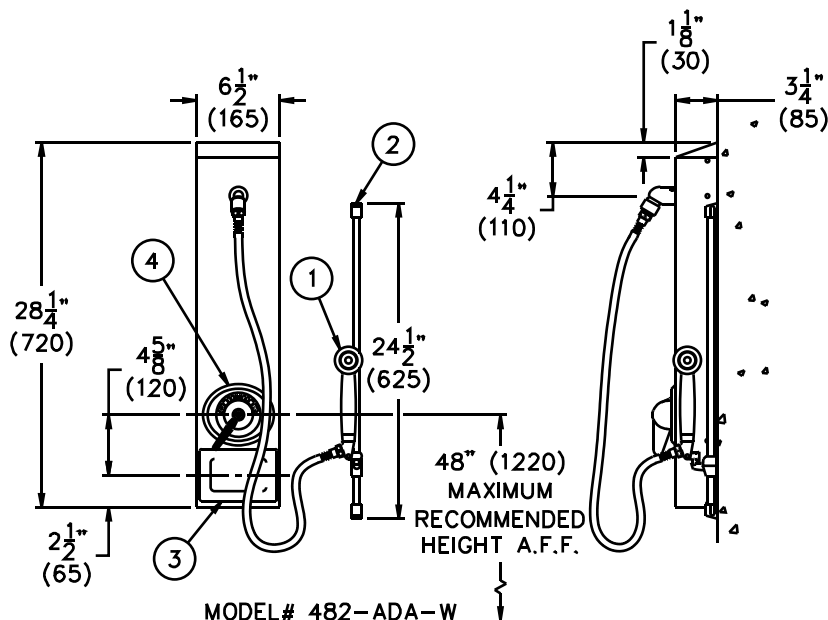

- MODEL# 482-ADA-W
- NOTES:  
 1. Handshower with 60" Hose.  
 2. Glide Rail.  
 3. Recessed Soap Dish.  
 4. Control Valve.

<p><b>Important:</b> Installation instructions and current rough-in are furnished with each fixture. Do not rough in without certified dimensions. Dimensions are subject to manufacturer's tolerance of plus or minus 1/4" and change without notice. Acorn assumes no responsibility for use of void or superseded data. © Copyright 2004 Acorn Engineering Company</p>	
<p>Selection Summary</p> <p>Model No. &amp; Option _____</p> <p>Quantity _____</p>	<p>Approved for Manufacturing</p> <p>Company _____ Title _____</p> <p>Signature _____ Date _____</p>