



Wash-Ware® 3613 Series

Acorn Terrazzo Corner-Lav - 3 Stations - ADA Compliant



3613-ADA-2-SO

Fixture May Show Some Available Options

Please visit www.acorneng.com for most current specifications.

Acorn Terrazzo Corner-Lav - 3 Stations - ADA Compliant

Bowl and Sprayhead are reinforced cast Terrazzo. Bowl is 37" (940 mm.) wide, and has an integral backsplash and sprayhead. Bowl is finished with a clear polyurethane coating. Standard color is Palomino Tan. See available color selection.

Pedestal Housing features molded Terrazzo sides and a heavy gage, stainless steel, front access panel. Pedestal is structurally reinforced.

Barrier-Free Conformance

Units conform with ANSI, UFAS and ADA requirements for accessibility. Compliance is subject to the interpretation and requirements of the local code authority.

Sectional Control is standard. One pushbutton or sensor (specify) actuates one station.

Hand Pushbuttons (suffix option -H) operate individual non-hold open, Air-Controlled metering valves and can be field set for flow ranging from 5 to 60 seconds. Pushbutton requires less than 5 pounds to activate valve.

Electronic Sensor Operation (suffix option -SO) includes individual solenoid valves activated by infrared sensors. A plug-in transformer is provided.

Foot Pushbuttons are not available on this model.

Spray Nozzles are vandal-resistant and provide a concentrated 0.5 GPM spray at each station.

Hot & Cold Supply is blended in a pressure balancing mixing valve furnished with checkstops, strainers and flexible supply connections. A minimum of 30 PSI supply pressure is required.

GUIDE SPECIFICATION

Provide and install an Acorn Three Person Terrazzo Corner-Lav (specify model number and options). Bowl shall be reinforced cast Terrazzo polished and sealed with a clear polyurethane coating and shall have an integral backsplash and sprayhead. Spray nozzles shall be vandal-resistant type with 0.5 GPM flow controls. Provide pressure balancing mixing valve with checkstops and strainers in hot and cold supply and field set water temperature at 105 degrees Fahrenheit. Terrazzo Corner-Lav shall be supplied with mounting angles and bracket for anchoring to the wall as recommended by the manufacturer. Units to conform with ANSI, UFAS and ADA requirements for accessibility.

Wash-Ware®: 3613 Acorn Terrazzo Corner-Lav - 3 Stations - ADA Compliant



MODEL NUMBER AND OPTIONS SELECTION

BASE MODEL NUMBER (Must Specify)

-3613-ADA On-Floor, Terrazzo 3 Station Corner-Lav

FIXTURE MOUNTING AND WASTE (Must Specify)

-2 On-Floor, Wall Outlet

OPERATION (Must Specify)

- H Hand Operation
- PBE Pushbutton Electronic Metering
- SO Sensor Operation

SUPPLY AND VENT

Not applicable to this model.

Product Options

- BAT Battery Operated (-SO)
- JH26 26" Junior Rim Height
- JH28 28" Junior Rim Height
- JH30 30" Junior Rim Height
- JH32 32" Junior Rim Height
- MXT Thermostatic Mixing Valve
- OCT Optional Terrazzo Colors, Specify: _____
- PDM Metering Liquid Soap Dispenser
- ST Single Temperature Supply

Please visit www.acorneng.com for most current specifications.

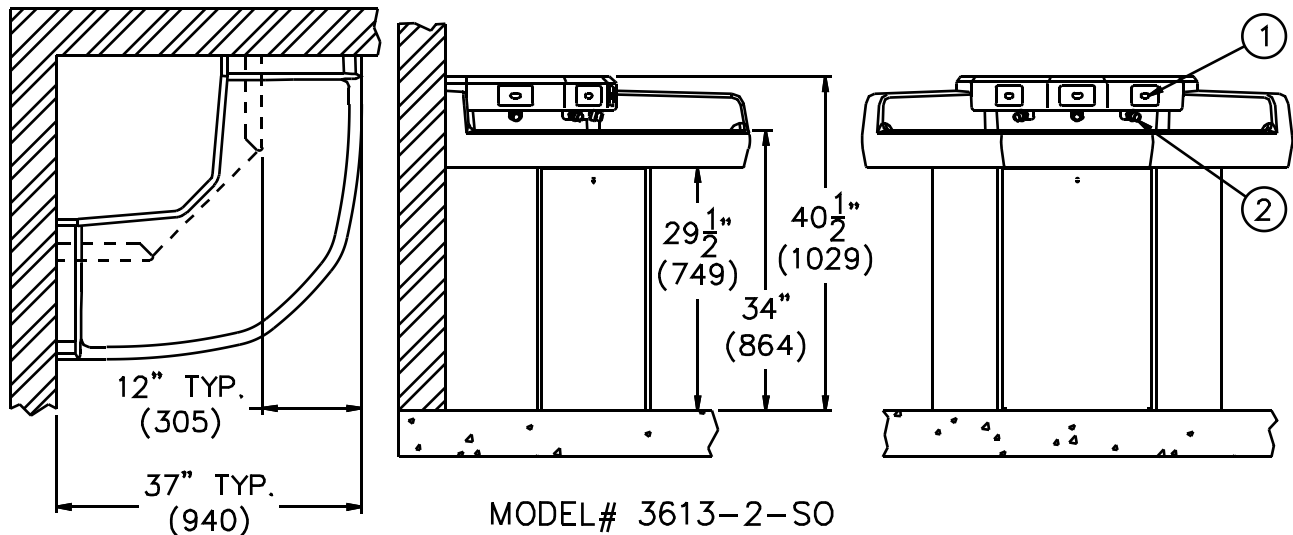

NOTES:

1. -SO Sensor.
2. Spray Nozzle.

<p>Important: Installation instructions and current rough-in are furnished with each fixture. Do not rough in without certified dimensions. Dimensions are subject to manufacturer's tolerance of plus or minus 1/4" and change without notice. Acorn assumes no responsibility for use of void or superseded data. © Copyright 2006 Acorn Engineering Company</p>	
<p style="text-align: center;">Selection Summary</p> <p>Model No. & Option _____</p> <p>Quantity _____</p>	<p style="text-align: center;">Approved for Manufacturing</p> <p>Company _____ Title _____</p> <p>Signature _____ Date _____</p>