



Wash-Ware® 3633 Series

Corterra™ Tri-Lav - 3 Stations - ADA Compliant



3633-2-SO-PDM

Fixture May Show Some Available Options

Please visit www.acorneng.com for most current specifications.

Corterra™ Tri-Lav - 3 Station - ADA Compliant

Bowl, Sprayhead And Pedestal Side Panels are constructed of Corterra™ cast polyester resin (with aluminum trihydrate and other fillers) and conform with ANSI Z124.3 and Z124.6 load ratings. Standard color is Smoky Granite Gray. See available color selections. Bowl is 36" (914mm) wide and includes backsplash and sprayhead. Sprayhead includes access cover and vandal resistant spray nozzles. Bowl includes grid strainer and tailpiece.

Pedestal Housing features Corterra™ side panels and a heavy gage, stainless steel front access panel with vandal-resistant fastener. The standard height 3-Station Corterra™ Tri-Lav Washfountain conforms to all ANSI, UFAS and ADA requirements for reach, clearance and operation. Compliance is subject to the interpretation and requirements of the local code authority.

Sectional Control is standard. One pushbutton or sensor (specify) actuates one station.

Hand Pushbuttons (suffix option -H) operate individual non-hold open, Air-Controlled metering valves and can be field set for flow ranging from 5 to 60 seconds. Pushbutton requires less than 5 pounds to activate valve.

Electronic Sensor Operation (suffix option -SO) includes individual solenoid valves activated by infrared sensors. A plug-in style transformer is provided.

Foot Pushbuttons are not available on this model.

Spray Nozzles are vandal-resistant and provide a concentrated spray of 0.5 GPM at each station.

Hot & Cold Supply is blended in a pressure balancing mixing valve furnished with checkstops, strainers, and flexible supply connections. A minimum of 30 PSI supply pressure is required.

GUIDE SPECIFICATION

Provide and install Corterra™ Tri-Lav Washfountain (specify model number and options). Bowl, sprayhead and pedestal side panels to be constructed of Corterra™ cast polyester resin (with aluminum trihydrate and other fillers) and shall conform to ANSI Z124.3 and Z124.6 (specify color). Unit with 34" standard height rim to conform to ANSI, UFAS and ADA accessibility standards. Provide pressure balancing mixing valve with checkstops and strainers in hot and cold supply and field set water temperature at 105 degrees Fahrenheit. Provide grid strainer and waste tailpiece. Operation (specify): Provide individual solenoid valves activated by infrared sensors with plug-in transformer. Spray nozzles shall be vandal-resistant with 0.5 GPM flow controls.

Wash-Ware®: 3633 Corterra™ Tri-Lav - 3 Stations - ADA Compliant



MODEL NUMBER AND OPTIONS SELECTION

BASE MODEL NUMBER (Must Specify)

-3633 Corterra™ 3-Station Tri-Lav

FIXTURE MOUNTING AND WASTE (Must Specify)

-1 Off-Floor, Wall Outlet

-2 On-Floor, Wall Outlet

OPERATION (Must Specify)

-H Hand Operation

-PBE Pushbutton Electronic Metering

-SO Sensor Operation

SUPPLY AND VENT

Not applicable to this model.

Product Options

-BAT Battery Operated (-SO)

-JH 30" Junior Rim Height

-MXT Thermostatic Mixing Valve

-OCC Optional Corterra™ Colors,
Specify: _____

-PDM Metering Liquid Soap Dispenser

-ST Single Temperature Supply

Please visit www.acorneng.com for most current specifications.

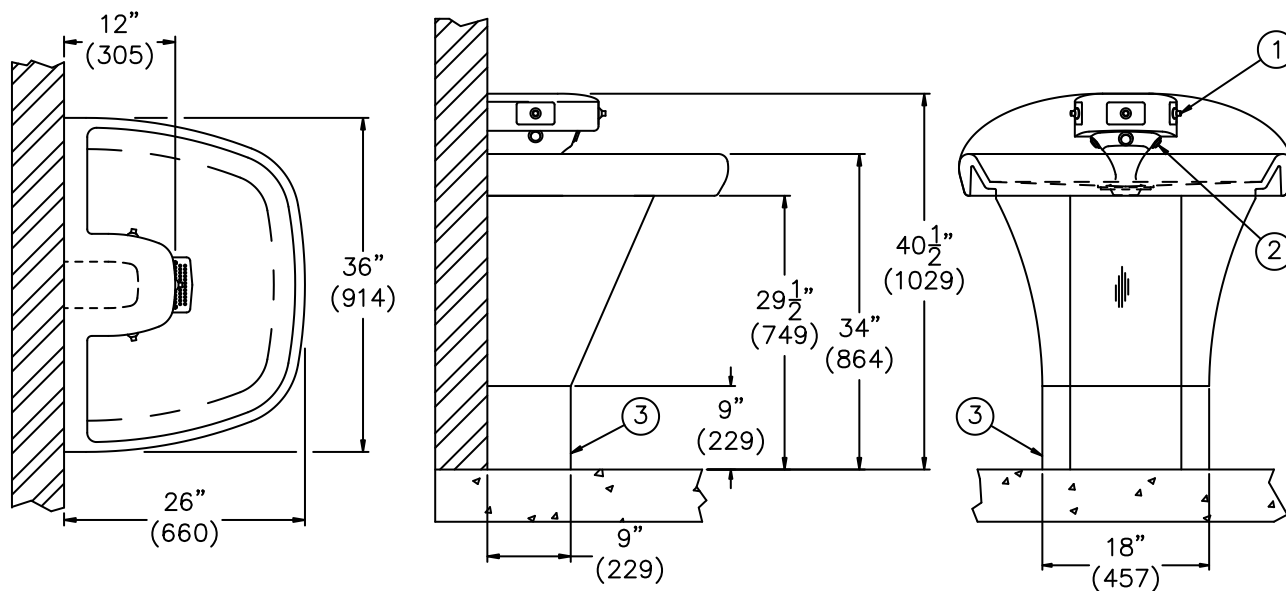

NOTES:

1. -H Pushbutton.
2. Spray Nozzle.

MODEL# 3633-1-H

3. -2 Pedestal.

<p>Important: Installation instructions and current rough-in are furnished with each fixture. Do not rough in without certified dimensions. Dimensions are subject to manufacturer's tolerance of plus or minus 1/4" and change without notice. Acorn assumes no responsibility for use of void or superseded data. © Copyright 2006 Acorn Engineering Company</p>	
<p>Selection Summary</p> <p>Model No. & Option _____</p> <p>Quantity _____</p>	<p>Approved for Manufacturing</p> <p>Company _____ Title _____</p> <p>Signature _____ Date _____</p>