

REFERENCE DRAWINGS	
HARDWARE PACKAGE	9957-900-001
-SW SLEEVE/-MT TEMPLATE (1640-1)	9925-250-001
-SW SLEEVE/-MT TEMPLATE (1640-2)	9925-251-001
-SW SLEEVE/-MT TEMPLATE (1642-1)	9925-252-001
-SW SLEEVE/-MT TEMPLATE (1642-2)	9925-253-001
<b>VALVES:</b>	
-4 AIR-CONTROL (HOT & COLD)	9905-000-003
-3 AIR-CONTROL (SINGLE TEMP.)	9905-001-003
-MVC1 S/T TIME-TROL	9905-201-003
-MVC2 H&C TIME-TROL	9905-200-003
-EVS1 S/T MASTER-TROL	9905-311-002
-EVS2 H&C MASTER-TROL	9905-310-002

CAT. NO.	DIM A	DIM B
1642	24"	22"
1640	21"	19"

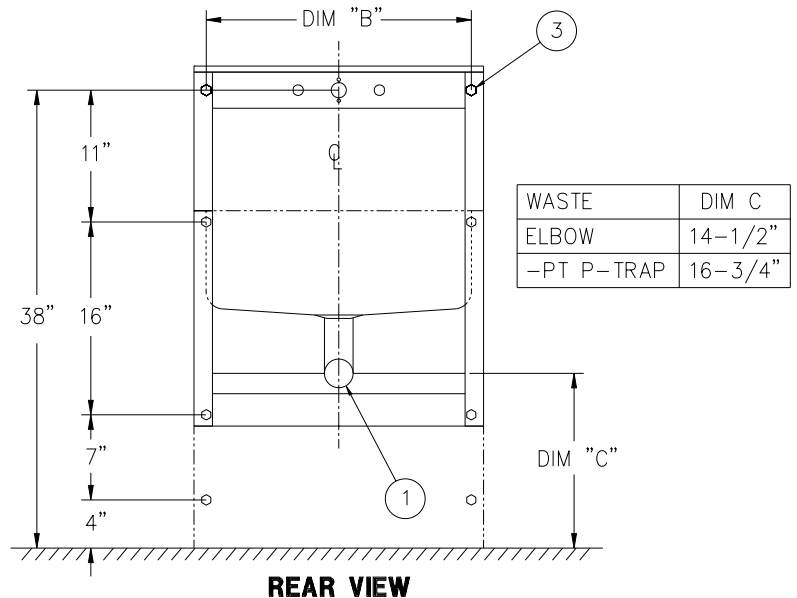
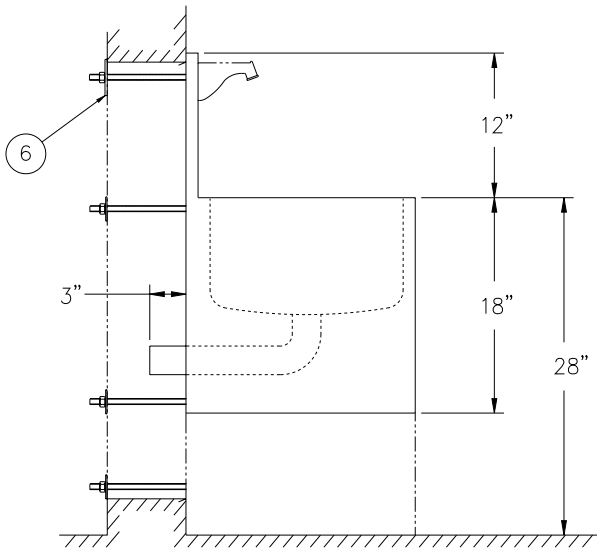

**INSTALLATION INSTRUCTIONS:**

- A-ROUGH-IN FOR FIXTURE WASTE OUTLET ① 2-3/8" O.D. PLAIN END.
- B-SEE REFERENCE DRAWING BOX FOR APPROPRIATE VALVE INSTALLATION DRAWINGS.
- C-THREAD 1/2"-13 UNC STUDS ② INTO MOUNTING POINTS ③ AT REAR OF FIXTURE. STUDS ② MUST HAVE A MINIMUM 1/2" ENGAGEMENT.

- D-LOCATE FIXTURE INTO PLACE, SLIDING STUDS ③ THROUGH SLEEVE OR WALL OPENINGS. NOTE: IT MAY BE NECESSARY TO SUPPORT OFF-FLOOR FIXTURES ON CELL SIDE OF THE WALL TO SECURE PROPERLY FROM PIPE CHASE.
- E-PLACE WASHERS ⑤ (OR PLATE ⑥) AND NUTS ⑦ ONTO STUDS ②. TIGHTEN TO 60 FT/LBS.
- F-MAKE-UP LAVY WASTE CONNECTION.

<p><b>ACORN ENGINEERING COMPANY</b> P.O. BOX 3527 INDUSTRY, CA. 91744 (626) 336-4561 FAX (626) 961-2200</p>	<p>TITLE <b>SERVICE SINK CAT. #1640 &amp; #1642</b></p>		
	<p>MANUFACTURE DATE</p> <p><b>OCT. 1st, 1997</b></p> <p><b>TO PRESENT</b></p>	<p>DATE ISSUED</p> <p><b>09-04-97</b></p> <p>DATE REVISED</p> <p><b>03-18-99</b></p>	<p>DRAWING NUMBER</p> <p><b>9925-350-002</b></p>

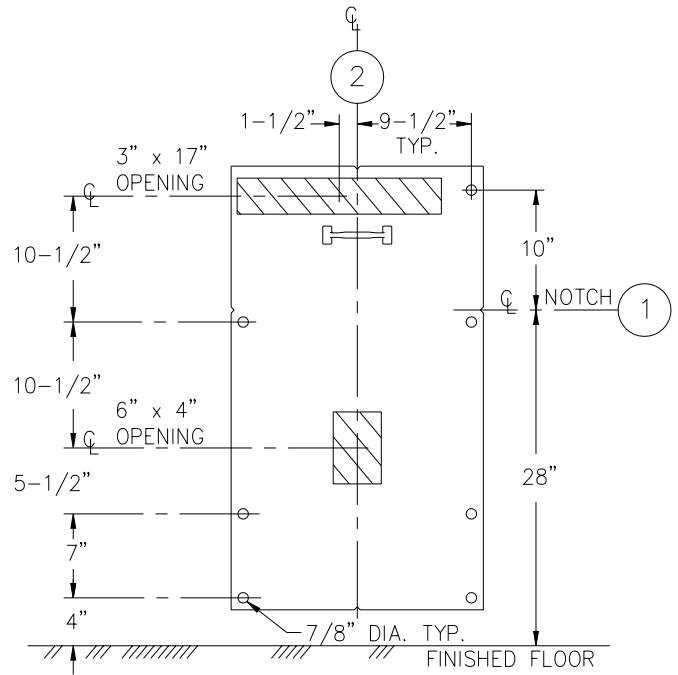
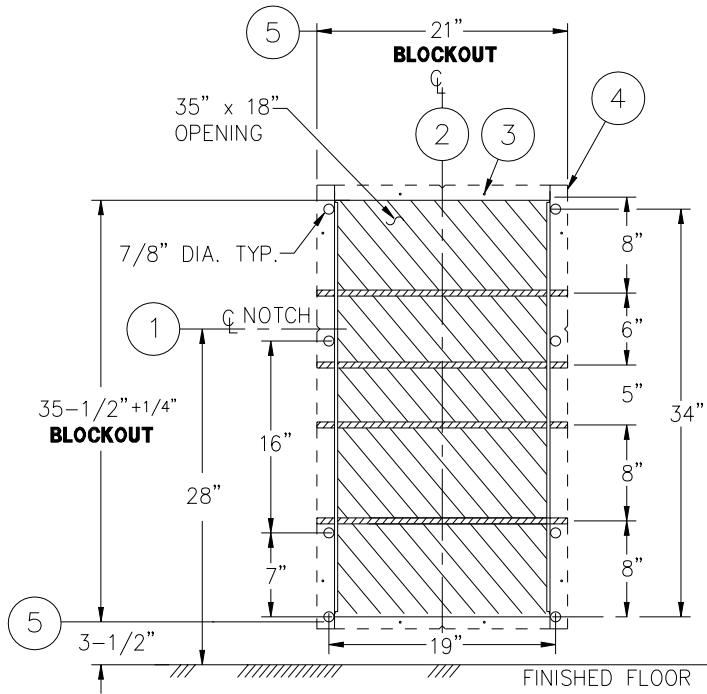

**WALL SLEEVE (-SW) BOTH VIEWS ARE FROM CELL SIDE METAL TEMPLATE (-MT)**

RIGHT HAND FIXTURE ROUGH-INS SHOWN, LEFT HAND FIXTURE OPPOSITE



SHADED AREAS ARE REQUIRED WALL OPENINGS

**WALL SLEEVE**

SLEEVES ARE INSTALLED IN FORMS (USING NAIL HOLES ③ PROVIDED) OR GROUTED INTO BLOCK WALLS, BECOMING A PERMANENT PART OF WALL.

- A. INSTALL SLEEVE WITH FLANGE ④ ON CHASE SIDE OF WALL.
- B. LOCATE TOP AND BOTTOM NOTCHES AT VERTICAL CENTERLINE ② OF PLUMBING FIXTURE.
- C. LOCATE SIDE NOTCHES ① AT DIMENSION SHOWN, MEASURED FROM THE FINISHED FLOOR ON CELL (FIXTURE) SIDE.

**NOTES:**

- 1. FOR POURED WALL CONSTRUCTION, TEMPORARY BRACING SHOULD BE INSTALLED WITHIN SLEEVE OPENING TO PREVENT DEFORMATION TO SLEEVE WHICH MAY OCCUR DURING POUR. DO NOT POUR CONCRETE DIRECTLY ON TOP OF WALL SLEEVE.
- 2. WHEN SLEEVES ARE NOT AVAILABLE BLOCKOUT FOR SLEEVE OPENING IN WALL PER DIMENSIONS SHOWN ⑤.

**METAL TEMPLATES (-MT)**

TEMPLATES ARE USED TO LAYOUT REQUIRED WALL OPENINGS FOR SUBSEQUENT FLAME CUTTING OR CORE DRILLING.

- A. STRIKE A HORIZONTAL CHALKLINE ① ON THE WALL AT DIMENSION SHOWN, MEASURED FROM THE FINISHED FLOOR ON CELL (FIXTURE) SIDE. THIS WILL LOCATE CENTERLINE FOR HORIZONTAL NOTCHES ON TEMPLATE.
- B. STRIKE A VERTICAL CHALKLINE ② ON THE WALL TO INDICATE CENTERLINE OF FIXTURE. THIS WILL LOCATE CENTERLINE FOR VERTICAL NOTCHES ON TEMPLATE.
- C. PLACE TEMPLATE AGAINST WALL. LOCATE NOTCHES ALONG CHALKLINES. MARK WALL FOR REQUIRED OPENING.

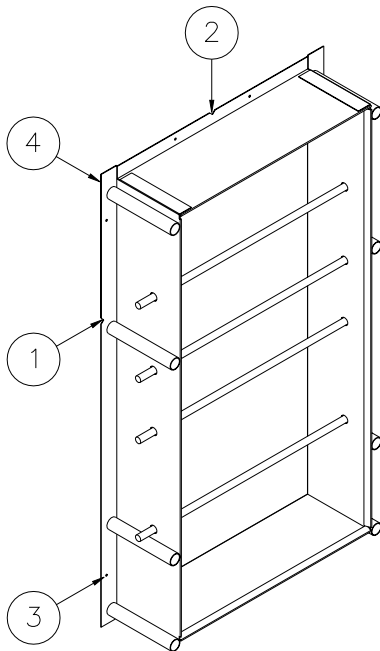

**WALL SLEEVE (-SW)**



**ACORN ENGINEERING COMPANY**  
P.O. BOX 3527 INDUSTRY, CA. 91744  
(626) 336-4561 FAX (626) 961-2200

TITLE <b>-SW WALL SLEEVE AND -MT METAL TEMPLATE - CAT. #1640-2</b>		
MANUFACTURE DATE	DATE ISSUED	DRAWING NUMBER
<b>MAY 1982</b>	<b>3-1-90</b>	<b>9925-251-001</b>
<b>TO PRESENT</b>	DATE REVISED	
	<b>6/22/98</b>	