

WASTE OUTLET	DIM "A"
STANDARD	10-1/4"
-PT OPTION	6-3/4"

REFERENCE DRAWINGS	
HARDWARE PACKAGE	9957-900-001
-SW SLEEVE / -MT TEMPLATE	9925-211-001
VALVES:	
-4 AIR-CONTROL (HOT & COLD)	9905-000-003
-3 AIR-CONTROL (SINGLE TEMP.)	9905-001-003
-MVC1 S/T TIME-TROL	9905-201-003
-MVC2 H&C TIME-TROL	9905-200-003
-EVS1 S/T MASTER-TROL	9905-311-002
-EVS2 H&C MASTER-TROL	9905-310-002

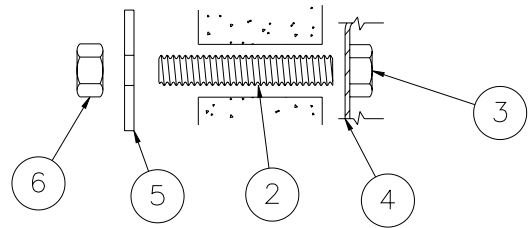

MOUNTING DETAIL

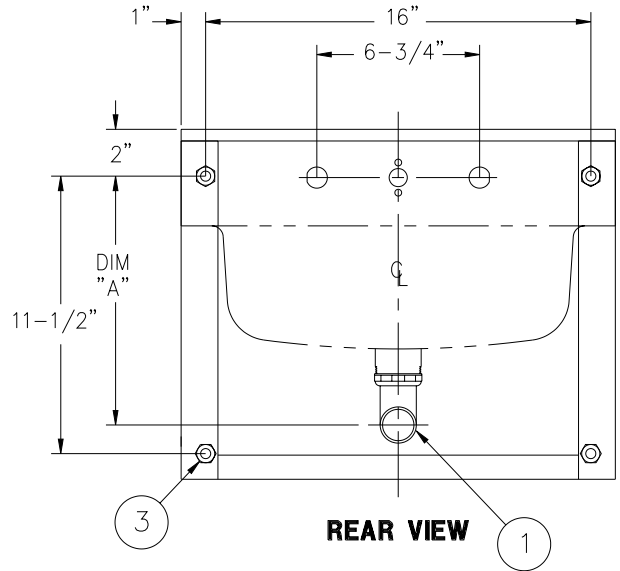
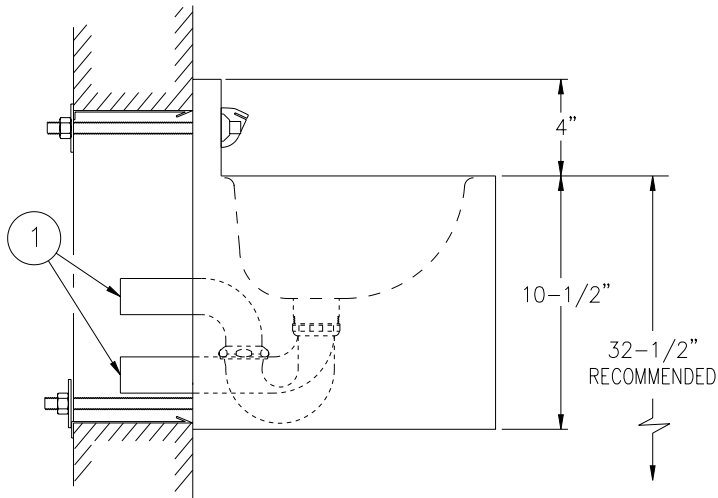

REAR VIEW

INSTALLATION INSTRUCTIONS:

- A-ROUGH-IN FOR FIXTURE WASTE OUTLET (1):
• 1-1/2" O.D. PLAIN END PROVIDED STANDARD & FOR -PT.
- B-SEE REFERENCE DRAWING BOX FOR APPROPRIATE VALVE INSTALLATION DRAWINGS.
- C-THREAD 1/2"-13 UNC STUDS (2) INTO MOUNTING POINTS (3) AT REAR OF FIXTURE. STUDS (2) MUST HAVE A MINIMUM 1/2" ENGAGEMENT.

- D-PLACE LAVATORY (4) UP AGAINST THE WALL, SLIDING STUDS (2) THROUGH SLEEVE OR WALL OPENINGS.
- E-PLACE WASHERS (5) (OR PLATE) AND NUTS (6) ONTO STUDS (2). TIGHTEN TO 60 FT/LBS.
- F-MAKE-UP LAVY WASTE CONNECTION - 1-1/2" O.D. PLAIN END (SUITABLE FOR A COMPRESSION CONNECTION).

ACORN ENGINEERING COMPANY P.O. BOX 3527 INDUSTRY, CA. 91744 (626) 336-4561 FAX (626) 961-2200	TITLE 18" RECTANGULAR LAVY CAT. #1655	
	MANUFACTURE DATE APRIL 30, 1998 TO PRESENT	DATE ISSUED 3/31/98 DATE REVISED 03/12/02

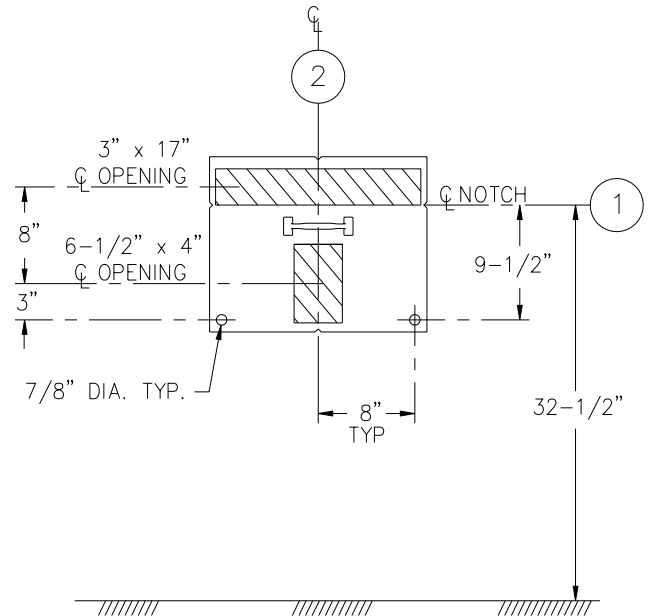
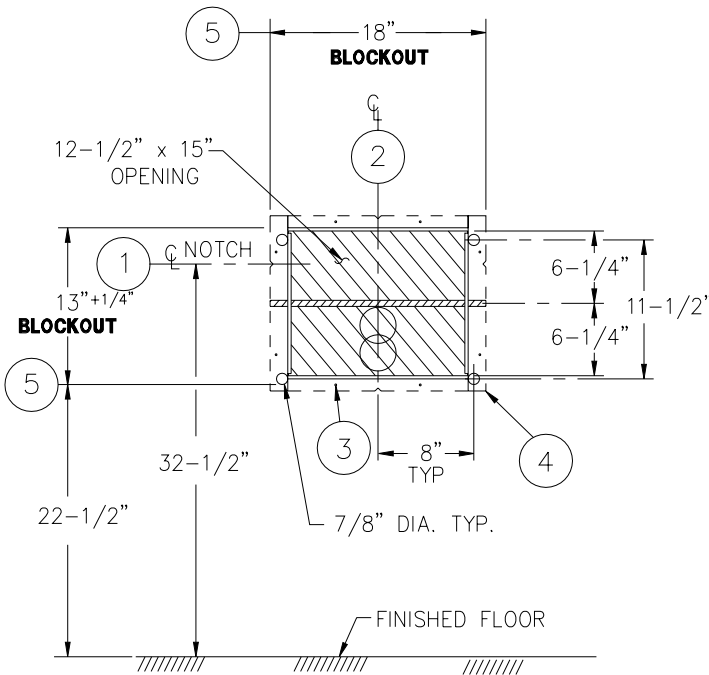

WALL SLEEVE (-SW) BOTH VIEWS ARE FROM CELL SIDE METAL TEMPLATE (-MT)

RIGHT HAND FIXTURE ROUGH-INS SHOWN, LEFT HAND FIXTURE OPPOSITE

SHADED AREAS ARE REQUIRED WALL OPENINGS

WALL SLEEVE

SLEEVES ARE INSTALLED IN FORMS (USING NAIL HOLES (3) PROVIDED) OR GROUTED INTO BLOCK WALLS, BECOMING A PERMANENT PART OF WALL.

- A. INSTALL SLEEVE WITH FLANGE (4) ON CHASE SIDE OF WALL.
- B. LOCATE TOP AND BOTTOM NOTCHES AT VERTICAL CENTERLINE (2) OF PLUMBING FIXTURE.
- C. LOCATE SIDE NOTCHES (1) AT DIMENSION SHOWN, MEASURED FROM THE FINISHED FLOOR ON CELL (FIXTURE) SIDE.

NOTES:

- 1. FOR POURED WALL CONSTRUCTION, TEMPORARY BRACING SHOULD BE INSTALLED WITHIN SLEEVE OPENING TO PREVENT DEFORMATION TO SLEEVE WHICH MAY OCCUR DURING POUR. DO NOT POUR CONCRETE DIRECTLY ON TOP OF WALL SLEEVE.
- 2. WHEN SLEEVES ARE NOT AVAILABLE BLOCKOUT FOR SLEEVE OPENING IN WALL PER DIMENSIONS SHOWN (5).

METAL TEMPLATES (-MT)

TEMPLATES ARE USED TO LAYOUT REQUIRED WALL OPENINGS FOR SUBSEQUENT FLAME CUTTING OR CORE DRILLING.

- A. STRIKE A HORIZONTAL CHALKLINE (1) ON THE WALL AT DIMENSION SHOWN, MEASURED FROM THE FINISHED FLOOR ON CELL (FIXTURE) SIDE. THIS WILL LOCATE CENTERLINE FOR HORIZONTAL NOTCHES ON TEMPLATE.
- B. STRIKE A VERTICAL CHALKLINE (2) ON THE WALL TO INDICATE CENTERLINE OF FIXTURE. THIS WILL LOCATE CENTERLINE FOR VERTICAL NOTCHES ON TEMPLATE.
- C. PLACE TEMPLATE AGAINST WALL. LOCATE NOTCHES ALONG CHALKLINES. MARK WALL FOR REQUIRED OPENING.

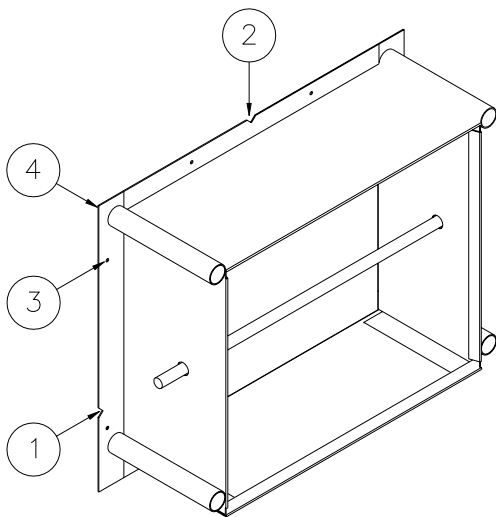

WALL SLEEVE (-SW)



ACORN ENGINEERING COMPANY
P.O. BOX 3527 INDUSTRY, CA. 91744
(626) 336-4561 FAX (626) 961-2200

TITLE **-SW SLEEVE, -MT TEMPLATE - CAT. #1655\1655-VAC, 1657\1657-VAC & 1658**

MANUFACTURE DATE JUNE 1971 TO PRESENT	DATE ISSUED 3-1-90	DRAWING NUMBER 9925-211-001
	DATE REVISED 6/22/98	



DIMENSION "A"	
UP TO 8" WALL	8" TO 12" WALL
15-1/8"	19-1/8"

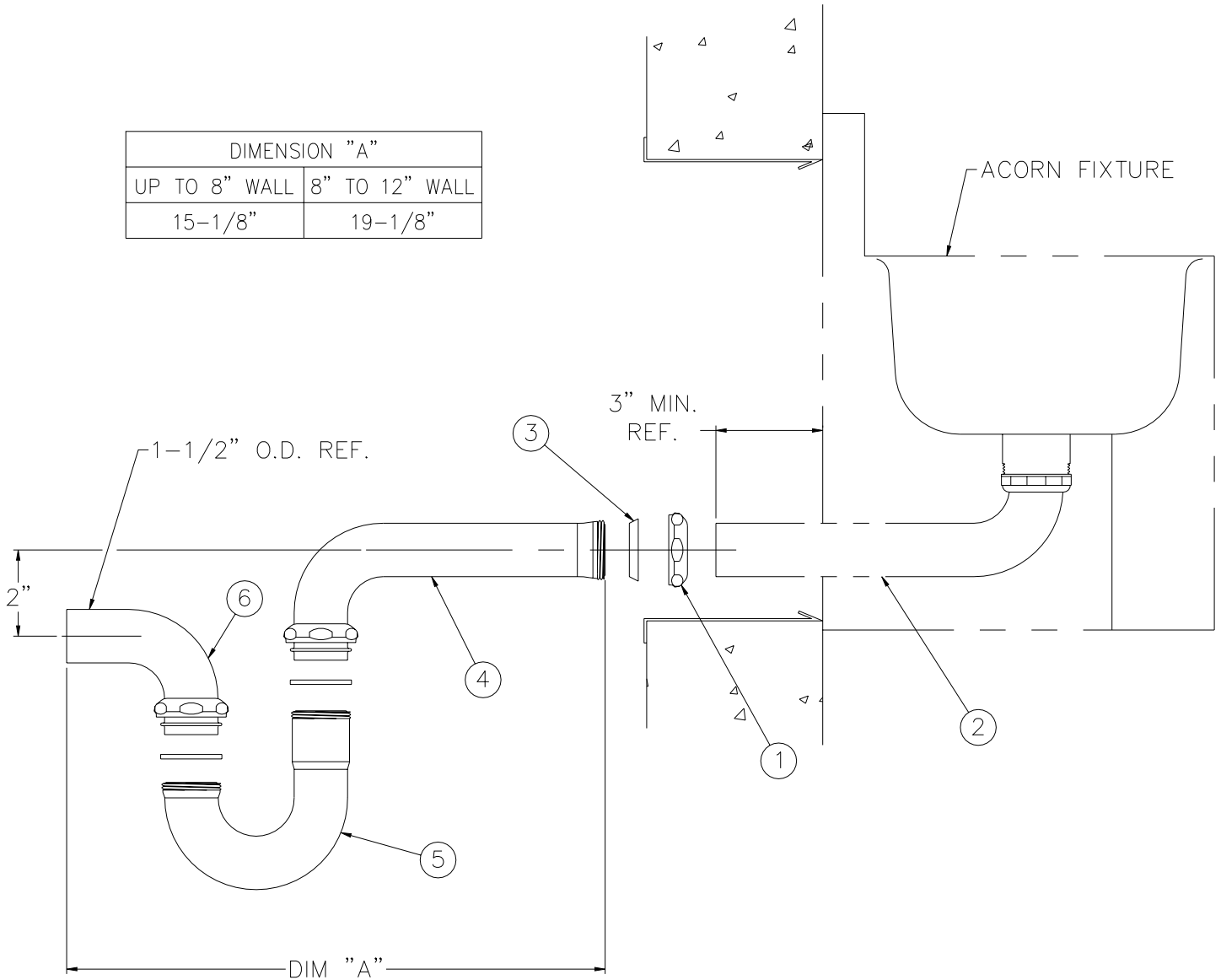

INSTALLATION INSTRUCTIONS:

A- AFTER INSTALLING ACORN UNIT ON FINISHED WALL, SLIP COMPRESSION NUT ① OVER 1-1/2" O.D. PLAIN END WASTE ②. USING COMPRESSION GASKET ③, AND NUT ① MAKE-UP COMPRESSION CONNECTION WITH SLIP JOINT ELBOW ④.

B- REMOVABLE TUBULAR P-TRAP ⑤ CONNECTS TO SLIP JOINT ELBOW ④ AND PLAIN END ELBOW ⑥ WITH COMPRESSION CONNECTIONS AS SHOWN.

NOTE: TUBULAR P-TRAP IS REMOVABLE IN ORDER TO ALLOW FOR WASTE CLEANOUT.

<p>ACORN ENGINEERING COMPANY P.O. BOX 3527 INDUSTRY, CA. 91744 (626) 336-4561 FAX (626) 961-2200</p>	<p>TITLE LAVATORY THRU-WALL WASTE CONNECTION w/ P-TRAP & CLEANOUT CAT. # -LW1</p>	
	<p>MANUFACTURE DATE APRIL 30, 1998 TO PRESENT</p>	<p>DATE ISSUED 3/19/98</p> <p>DATE REVISED 4/23/98</p>