

REFERENCE DRAWING	
FLUSH VALVE ACCESS PANEL MODEL NO. 2898	9908-399-001
WALL SLEEVE -W	5055-590-001
TEMPLATE -W	5010-590-001
WALL SLEEVE -T	5055-595-001
TEMPLATE -T	5010-595-001

**INSTALLATION INSTRUCTIONS**

- A- ROUGH-IN FOR FLUSHING INLET 3/4" NPT ① & WASTE OUTLET 2" NPT ③ .
- B- IF AN OPTIONAL 2898 FLUSH VALVE ACCESS PANEL ② IS REQUIRED (FOR BACK SUPPLY FLUSH VALVES), INSTALL SLEEVE. SEE DRAWING #9908-399-001.
- C- MOUNT URINAL TO WALL BY THREADING 1/2"-13 UNC STUDS ④ INTO MOUNTING POINTS ⑤ AT REAR OF FIXTURE ⑥ . STUDS ④ MUST HAVE A MINIMUM 1/2" ENGAGEMENT.
- D- PLACE URINAL ⑥ UP AGAINST THE WALL, SLIDING STUDS ④ THROUGH OPTIONAL -SW WALL SLEEVE OR WALL OPENINGS.
- E- PLACE WASHER ⑦ AND NUTS ⑧ ONTO STUDS ④ TIGHTEN TO 60 FT/LBS.
- F- MAKE-UP URINAL WASTE CONNECTION.
- G- CONNECT FLUSH VALVE ⑨ PER MANUFACTURERS' RECOMMENDATIONS.

FOR -ADA MODELS
1- FLUSH VALVE MUST BE HYDRAULICALLY ACTUATED OR SUPPLIED WITH A SPECIAL HANDLE. MAXIMUM CONTROL HEIGHT IS 44" ABOVE FINISHED FLOOR.
2- 20" RIM HEIGHT BECOMES 17" MAXIMUM ALL VERTICAL DIMENSIONS CHANGE ACCORDINGLY.
3- REFER TO A.D.A. ACCESSIBILITY GUIDELINES FOR COMPLETE INSTALLATION REQUIREMENTS.

<p><b>ACORN ENGINEERING COMPANY</b> P.O. BOX 3527 INDUSTRY, CA. 91744 (626) 336-4561 FAX (626) 961-2200</p>	<p>TITLE <b>STALL TYPE WASHOUT URINAL (CAT. # 1720) (CAT. #1720-ADA)</b></p>		
	<p>MANUFACTURE DATE</p>	<p>DATE ISSUED <b>03/28/01</b></p> <p>DATE REVISED</p>	<p>DRAWING NUMBER <b>9925-077-001</b></p>



**BOTH VIEWS ARE FROM CELL SIDE**

SHADED AREAS ARE REQUIRED WALL OPENINGS

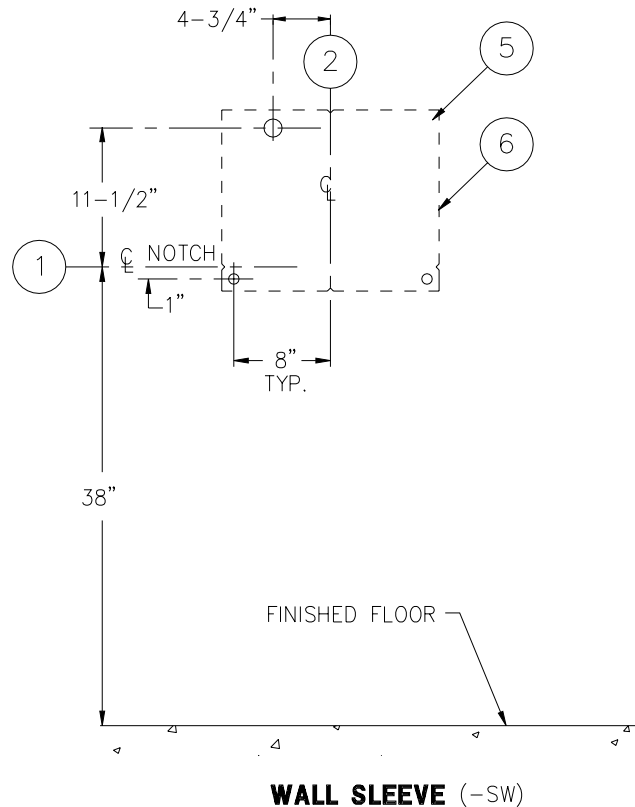
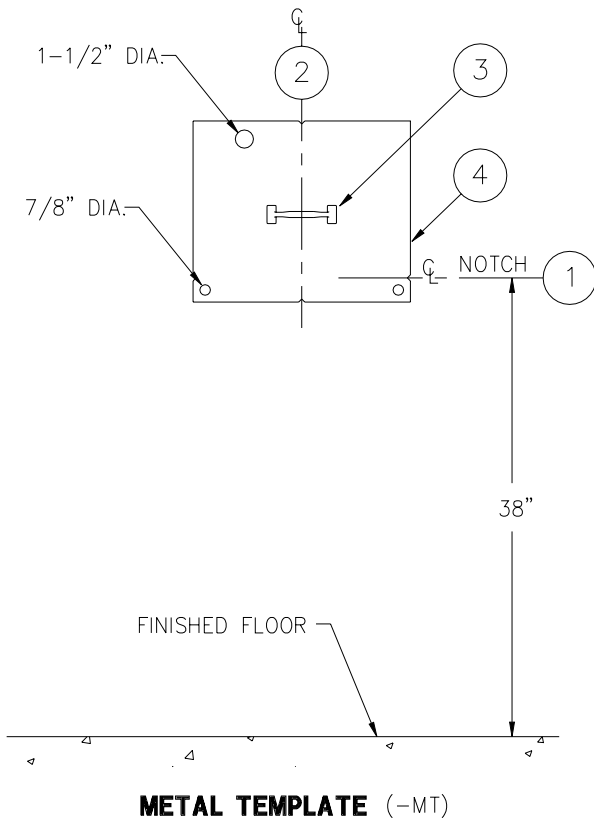

**INSTALLATION INSTRUCTIONS**

**METAL TEMPLATES (-MT)**

TEMPLATES ARE USED TO LAYOUT REQUIRED WALL OPENINGS FOR SUBSEQUENT FLAME CUTTING OR CORE DRILLING.

- A- STRIKE A HORIZONTAL CHALKLINE (1) ON THE WALL 38" ABOVE FINISHED FLOOR. THIS WILL LOCATE CENTERLINE FOR HORIZONTAL NOTCHES ON TEMPLATE.
- B- STRIKE A VERTICAL CHALKLINE (2) ON THE WALL TO INDICATE CENTERLINE OF FIXTURE. THIS WILL LOCATE FOR VERTICAL NOTCHES ON TEMPLATE.
- C- USING HANDLE (3) ON TEMPLATE (4), PLACE TEMPLATE AGAINST THE WALL, LOCATING NOTCHES AT CHALKLINES. MARK FOR WALL OPENINGS.

**WALL SLEEVES (-SW)**

SLEEVES ARE INSTALLED IN FORMS (USING NAIL HOLES (5) PROVIDED) OR GROUTED INTO BLOCK WALLS, BECOMING A PERMANENT PART OF THE WALL.

**NOTE:** FOR POURED WALL CONSTRUCTION, TEMPORARY BRACING SHOULD BE INSTALLED WITHIN SLEEVE OPENING TO PREVENT DEFORMATION TO SLEEVE WHICH MAY OCCUR DURING POUR. DO NOT POUR CONCRETE DIRECTLY ON TOP OF WALL SLEEVE.

- A- INSTALL SLEEVE WITH FLANGE (6) ON CHASE SIDE OF WALL.
- B- TOP AND BOTTOM NOTCHES TO BE LOCATED AT VERTICAL CENTERLINE (2) OF SLEEVE.
- C- SIDE NOTCHES (1) TO BE LOCATED AT 38" ABOVE THE FINISHED CELL SIDE FLOOR (TOP OF URINAL HEIGHT).



**ACORN ENGINEERING COMPANY**  
P.O. BOX 3527 INDUSTRY, CA. 91744  
(626) 336-4561 FAX (626) 961-2200

TITLE <b>SLEEVES AND TEMPLATES (CAT. #1720-T)</b>		
MANUFACTURE DATE <b>FEB 1975</b> <b>TO PRESENT</b>	DATE ISSUED <b>3-1-90</b>	DRAWING NUMBER <b>9925-247-001</b>
	DATE REVISED <b>08/05/00</b>	