

INSTALLATION INSTRUCTIONS:

- A- PRIOR TO INSTALLATION OF PUSHBUTTON PANEL (1), MOUNT PUSHBUTTON (2), ESCUTCHEON (3) AND THE ESCUTCHEON RETAINER (4) TO THE PANEL. HAND TIGHTEN (2) MOUNTING STUDS (6) INTO NUTS (20) ON BACK OF VALVE PANEL (1). THREAD PUSHROD SLEEVE ASSY. (5) INTO RETAINER NUT (4).
- B- HAND TIGHTEN (4) MOUNTING STUDS (6) INTO BACK OF FLANGED SHOWER HEAD (9). INSTALL 1/4" RISER TUBING (13). HOLD SHOWER HEAD AGAINST WALL. FROM CHASE SIDE, PLACE BACK PLATE (7) OVER STUDS (6). SCREW NUTS & WASHERS (8) ONTO EACH STUD. TIGHTEN AGAINST BACK PLATE (7).
- C- HOLD VALVE PANEL (1) AGAINST WALL. FROM CHASE SIDE, PLACE VALVE SUPPORT PLATE (17) OVER STUDS; ATTACH WITH NUTS & WASHERS (8). NOTE: DO NOT EXCEED 6.5 FT/LBS MAXIMUM TORQUE ON MOUNTING NUTS (8). PLACE CONDUIT NUT (18) ON PUSHROD SLEEVE (5) AND TIGHTEN.
- D- MOUNT SOLENOID VALVE ASSEMBLY (11) AS REQUIRED WITHIN 10 FEET OF THE FIXTURE. WALL FASTENER BY OTHERS.
- E- MOUNT VALVE CONTROLLER (14) AS REQUIRED WITHIN 100 FEET OF THE PUSHBUTTON. CONNECT 1/8" O.D. POLYETHYLENE AIR LINE (12) FROM PUSHBUTTON (2) TO CONTROLLER (14) POSITION MARKED "ACTUATOR". HAND TIGHTEN THE FERRULE NUT AT PUSHBUTTON. SEE DETAIL "A".
- F- TO ADJUST PUSHBUTTON ASSEMBLY. LOOSEN THE LOCKNUT (10) AND ROTATE THE ADJUSTING SLEEVE (19) AS REQUIRED. WHEN PROPERLY ADJUSTED THERE WILL BE NO PLAY AND ONLY MINOR TENSION AT THE BOTTOM.

REFERENCE DRAWINGS			
ASSEMBLIES	NUMBERS	ELECTRICAL COMPONENTS	
VALVE BODY	9955-006-003	VALVE CONTROLLER	9955-025-001
-D SOAP DISH	9925-130-001	SOLENOID VALVE	9955-020-002
STOP	9956-040-003	TRANSFORMER	9955-020-002
SHOWER HEAD	9970-002-004	WIRING COMPONENTS	9955-020-002
MOUNTING HDWR.	9957-900-001		
-SW SLEEVE/-MT TEMPLATE	9925-261-001		

NOTE:

MAXIMUM RECOMMENDED WORKING PRESSURE IS 100 PSI; TEMPERATURE IS 130°F; OUTLET TEMPERATURE IS RECOMMENDED AT A MAXIMUM OF 105°F. TRANSFORMER MUST BE WIRED TO A GFI PROTECTED CIRCUIT, FIXTURE MUST BE EARTH GROUND PER N.E.C. (NATIONAL ELECTRIC CODE).

WARNING:

PRIOR TO MAKING INSTALLATION, SUPPLY LINES MUST BE FLUSHED OF ALL FOREIGN MATERIAL SUCH AS PIPE DOPE, CHIPS, ETC. VALVE MUST BE DRAINED PRIOR TO BEING SUBJECTED TO FREEZING TEMPERATURES. MAXIMUM RECOMMENDED OUTLET WATER TEMPERATURE IS 105°F.

- G- CONNECT WIRES (15) (MARKED "VALVE") FROM CONTROLLER TO WIRES (16) FROM SOLENOID VALVE (21). ASSEMBLE USING THE WIRE CONNECTORS PROVIDED. EXTENSION WIRE MAY BE INCLUDED - IF ORDERED.
- H- CONNECT RISER TUBING (13) TO VALVE (11).
- I- CONNECT WIRES (22) FROM TRANSFORMER (24VAC) (23) TO VALVE CONTROLLER (14). ASSEMBLE USING WIRE CONNECTORS PROVIDED. EXTENSION WIRES FROM TRANSFORMER MAY BE INCLUDED - IF ORDERED.
- J- AFTER THOROUGHLY FLUSHING THE SUPPLY LINES, MAKE-UP SUPPLY CONNECTIONS (1/2" NPS FEMALE). THREAD FLEX CONNECTOR HOSE (24) FROM VALVE INLET TO SUPPLY STUBOUTS. (NOTE: SUPPLY INLET CONNECTION WILL ACCOMMODATE 1/2" NPT MALE ADAPTER.)
- K- SET TIMING ON THE VALVE CONTROLLER (14) AT DESIRED SETTING FOR FLOW DURATION.

<p>ACORN ENGINEERING COMPANY P.O. BOX 3527 INDUSTRY, CA. 91744 (626) 336-4561 FAX (626) 961-2200</p>	<p>TITLE PENAL WALL SHOWERS - SINGLE TEMP. - CAT. #1743-MVC1</p>		
	<p>MANUFACTURE DATE</p> <p>SEPTEMBER 1995</p> <p>TO PRESENT</p>	<p>DATE ISSUED</p> <p>04/05/01</p>	<p>DRAWING NUMBER</p> <p>9905-218-001</p>
		<p>DATE REVISED</p> <p>01/19/04</p>	



BOTH VIEWS ARE FROM CELL SIDE

SHADED AREAS ARE REQUIRED WALL OPENINGS

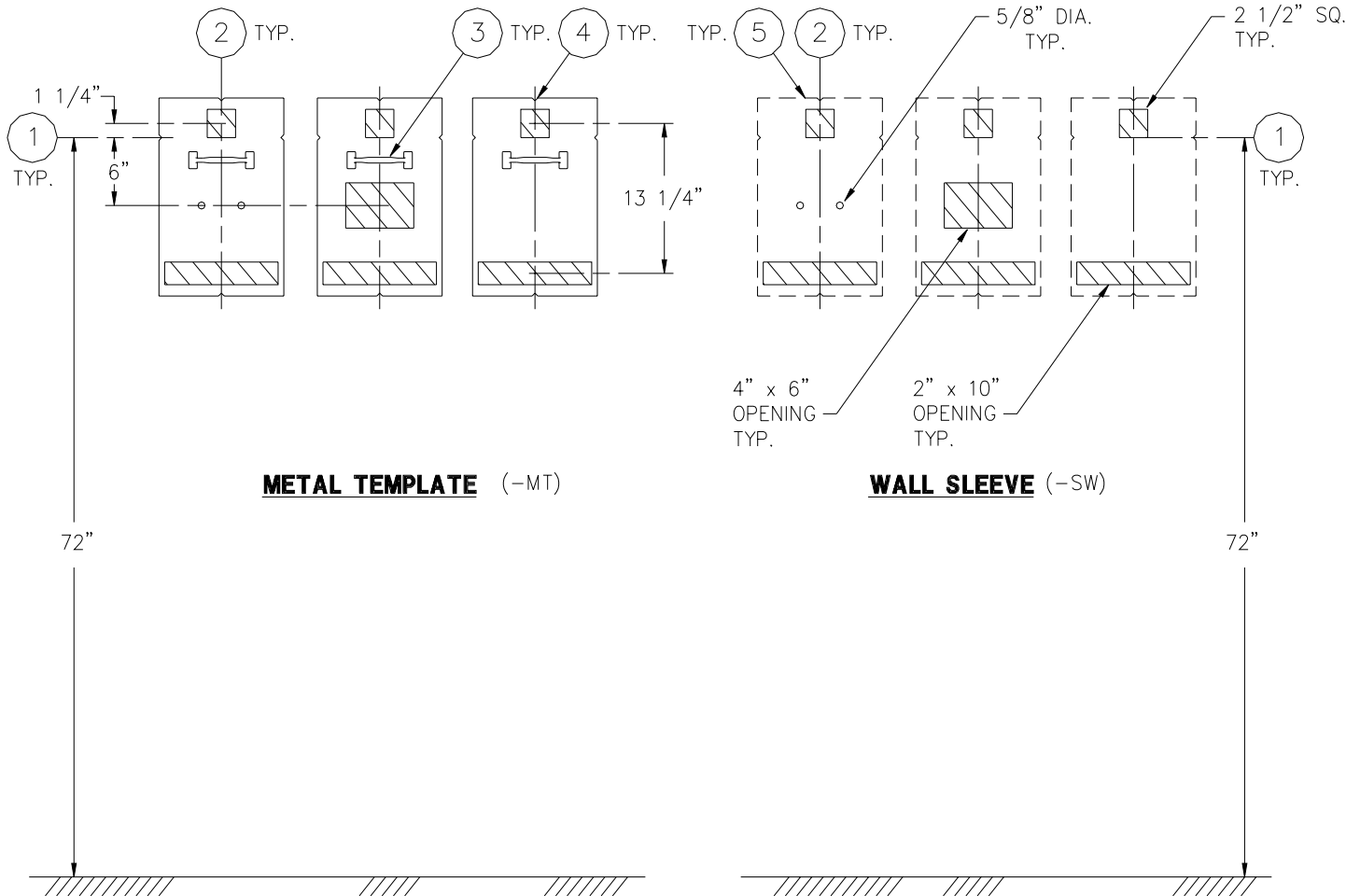

METAL TEMPLATE (-MT)

WALL SLEEVE (-SW)

INSTALLATION INSTRUCTIONS

METAL TEMPLATES (-MT)

TEMPLATES ARE USED TO LAYOUT REQUIRED WALL OPENINGS FOR SUBSEQUENT FLAME CUTTING OR CORE DRILLING.

- A- STRIKE A HORIZONTAL CHALKLINE ① ON THE WALL 72" ABOVE FINISHED FLOOR. THIS WILL LOCATE CENTERLINE FOR HORIZONTAL NOTCHES ON TEMPLATE.
- B- STRIKE A VERTICAL CHALKLINE ② ON THE WALL TO INDICATE CENTERLINE OF FIXTURE. THIS WILL LOCATE FOR VERTICAL NOTCHES ON TEMPLATE.
- C- USING HANDLE ③ ON TEMPLATE ④, PLACE TEMPLATE AGAINST THE WALL, LOCATING NOTCHES AT CHALKLINES. MARK FOR WALL OPENINGS.

WALL SLEEVES (-SW)

SLEEVES ARE NAILED (OR SCREWED) INTO FORMS OR GROUTED INTO BLOCK WALLS, BECOMING A PERMANENT PART OF THE WALL.

NOTE: FOR POURED WALL CONSTRUCTION, TEMPORARY BRACING SHOULD BE INSTALLED WITHIN SLEEVE OPENING TO PREVENT DEFORMATION TO SLEEVE WHICH MAY OCCUR DURING POUR. DO NOT POUR CONCRETE DIRECTLY ON TOP OF WALL SLEEVE.

- A- INSTALL SLEEVE WITH FLANGE ⑤ ON CHASE SIDE OF WALL.
- B- TOP AND BOTTOM NOTCHES TO BE LOCATED AT VERTICAL CENTERLINE ② OF SLEEVE.
- C- SIDE NOTCHES ① TO BE LOCATED AT 72" ABOVE THE FINISHED CELL SIDE FLOOR (SHOWER HEAD DISCHARGE HEIGHT).



ACORN ENGINEERING COMPANY
P.O. BOX 3527 INDUSTRY, CA. 91744
(626) 336-4561 FAX (626) 961-2200

TITLE

SLEEVES AND TEMPLATES (CAT. #1743, #1743-RD & #1743-D)

MANUFACTURE DATE

**MAY 1975
TO PRESENT**

DATE ISSUED

3-1-90

DATE REVISED

1/30/96

DRAWING NUMBER

9925-261-001