

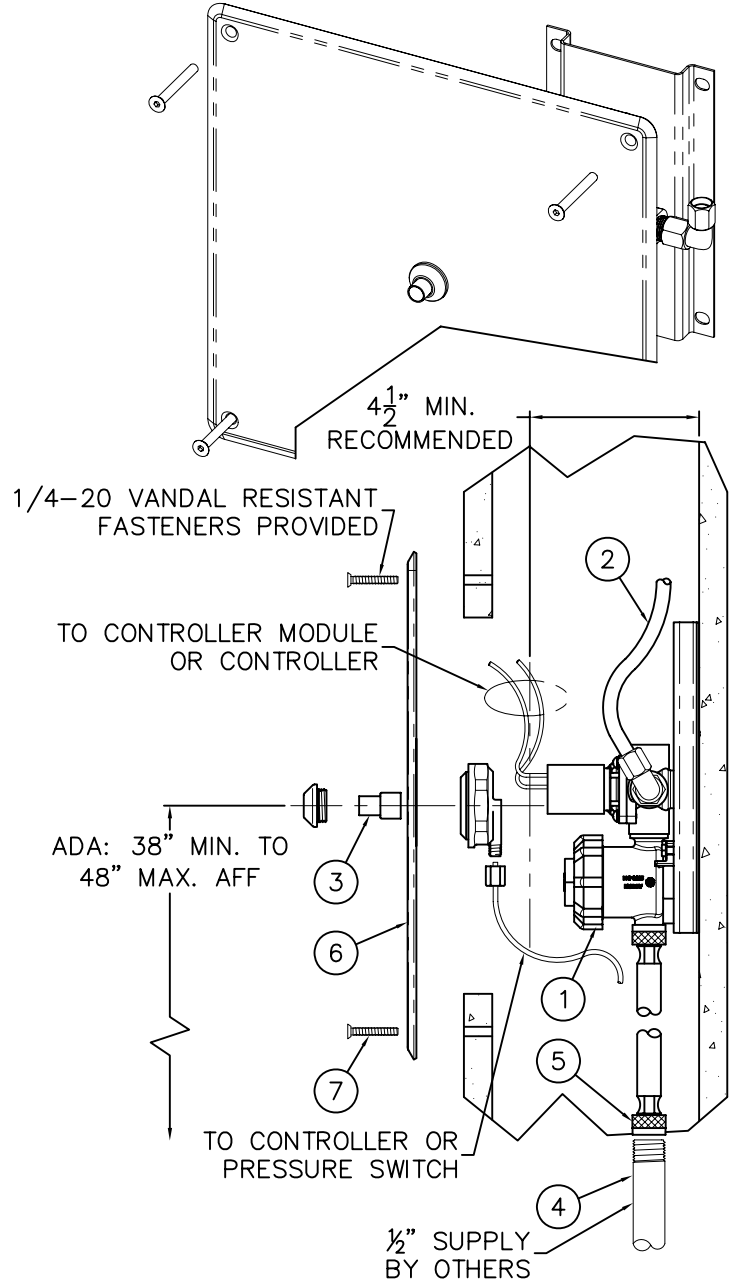

**REFERENCE DRAWINGS**

AIR-CONTROL CONNECT	9900-006-003
MVC VALVE INSTALL	9900-001-004
EVS VALVE INSTALL	9905-330-004

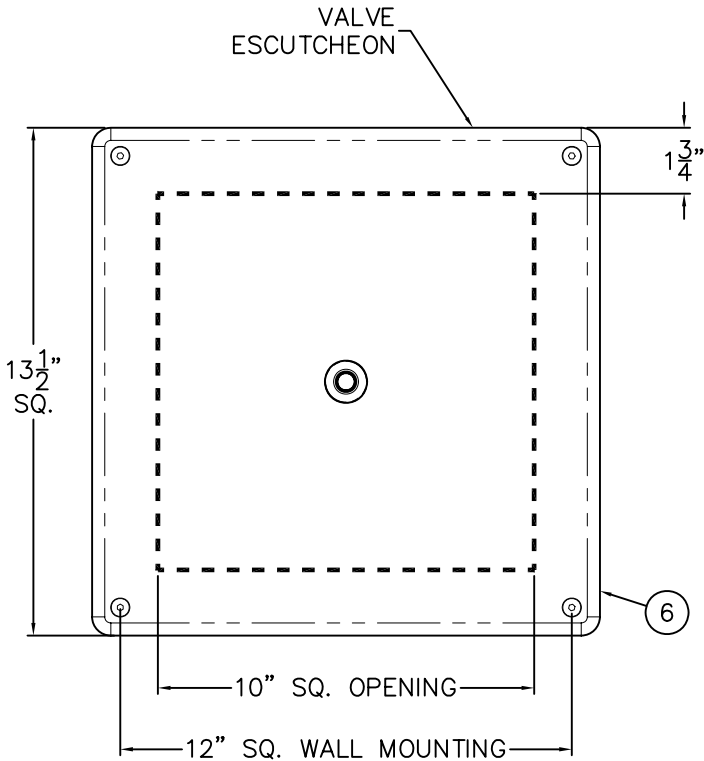

**INSTALLATION INSTRUCTIONS:**

- A-DETERMINE LOCATION OF VALVE (1) AND INSTALL SUPPORT FRAMING IF REQUIRED.
- B-MOUNT SOLENOID VALVE (1) AND MAKE UP CONNECTIONS TO VALVE RISER (2) OUTLET AND SHOWER HEAD. NOTE: VALVE MAY BE REMOTELY LOCATED UP TO 10 FEET FROM PUSHBUTTON (3) OR SHOWER HEAD.
- D-AFTER THOROUGHLY FLUSHING SUPPLY LINE (4), CONNECT SUPPLY TO 1/2" NPS FLEX HOSE VALVE INLET (5). NOTE: SUPPLY INLET WILL ACCOMMODATE 1/2" NPT MALE ADAPTER.
- E-MOUNT PUSHBUTTON TO PANEL (6) AND MAKE UP CONNECTIONS TO 1/8" OD AIR LINE AND VALVE ELECTRONIC CONTROLLER.

- F-MOUNT VALVE ESCUTCHEON (6) OVER OPENING WITH INSTALLER PROVIDED WALL ANCHORS & FASTENERS PROVIDED (7). SEAL VALVE ESCUTCHEON AND WALL WITH INSTALLER PROVIDED SEALANT.
- G-REFER TO SPECIFIC ELECTRONIC CONTROLLER INSTALL SHEET FOR FURTHER DETAILS.

**REFER TO ADA GUIDELINES FOR COMPLETE INSTALLATION REQUIREMENTS.**

<p>ACORN ENGINEERING COMPANY P.O. BOX 3527 Industry, CA 91744 15125 Proctor Ave Industry, CA 91746 (626) 336-4561 FAX (626) 961-2200</p>	<p>TITLE <b>ZENITH ELECTRONIC VALVE, SINGLE TEMP, #510, #530</b></p>	
	<p>MANUFACTURE DATE <b>SEPTEMBER 1995</b> <b>TO PRESENT</b></p>	<p>DATE ISSUED <b>06/20/97</b></p> <p>DATE REVISED <b>04/26/12</b></p>

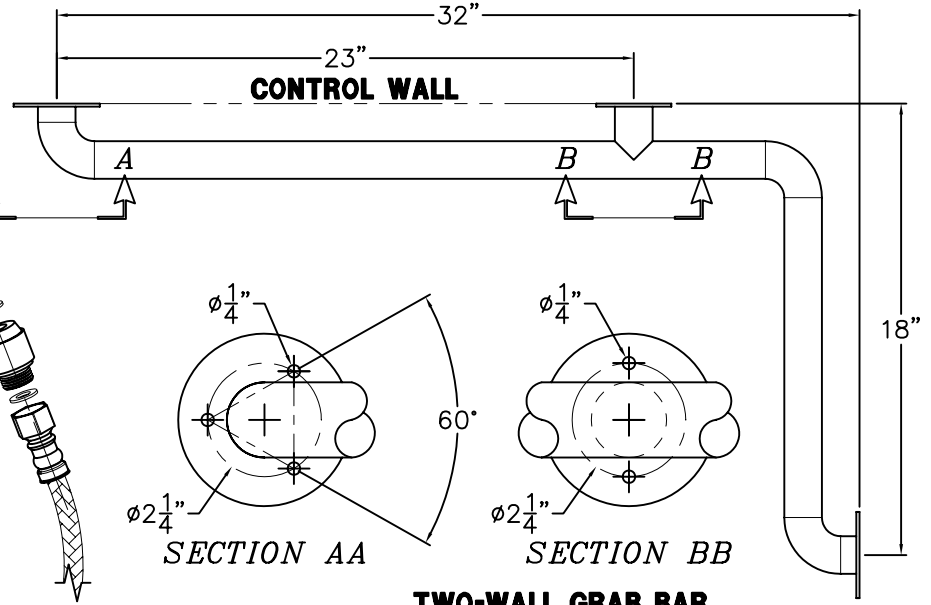
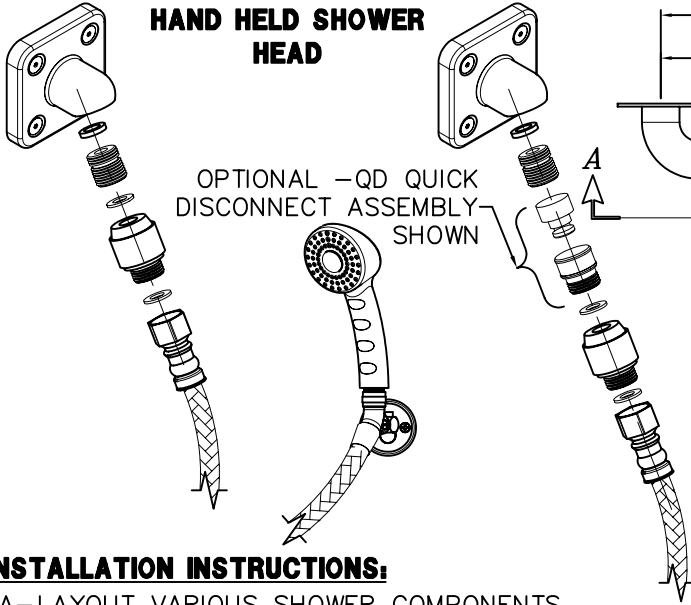

**INSTALLATION INSTRUCTIONS:**

- A-LAYOUT VARIOUS SHOWER COMPONENTS CONSULTING CURRENT ADA GUIDELINES AND/OR LOCAL CODE AUTHORITY FOR COMPLETE ACCESSIBILITY INSTALLATION REQUIREMENTS.
- B-ENSURE ADEQUATE WALL BACKING IS PROVIDED FOR WEIGHT BEARING COMPONENT ASSEMBLIES SUCH AS SHOWER SEATS AND GRAB BARS. LOAD RATINGS WILL BE LIMITED BY THE WALL TYPE CONSTRUCTION AND ANCHORING HARDWARE USED.
- C-USE APPROPRIATE COMPONENT INSTALLATION SHEETS FOR SPECIFIC SHOWER HEAD, VALVE, ACCESSORIES AND OPTIONS REQUIRED.
- D-ALL WALL ANCHORS AND ANCHORING HARDWARE ARE PROVIDED BY THE INSTALLER. IT IS THE RESPONSIBILITY OF THE INSTALLER TO ENSURE THAT ALL WALL ANCHORING HARDWARE ARE APPROPRIATE FOR TYPE WALL CONSTRUCTION.
- E-MOUNT HAND SHOWER WALL BRACKET TO WALL USING APPROPRIATE ANCHORING HARDWARE OR THE SCREWS AND WALL ANCHORS PROVIDED.
- F-MOUNT GRAB BAR AS WALL CONDITIONS REQUIRE, USING APPROPRIATE ANCHORING HARDWARE PROVIDED BY INSTALLER OR CENTER REJECT SCREWS PROVIDED.
- G-ASSEMBLE FLEX HOSE TO HAND HELD SHOWER AND WALL MOUNTED SHOWER HEAD. HINT: USE TEFLON TAPE FOR ALL THREADED CONNECTIONS TO REDUCE THE POSSIBILITY OF LEAKAGE.
- H-INSERT RECESSED SOAP DISH INTO WALL. NOTE: PLASTER FLANGE IS 3/4" FROM FINISHED WALL.

**TWO-WALL GRAB BAR**

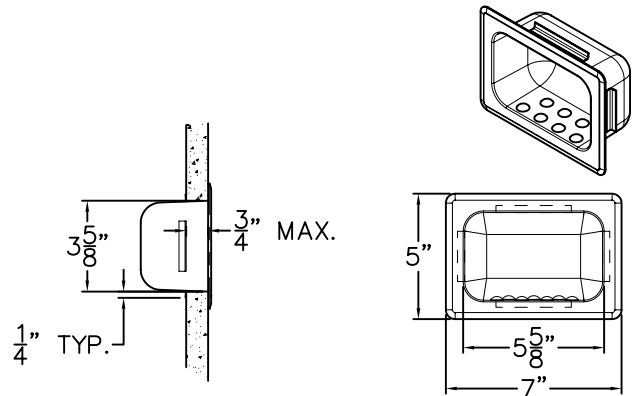

**RECESSED SOAP DISH**

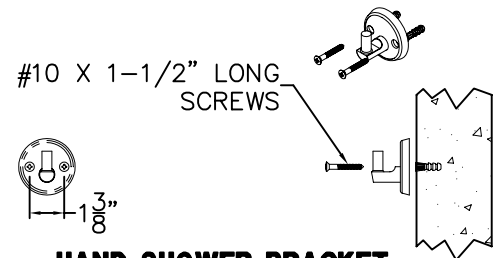

**HAND SHOWER BRACKET**

**NOTE: REFER TO ADA ACCESSIBILITY GUIDELINES FOR COMPLETE INSTALLATION REQUIREMENTS.**

<b>REFERENCE DRAWINGS</b>	
FLEX HAND SHOWER	9970-102-003
FOLDING PADDED SEAT INSTALL	9900-350-001
DIVERTER INSTALL w/ PUSH-IN CONN	9900-327-001
DIVERTER INSTALL w/ 1/2" NCT CONN	9900-328-001

**ACORN ENGINEERING COMPANY**  
 P.O. BOX 3527 INDUSTRY, CA. 91744  
 (626) 336-4561 FAX (626) 961-2200

TITLE **ZENITH ADA SHOWERS -COMPONENTS**

MANUFACTURE DATE

**MAY 2004  
 TO PRESENT**

DATE ISSUED

**12/01/89**

DATE REVISED

**04/10/11**

DRAWING NUMBER

**9900-325-002**

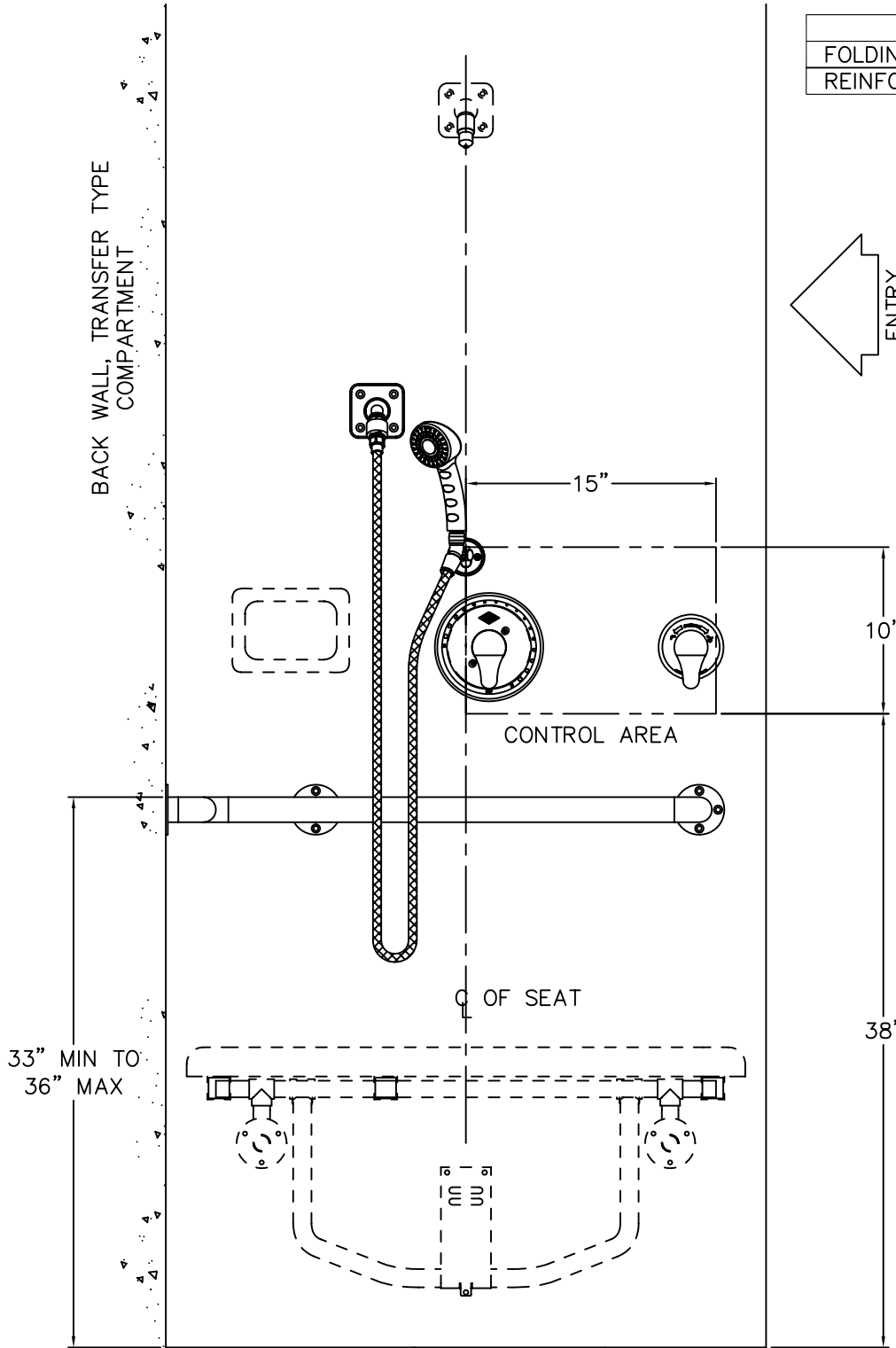

REFERENCE DRAWINGS	
FOLDING PADDING SEAT	9900-350-001
REINFORCED PANEL	9900-351-002

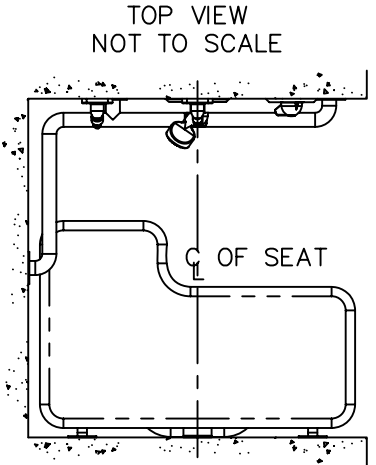
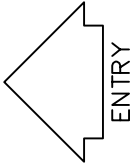

**36" x 36" TRANSFER TYPE COMPARTMENT SHOWN**

- A- REFER TO ADA GUIDELINES OR LOCAL CODE AUTHORITY FOR COMPLETE INSTALLATION REQUIREMENTS FOR YOUR COMPARTMENT.
  - B- COMPLIANCE IS SUBJECT TO THE INTERPRETATION AND REQUIREMENTS OF THE LOCAL CODE AUTHORITY.
- FYI: YOUR LOCAL CODE AUTHORITY MAY REQUIRE A DIFFERENT LAYOUT THAN SHOWN.

ACORN ENGINEERING COMPANY P.O. BOX 3527 INDUSTRY, CA. 91744 (626) 336-4561 FAX (626) 961-2200	TITLE <b>ZENITH ADA LAYOUT</b>	
	MANUFACTURE DATE <b>MAY 2004</b> <b>TO PRESENT</b>	DATE ISSUED <b>04/10/11</b> DATE REVISED <b>06/01/11</b>

REFERENCE DRAWINGS	
DIVERTER PARTS	9975-080-002

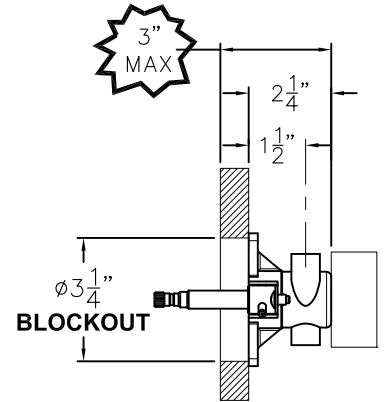
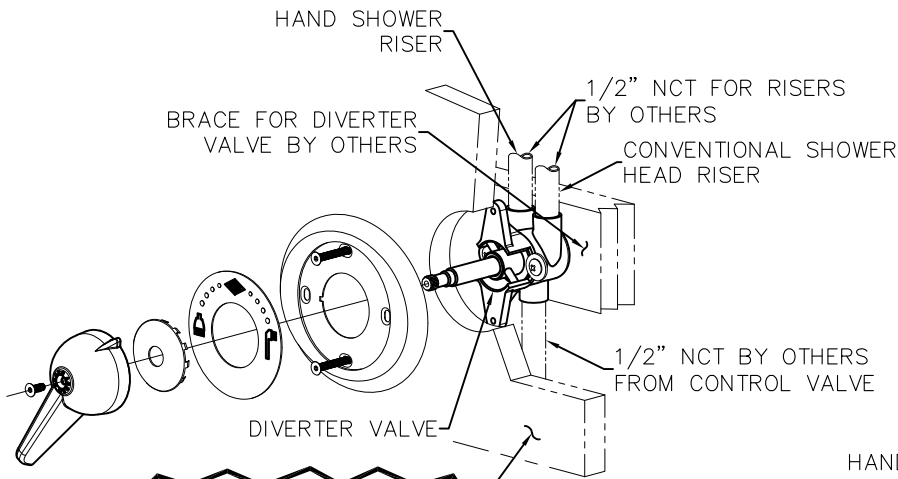

THICKNESS OF WALL 5/8"  
MINIMUM TO 3/4" MAXIMUM

**DIVERTER VALVE FOR -5 FLO-CLOZ  
AND -6 AIR-CONTROL**

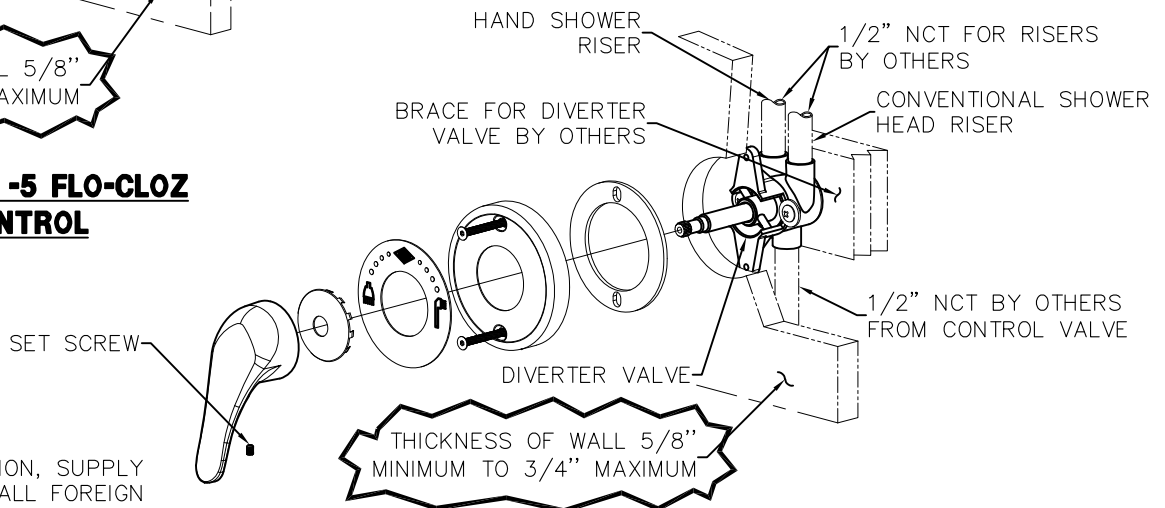

THICKNESS OF WALL 5/8"  
MINIMUM TO 3/4" MAXIMUM

**DIVERTER VALVE FOR -8 LEVER HANDLE**

**WARNING:** PRIOR TO INSTALLATION, SUPPLY LINES MUST BE FLUSHED OF ALL FOREIGN MATERIAL SUCH AS PIPE DOPE, CHIPS, SOLDER ETC. VALVE MUST BE DRAINED PRIOR TO BEING SUBJECTED TO FREEZING TEMPERATURES.

**NOTE:** ENSURE DRAIN HOLE IS ON BOTTOM

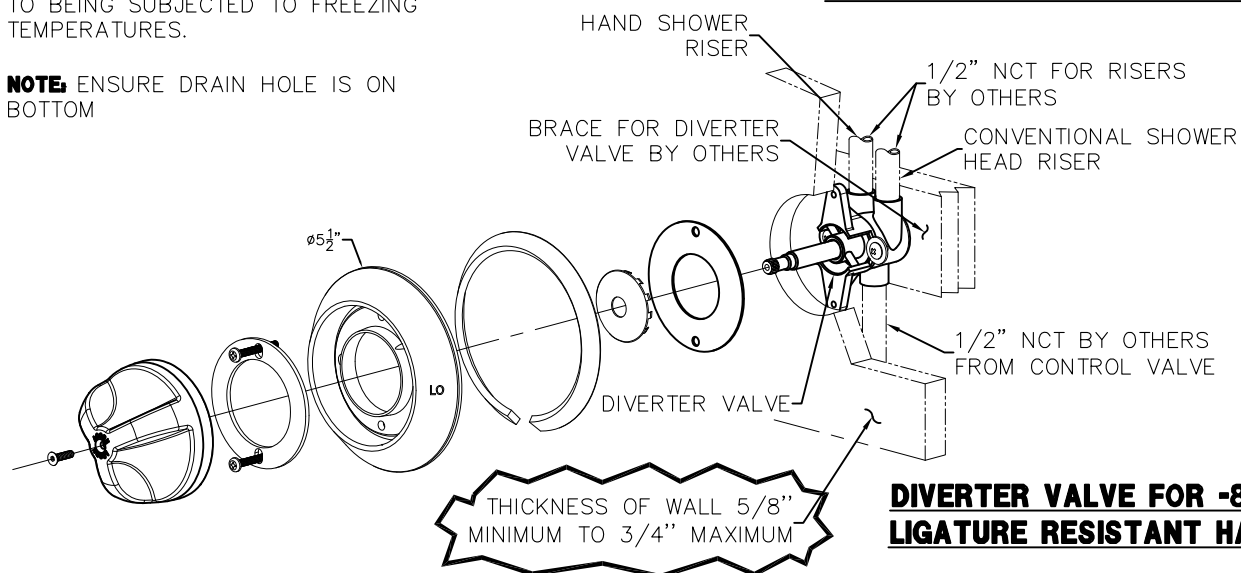

THICKNESS OF WALL 5/8"  
MINIMUM TO 3/4" MAXIMUM

**DIVERTER VALVE FOR -8 -LRH  
LIGATURE RESISTANT HANDLE**

<p><b>MORRIS GROUP INTL</b> P.O. BOX 3527 Industry, CA 91744 MORRIS GROUP 15125 Proctor Ave Industry, CA 91746 INTERNATIONAL (626) 336-4561 FAX (626) 961-2200</p>	<p>TITLE <b>ZENITH DIVERTER VALVE INSTALLATION FOR 1/2" NCT</b></p>	
	<p>MANUFACTURE DATE <b>FEBRUARY 2010</b> <b>TO PRESENT</b></p>	<p>DATE ISSUED <b>02/01/14</b></p> <p>DATE REVISED <b>07/11/22</b></p>

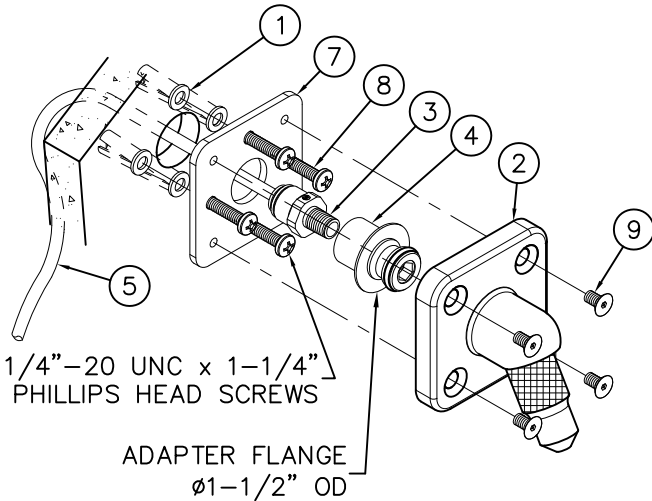

**SHOWERHEAD HAVING -A ANCHOR PLATE OPTION FOR ZENITH WITH 3/8" PE TUBING RISER CONNECTION**

PRIOR TO MAKING UP CONNECTIONS TO VALVE ASSEMBLY, FLUSH SUPPLY LINES THOROUGHLY. INSTALL WALL ANCHORS ① BY OTHERS USING -A ANCHOR PLATE ⑦ AS A TEMPLATE. ASSEMBLE 3/8" O.D. x 1/4" NPT PUSH-IN FITTING ③ TO O-RING ADAPTER ④. AFTER PULLING 3/8" OD PE TUBING ⑤ THRU WALL AND ANCHOR PLATE ⑦ OPENINGS, PUSH INTO FITTING ③ AND PULL TO LOCK. SECURE ANCHOR PLATE ⑦ TO WALL WITH SCREWS ⑧ PROVIDED. PUSH O-RING ADAPTER ASSEMBLY INTO SHOWERHEAD ②. INSTALL ASSEMBLY TO ANCHOR PLATE ⑦ USING SCREWS ⑨ PROVIDED.

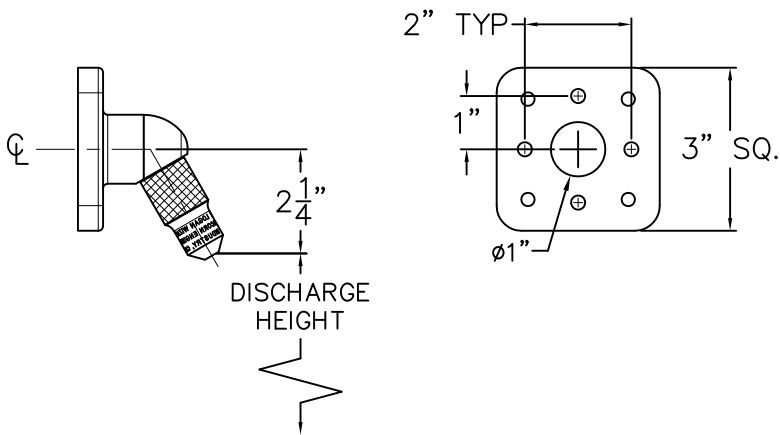

REFERENCE DRAWINGS	
ASSEMBLIES	NUMBER
SHOWERHEAD	9970-105-004
NOZZLE	9970-101-004
ANCHOR PLATE	9970-150-003

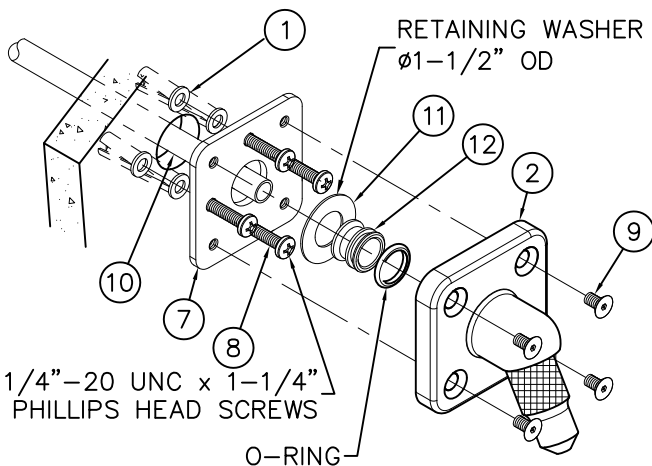

**SHOWERHEAD HAVING -A ANCHOR PLATE OPTION FOR ZENITH WITH 1/2" NCT RISER CONNECTION**

PRIOR TO MAKING UP CONNECTIONS TO VALVE ASSEMBLY, FLUSH SUPPLY LINES THOROUGHLY. USE ANCHOR PLATE ⑦ AS A TEMPLATE AND INSTALL WALL ANCHORS ① BY OTHERS. INSTALL 1/2" NCT SHOWER RISER ⑩ BY OTHERS THRU WALL, ANCHOR PLATE ⑦ AND STUB-OUT EXTENDED 1" FROM BEYOND WALL. PLACE RETAINING WASHER ⑪ AND O-RING ADAPTER ⑫ OVER STUB-OUT ⑩ AND POSITION AGAINST ANCHOR PLATE ⑦. REMOVE O-RING BEFORE SOLDERING O-RING ADAPTER ⑫ TO STUB-OUT ⑩. REINSTALL O-RING AND INSTALL SHOWERHEAD ② TO ANCHOR PLATE ⑦ USING SCREWS ⑨ PROVIDED.

ACORN ENGINEERING COMPANY  
P.O. BOX 3527 Industry, CA 91744  
15125 Proctor Ave Industry, CA 91746  
(626) 336-4561 FAX (626) 961-2200

TITLE <b>INSTALLATION OF FLANGED BRACKET SHOWERHEADS w/ -A ANCHOR PLATE</b>		
MANUFACTURE DATE <b>JULY 1975 TO PRESENT</b>	DATE ISSUED <b>09/29/04</b>	DRAWING NUMBER <b>9900-320-003</b>
	DATE REVISED <b>01/27/14</b>	



**SHOWERHEAD HAVING -B BACK PLATE OPTION  
FOR ZENITH WITH 3/8" PE TUBING RISER  
CONNECTION**

FLUSH SUPPLY LINES THOROUGHLY PRIOR TO MAKING UP CONNECTIONS TO VALVE ASSEMBLY. USE RETAINER PLATE ① AS A TEMPLATE TO CREATE THRU WALL OPENINGS. ASSEMBLE 3/8" O.D. x 1/4" NPT PUSH-IN FITTING ② TO O-RING ADAPTER ③. AFTER PASSING 3/8" O.D. PE TUBING ④ THRU BACK PLATE ⑤, WALL AND RETAINER PLATE ① OPENINGS, PUSH INTO FITTING ② AND PULL TO LOCK. ASSEMBLE MOUNTING STUDS ⑥ TO SHOWERHEAD ⑦ & PASS THRU RETAINER PLATE ① AND THEN THRU THE WALL. FROM CHASE SIDE, INSTALL BACK PLATE ⑤ AND SECURE WHOLE ASSEMBLY WITH NUTS AND WASHERS ⑧.

REFERENCE DRAWINGS	
ASSEMBLIES	NUMBER
NOZZLE	9970-101-004
WALL PLATES	9970-151-003

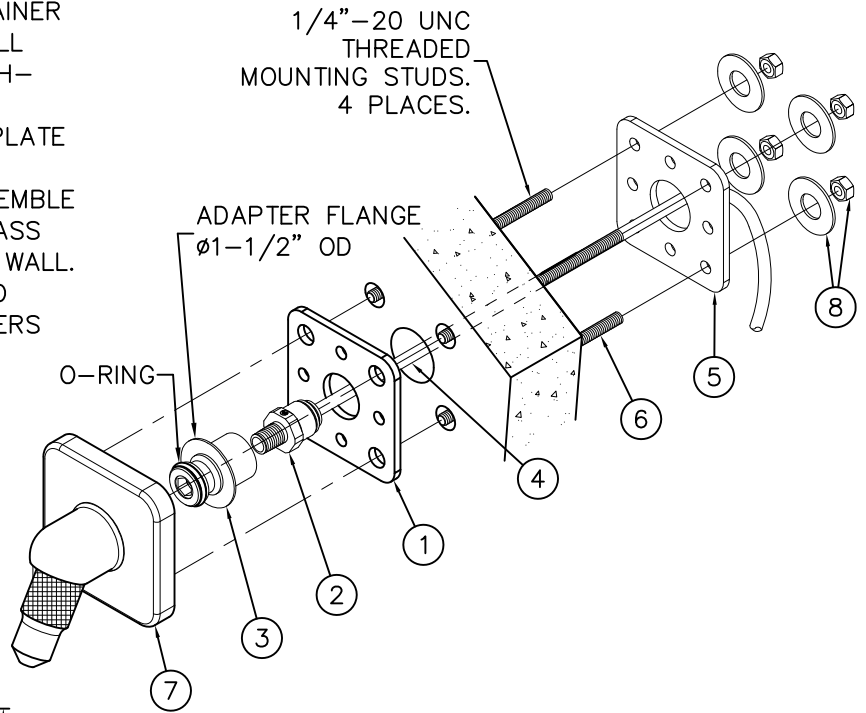
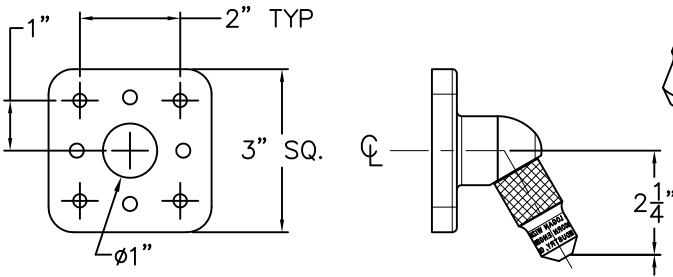

**SHOWERHEAD HAVING -B BACK PLATE OPTION  
FOR ZENITH WITH 1/2" NCT RISER CONNECTION**

FLUSH SUPPLY LINES THOROUGHLY PRIOR TO MAKING UP CONNECTIONS TO VALVE ASSEMBLY. USE RETAINER PLATE ① AS A TEMPLATE TO CREATE THRU WALL OPENINGS. PASS 1/2" NCT RISER ⑨ THRU BACK PLATE ⑤, WALL & RETAINER PLATE ① EXTENDING 1" BEYOND THE RETAINER PLATE. PASS RETAINING WASHER ⑩ THRU RISER STUB OUT. SLIDE O-RING ADAPTER ⑪ ONTO STUB OUT AND AGAINST RETAINING WASHER ⑩. REMOVE O-RING AND SOLDER ADAPTER ⑪ TO RISER. INSTALL O-RING WHEN COOL. ASSEMBLE MOUNTING STUDS ⑥ TO SHOWER HEAD ⑦ & PASS THRU RETAINER PLATE ① AND THEN THRU WALL. FROM CHASE SIDE, INSTALL BACK PLATE ⑤ AND SECURE ASSEMBLY WITH NUTS AND WASHERS ⑧ PROVIDED.

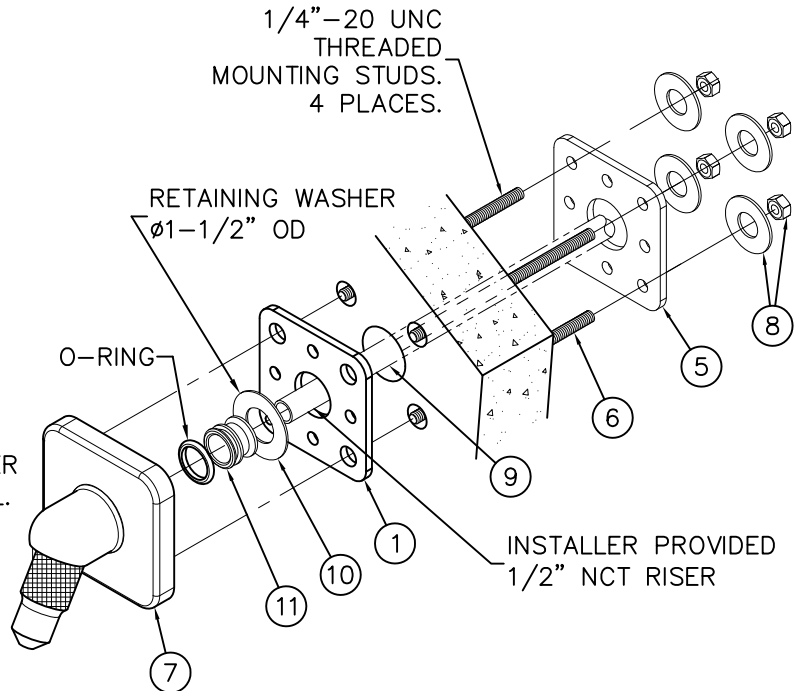

**ACORN ENGINEERING COMPANY**  
P.O. BOX 3527 Industry, CA 91744  
15125 Proctor Ave Industry, CA 91746  
(626) 336-4561 FAX (626) 961-2200

**INSTALLATION OF FLANGED BRACKET SHOWERHEADS w/ -B BACK PLATE**

MANUFACTURE DATE

**JULY 1977  
TO PRESENT**

DATE ISSUED

**09/29/04**

DATE REVISED

**01/27/14**

DRAWING NUMBER

**9900-321-002**

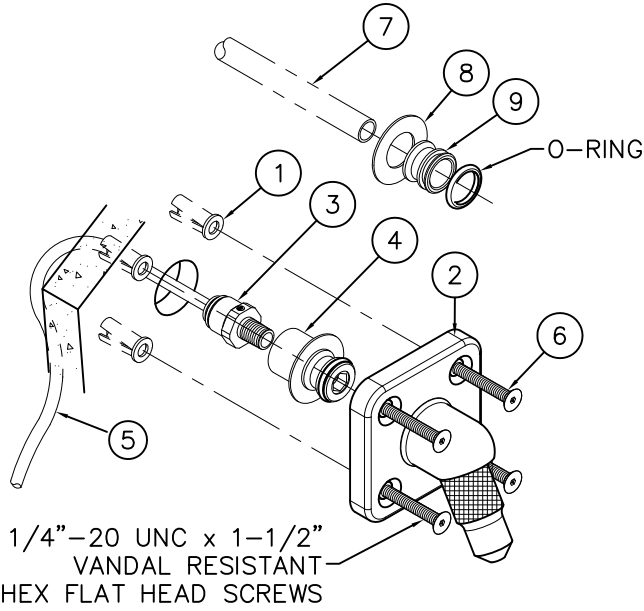

**ZENITH SHOWERHEAD w/ 3/8" PE TUBING OR 1/2" NCT RISER BY OTHERS**

PRIOR TO MAKING UP CONNECTIONS TO VALVE ASSEMBLY, FLUSH SUPPLY LINES THOROUGHLY. INSTALL WALL ANCHORS (1) BY OTHERS USING SHOWERHEAD BASE (2) AS A TEMPLATE.

**FOR 3/8" PE TUBING RISER:** ASSEMBLE 3/8" OD x 1/4" NPT PUSH-IN FITTING (3) TO O-RING ADAPTER (4). AFTER PULLING 3/8" OD PE TUBING (5) THRU WALL OPENING PUSH INTO FITTING (3) AND PULL TO LOCK. PUSH O-RING ADAPTER ASSEMBLY INTO SHOWERHEAD (2). INSTALL ASSEMBLY TO WALL USING SCREWS (6) PROVIDED.

**FOR 1/2" NCT RISER:** STUB-OUT 1/2" NCT RISER (7) BY OTHERS EXTENDED 1" BEYOND WALL. INSTALL RETAINING WASHER (8) AND O-RING ADAPTER (9) OVER STUB-OUT (7) AND POSITION AGAINST WALL. REMOVE O-RING BEFORE SOLDERING O-RING ADAPTER (9) TO STUB-OUT (7). REINSTALL O-RING AND POSITION SHOWERHEAD (2) OVER ADAPTER ASSEMBLY. SECURE USING SCREWS (6) PROVIDED.

NOTE: Use Of Teflon Tape On All Threaded Connections Is Recommended.

REFERENCE DRAWINGS	
ASSEMBLIES	NUMBER
NOZZLE	9970-101-004
SHOWERHEAD	9970-105-004
BENT ARM	9970-100-003

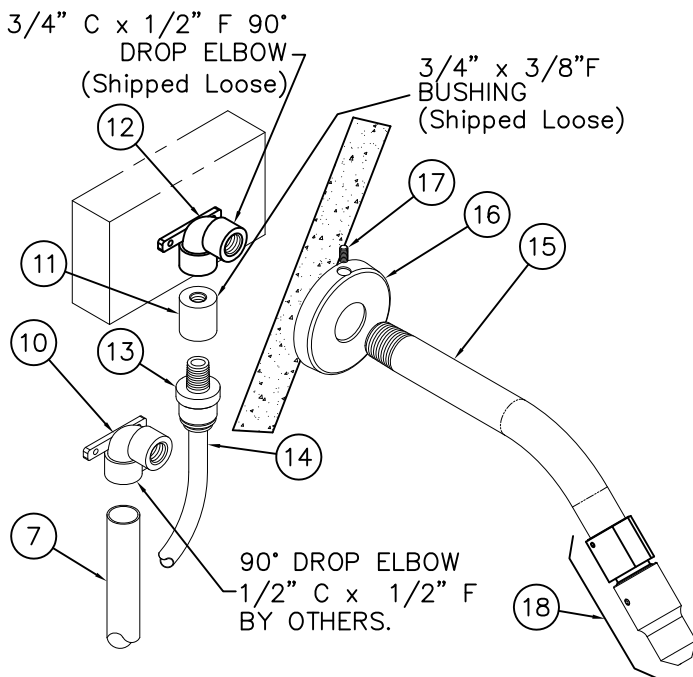
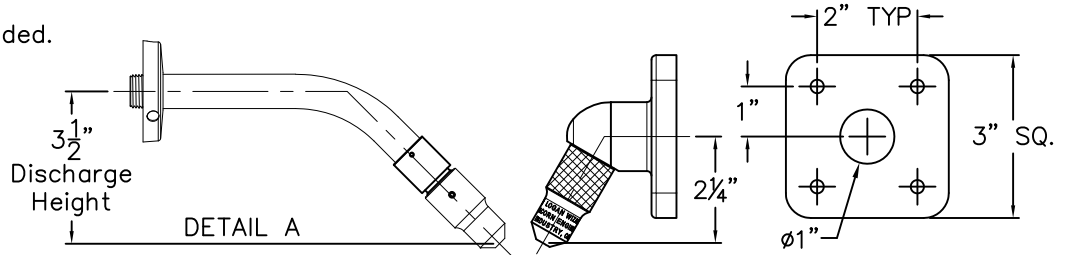

**ZENITH -BA BENT ARM OPTION w/ 3/8" OD PE TUBING OR w/ 1/2" NCT RISER BY OTHERS**

PRIOR TO MAKING UP CONNECTIONS TO VALVE ASSEMBLY, FLUSH SUPPLY LINES THOROUGHLY.

**FOR 1/2" NCT RISER:** BRING UP 1/2" NCT RISER (7) BY OTHERS, FROM VALVE AND CONNECT TO 1/2" C x 1/2" F ELBOW (8) BY OTHERS. SECURE ELBOW (8) AT DERIVED HEIGHT (SEE DETAIL A).

**FOR 3/8" PE TUBING:** SWEAT 3/4" x 3/8" F BUSHING (11) TO 3/4" C x 3/8" F ELBOW (12). LET COOL PRIOR TO CONNECTING 3/8" OD x 3/8" NPT PUSH-IN FITTING (13). BRING UP 3/8" OD TUBING RISER (14) FROM VALVE AND PUSH INTO FITTING (13) AND PULL TO LOCK. SECURE ELBOW ASSEMBLY (12) AT THE DERIVED HEIGHT (SEE DETAIL A).

**BOTH RISER TYPES:** PASS THREADED END OF BENT ARM (15) ASSEMBLY THRU LOOSE ESCUTCHEON (16) AND CONNECT TO THE FIXED ELBOW ASSEMBLY (12). POSITION ESCUTCHEON (16) AGAINST FINISHED WALL AND SECURE USING THE SET SCREW (17) PROVIDED. CONNECT THE NOZZLE ASSEMBLY (18).

<p>ACORN ENGINEERING COMPANY P.O. BOX 3527 Industry, CA 91744 15125 Proctor Ave Industry, CA 91746 (626) 336-4561 FAX (626) 961-2200</p>	<p>TITLE <b>FLANGED BRACKET SHOWERHEAD &amp; -BA BENT ARM</b></p>		
	<p>MANUFACTURE DATE</p> <p><b>JULY 1977</b></p> <p><b>TO PRESENT</b></p>	<p>DATE ISSUED</p> <p><b>11/01/06</b></p>	<p>DRAWING NUMBER</p> <p><b>9900-322-001</b></p>
		<p>DATE REVISED</p> <p><b>01/28/14</b></p>	

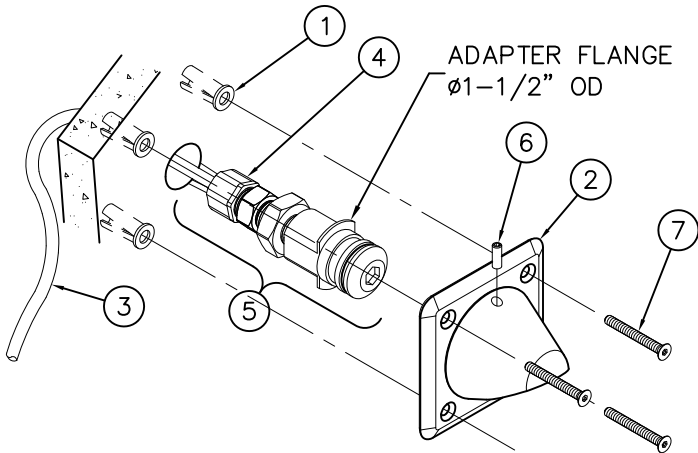

**-CSH CONICAL SHOWERHEAD OPTION FOR ZENITH w/ 3/8" PE TUBING RISER CONNECTION**

PRIOR TO MAKING UP CONNECTIONS TO VALVE ASSEMBLY, FLUSH SUPPLY LINES THOROUGHLY. INSTALL WALL ANCHORS ① BY OTHERS USING -CSH PLATE ② AS A TEMPLATE. AFTER PASSING 3/8" PE TUBING ③ THRU WALL OPENING MAKE UP CONNECTION TO 3/8" TUBE x 3/8" NPT COMPRESSION FITTING ④ AND PUSH ADAPTER ASSEMBLY ⑤ INTO CSH ASSEMBLY. TIGHTEN SET SCREW ⑥ ON -CSH. SECURE MOUNTING PLATE TO WALL USING SCREWS ⑦ PROVIDED.

VANDAL RESISTANT #10-32 UN x 1-1/2" LONG FLAT HEAD SCREWS WITH CENTER REJECT PIN

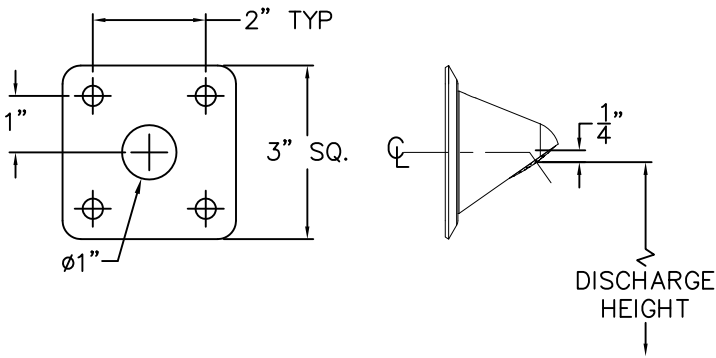

REFERENCE DRAWINGS	
ASSEMBLIES	NUMBER
SHOWERHEAD	9970-009-001

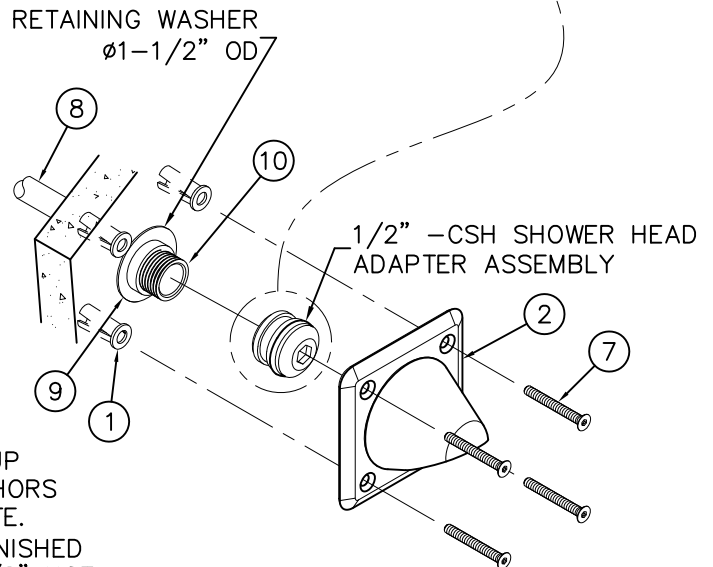
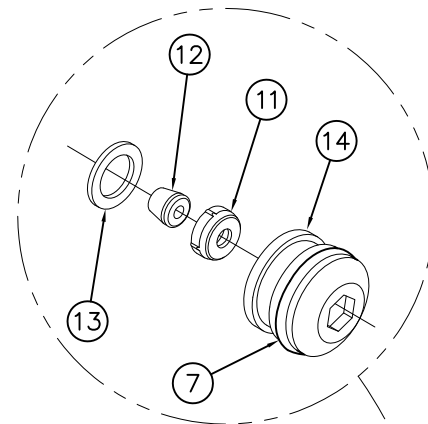

**-CSH CONICAL SHOWERHEAD OPTION FOR ZENITH WITH 1/2" NCT RISER CONNECTION**

FLUSH SUPPLY LINES THOROUGHLY, PRIOR TO MAKING UP CONNECTIONS TO VALVE ASSEMBLY. INSTALL WALL ANCHORS ① BY OTHERS USING -CSH PLATE ② AS A TEMPLATE. EXTEND 1/2" NCT RISER ⑧ BY OTHERS 1" BEYOND FINISHED WALL. THREAD RETAINING WASHER ⑨, AND SOLDER 1/2" NCT x BSP ADAPTER ⑩ ONTO RISER. ASSEMBLE FLOW CONTROL RETAINER ⑪, FLOW CONTROL ⑫ AND NEOPRENE WASHER ⑬ ONTO SHOWER HEAD ADAPTER ⑭. TIGHTEN ASSEMBLY ONTO ADAPTER ⑩ & SECURE -CSH USING SCREWS ⑦ PROVIDED.

ACORN ENGINEERING COMPANY P.O. BOX 3527 Industry, CA 91744 15125 Proctor Ave Industry, CA 91746 (626) 336-4561 FAX (626) 961-2200	TITLE <b>ZENITH CONICAL SHOWER HEAD</b>		
	MANUFACTURE DATE <b>JULY 1998</b> <b>TO PRESENT</b>	DATE ISSUED <b>03/16/11</b>	DRAWING NUMBER <b>9900-323-001</b>
		DATE REVISED <b>01/27/14</b>	





REFERENCE DRAWINGS	
ASSEMBLIES	NUMBER
SHOWERHEAD	9970-009-001

**-CSH CONICAL SHOWERHEAD OPTION WITH -B BACK PLATE OPTION FOR ZENITH WITH 3/8" PE TUBE RISER CONNECTION**

PRIOR TO MAKING UP CONNECTIONS TO VALVE ASSEMBLY, FLUSH SUPPLY LINES THOROUGHLY. USE BACK PLATE ① AS A TEMPLATE TO CREATE THRU WALL OPENINGS. PASS 3/8" PE TUBING ② THRU BACK PLATE ① AND MAKE UP CONNECTION TO 3/8" NPT COMPRESSION FITTING ③. PUSH ADAPTER ASSEMBLY ④ INTO -CSH ASSEMBLY. TIGHTEN SET SCREW ⑤ ON -CSH. ASSEMBLE MOUNTING STUDS ⑥ TO SHOWER FLANGE ⑦ AND SLIDE THRU THE WALL OPENINGS. FROM CHASE SIDE, SECURE ASSEMBLY WITH NUTS AND WASHERS ⑧ PROVIDED.

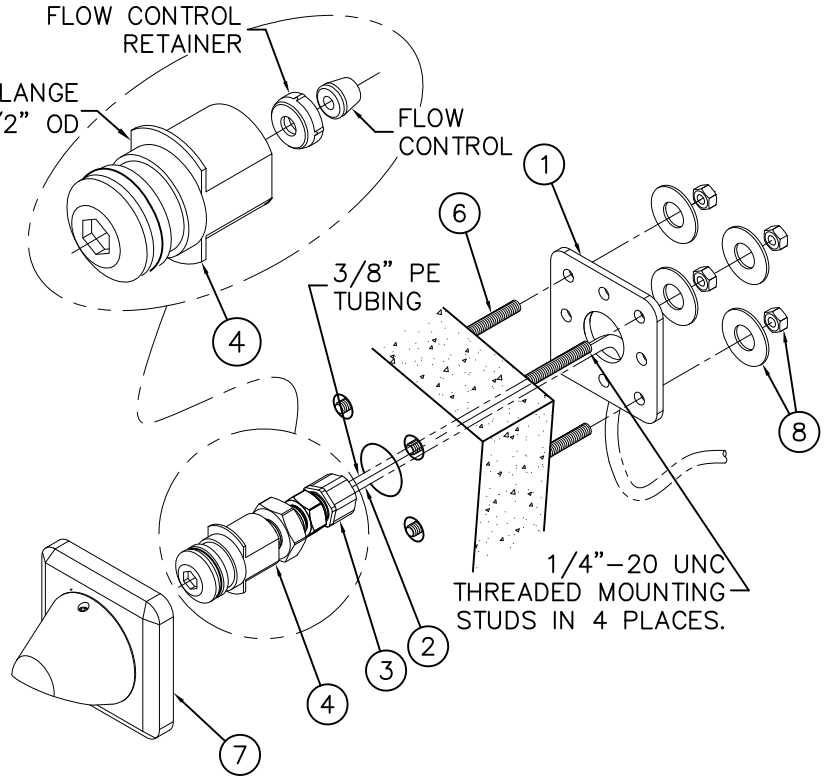

**-CSH CONICAL SHOWERHEAD OPTION WITH -B BACK PLATE OPTION FOR ZENITH WITH 1/2" NCT RISER CONNECTION**

PRIOR TO MAKING UP CONNECTIONS TO VALVE ASSEMBLY, FLUSH SUPPLY LINES THOROUGHLY. USE BACK PLATE ① AS A TEMPLATE TO CREATE THRU WALL OPENINGS. PASS 1/2" NCT SHOWER HEAD RISER ⑨ THRU BACK PLATE ① AND EXTEND 1" BEYOND WALL. PASS RETAINING WASHER ⑩ ONTO RISER STUB OUT. SLIDE 1/2" BSP X 1/2" NCT BRASS ADAPTER ⑪ ONTO RISER AND SOLDER. ASSEMBLE THE O-RING ADAPTER ⑫ AS SHOWN AND TIGHTEN ONTO THE BRASS ADAPTER ⑪. ASSEMBLE MOUNTING STUDS ⑥ TO THE SHOWER FLANGE ⑦ AND SLIDE THRU THE WALL OPENINGS. FROM CHASE SIDE, SECURE ASSEMBLY WITH NUTS AND WASHERS ⑧ PROVIDED.

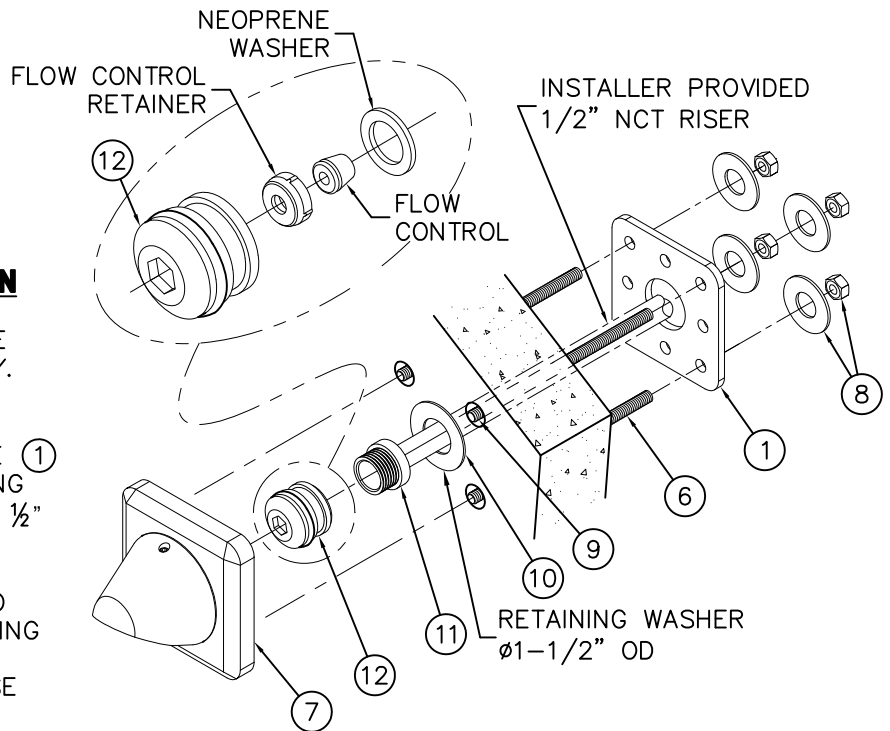

ACORN ENGINEERING COMPANY P.O. BOX 3527 Industry, CA 91744 15125 Proctor Ave Industry, CA 91746 (626) 336-4561 FAX (626) 961-2200	TITLE <b>ZENITH CONICAL SHOWER HEAD W/-B BACK PLATE</b>		
	MANUFACTURE DATE <b>JULY 1998</b> <b>TO PRESENT</b>	DATE ISSUED <b>09/15/11</b> DATE REVISED <b>01/28/14</b>	DRAWING NUMBER <b>9900-324-001</b>



BACK VIEW

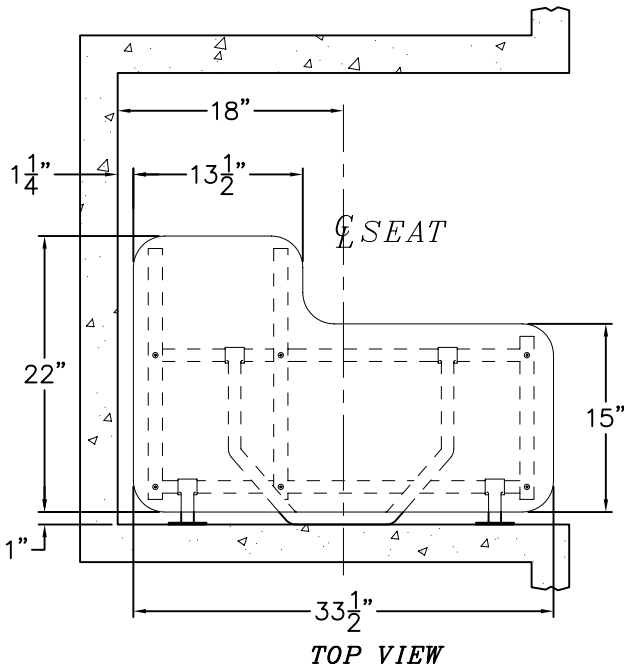
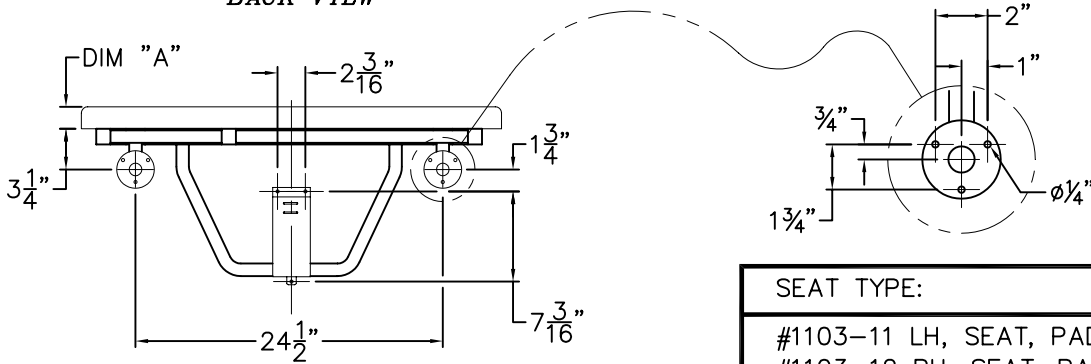

SEAT TYPE:	DIM 'A'
#1103-11 LH, SEAT, PADDED #1103-12 RH, SEAT, PADDED	3/4"
#1103-21 LH, SEAT, PHENOLIC #1103-22 RH, SEAT, PHENOLIC	1/2"
#1103-31 LH, SEAT, SS #1103-32 RH, SEAT, RH	1/8"

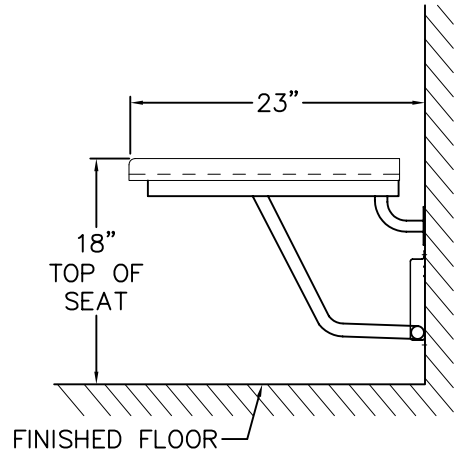

REFERENCE DRAWING	
-RD REINFORCED PANEL	9900-351-001

**INSTALLATION INSTRUCTIONS:**

A- USING FOLDED SEAT FRAME AS A TEMPLATE MARK HOLES ON WALL OR REINFORCED PANEL FOR MOUNTING FLANGES AND SUPPORT LEG GUIDE BRACKET FOR WALL ANCHORS AND ANCHORING HARDWARE BY OTHERS. FOR -RP PANEL MOUNTING, #10 x 1" LONG STAINLESS STEEL PHILIPS HEAD SHEET METAL SCREWS ARE RECOMMENDED. FOR WALL MOUNTING, #10 x 2" LONG STAINLESS STEEL PHILIPS HEAD SHEET METAL SCREWS ARE RECOMMENDED.

- B- SEAT SHOULD BE MOUNTED ON CENTER WITH 34" WIDE ACORN -RP REINFORCED PANEL. REFER TO PANEL DETAIL WITH JOB INSTALLATION INSTRUCTIONS FOR CUSTOM PANEL SIZE INFORMATION.
- C- THE SEAT IS PROPERLY INSTALLED IF IT FOLDS UP AND DOWN FREELY, YET STAYS IN THE UP POSITION WITHOUT ASSISTANCE.

CONSULT APPLICABLE CODES FOR SEAT HEIGHT & LOCATION REQUIREMENTS. RECOMMENDED SEAT HEIGHT IS 18" ABOVE FINISHED FLOOR.

IMPORTANT: THIS SHOWER SEAT IS INTENDED TO MEET OR EXCEED CURRENT ADA CODE REQUIREMENTS. SEAT REQUIRES ADEQUATE IN-WALL, WALL BACKING OR OTHER SECURE METHOD OF ANCHORING.



ACORN ENGINEERING COMPANY  
P.O. BOX 3527 INDUSTRY, CA. 91744  
(626) 336-4561 FAX (626) 961-2200

TITLE		
<b>FOLDING PADDED SEAT CATALOG * 1103 SERIES (A.D.A.)</b>		
MANUFACTURE DATE	DATE ISSUED	DRAWING NUMBER
<b>JANUARY 1, 1980</b>	<b>04/07/93</b>	<b>9900-350-001</b>
<b>TO PRESENT</b>	DATE REVISED	
	<b>09/13/10</b>	



**EVS1-MA2 WIRING DIAGRAM SHOWN FOR REFERENCE ONLY**

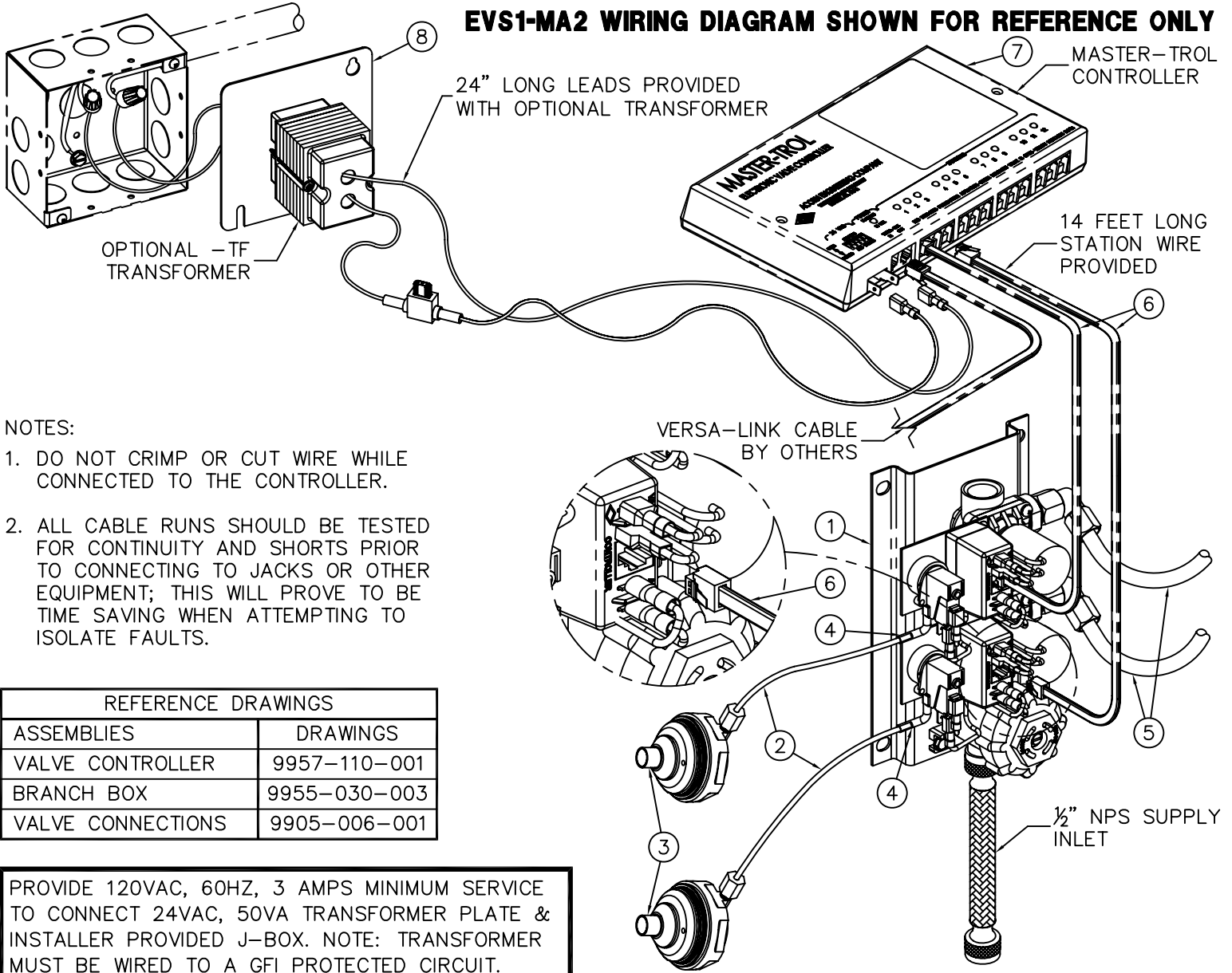

**NOTES:**

1. DO NOT CRIMP OR CUT WIRE WHILE CONNECTED TO THE CONTROLLER.
2. ALL CABLE RUNS SHOULD BE TESTED FOR CONTINUITY AND SHORTS PRIOR TO CONNECTING TO JACKS OR OTHER EQUIPMENT; THIS WILL PROVE TO BE TIME SAVING WHEN ATTEMPTING TO ISOLATE FAULTS.

REFERENCE DRAWINGS	
ASSEMBLIES	DRAWINGS
VALVE CONTROLLER	9957-110-001
BRANCH BOX	9955-030-003
VALVE CONNECTIONS	9905-006-001

PROVIDE 120VAC, 60HZ, 3 AMPS MINIMUM SERVICE TO CONNECT 24VAC, 50VA TRANSFORMER PLATE & INSTALLER PROVIDED J-BOX. NOTE: TRANSFORMER MUST BE WIRED TO A GFI PROTECTED CIRCUIT.

**INSTALLATION INSTRUCTIONS:**

- A. ROUGH-IN & INSTALL FIXTURE PER MANUFACTURER'S INSTRUCTIONS.
- B. MOUNT SOLENOID VALVE ASSEMBLY (1) WITHIN THE CHASE OR FIXTURE FRAME / CABINET AS REQUIRED A MAXIMUM OF 10 FEET FROM THE FIXTURE.
- C. CONNECT AIR TUBING (2) TO MOUNTED PUSHBUTTON ASSEMBLY (3) AND HAND TIGHTEN FERRULE NUT. CONNECT THE TAG END OF THE AIR TUBING (2) TO THE BRANCH BOX PRESSURE SWITCH 3/16" OD TUBE (4). AIR TUBING (2) FITS INSIDE THE PRESSURE SWITCH 3/16" OD TUBE (4).
- D. CONNECT RISER TUBING (5) TO VALVE ASSEMBLY AND FIXTURE DISCHARGE CONNECTOR. HAND TIGHTEN USING FERRULE NUTS PROVIDED.
- E. CONNECT STATION WIRE (6) TO BRANCH BOX AND APPROPRIATE LOCATION ON CONTROLLER.
- F. MAKE UP CONNECTIONS FROM TRANSFORMER (8) TO CONTROLLER AS SHOWN.
- G. AFTER THOROUGHLY FLUSHING SUPPLY LINES MAKE UP SUPPLY CONNECTIONS.

<p>ACORN ENGINEERING COMPANY P.O. BOX 3527 INDUSTRY, CA. 91744 (626) 336-4561 FAX (626) 961-2200</p>	<p>TITLE <b>EVS1 MASTER-TROL SINGLE TEMP VALVE INSTALLATION</b></p>		
	<p>MANUFACTURE DATE</p> <p><b>MAY 1998</b></p> <p><b>TO PRESENT</b></p>	<p>DATE ISSUED</p> <p><b>12/09/10</b></p>	<p>DRAWING NUMBER</p> <p><b>9905-330-004</b></p>
		<p>DATE REVISED</p>	



**MVC1-MA2 WIRING DIAGRAM SHOWN FOR REFERENCE ONLY**

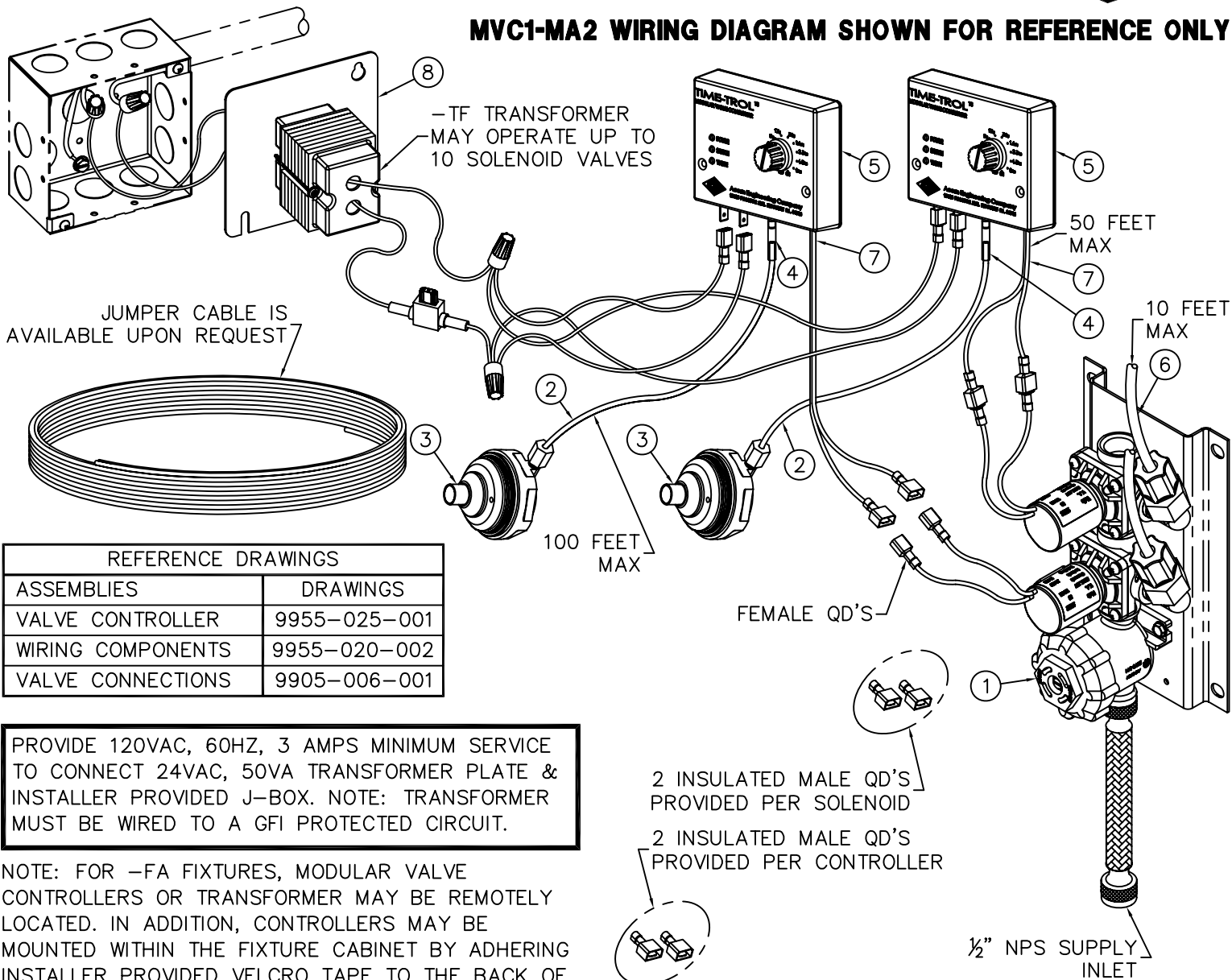

REFERENCE DRAWINGS	
ASSEMBLIES	DRAWINGS
VALVE CONTROLLER	9955-025-001
WIRING COMPONENTS	9955-020-002
VALVE CONNECTIONS	9905-006-001

PROVIDE 120VAC, 60HZ, 3 AMPS MINIMUM SERVICE TO CONNECT 24VAC, 50VA TRANSFORMER PLATE & INSTALLER PROVIDED J-BOX. NOTE: TRANSFORMER MUST BE WIRED TO A GFI PROTECTED CIRCUIT.

NOTE: FOR -FA FIXTURES, MODULAR VALVE CONTROLLERS OR TRANSFORMER MAY BE REMOTELY LOCATED. IN ADDITION, CONTROLLERS MAY BE MOUNTED WITHIN THE FIXTURE CABINET BY ADHERING INSTALLER PROVIDED VELCRO TAPE TO THE BACK OF THE CONTROLLER AND ONTO FIXTURE CABINET.

**INSTALLATION INSTRUCTIONS:**

- A- ROUGH-IN & INSTALL FIXTURE PER MANUFACTURER'S INSTRUCTIONS.
- B- MOUNT SOLENOID VALVE ASSEMBLY (1) WITHIN THE CHASE OR FIXTURE FRAME / CABINET AS REQUIRED A MAXIMUM OF 10 FEET FROM THE FIXTURE.
- C- CONNECT AIR TUBING (2) TO MOUNTED PUSHBUTTON ASSEMBLY (3) AND HAND TIGHTEN FERRULE NUT. CONNECT THE TAG END OF THE AIR TUBING (2) TO THE VALVE CONTROLLER TUBE (4) AT THE POSITION MARKED "ACTUATOR" ON THE CONTROLLER (5). AIR TUBING FITS INSIDE THE CONTROLLER TUBE (4).

- D- CONNECT RISER TUBING (6) TO VALVE ASSEMBLY AND FIXTURE DISCHARGE CONNECTOR. HAND TIGHTEN USING FERRULE NUTS PROVIDED.
- E- CONNECT CONTROLLER WIRES (7) (INDICATED AS "VALVE" ON THE CONTROLLER) FROM VALVE CONTROLLER (2) TO SOLENOID VALVE (1).

- F- MAKE UP CONNECTIONS FROM TRANSFORMER (8) TO CONTROLLERS IN PARALLEL AS SHOWN.
- G- AFTER THOROUGHLY FLUSHING SUPPLY LINES MAKE UP SUPPLY CONNECTIONS.
- H- SET TIMING ON VALVE CONTROLLER (5) TO DESIRED FLOW DURATION.

ACORN ENGINEERING COMPANY P.O. BOX 3527 INDUSTRY, CA. 91744 (626) 336-4561 FAX (626) 961-2200	TITLE <b>MVC1 TIME-TROL SINGLE TEMP VALVE INSTALLATION</b>		
	MANUFACTURE DATE <b>MAY 1990</b> <b>TO PRESENT</b>	DATE ISSUED <b>08/05/10</b>	DRAWING NUMBER <b>9900-001-004</b>



SIDE OUTLET SHOWN

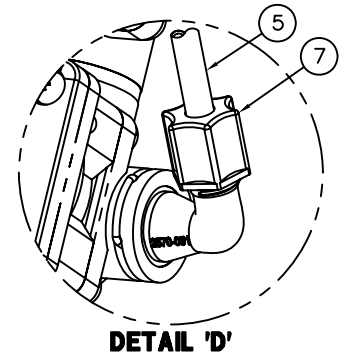
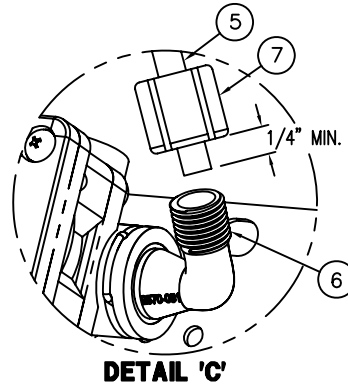
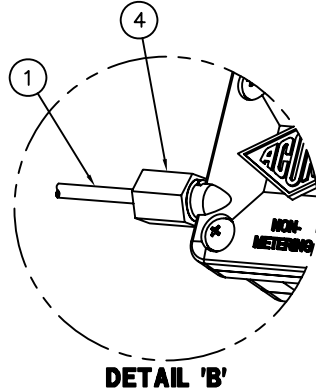
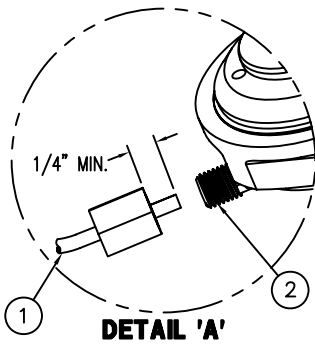

NOTE: PENAL-WARE & ECO-RAIN SHOWER FIXTURES USE 1/4" O.D. RISER TUBING WHILE OTHER SHOWER-WARE FIXTURES USE 3/8" O.D. TUBING.

AIR-CONTROL 03M-MA2 VALVE SHOWN FOR REFERENCE ONLY.

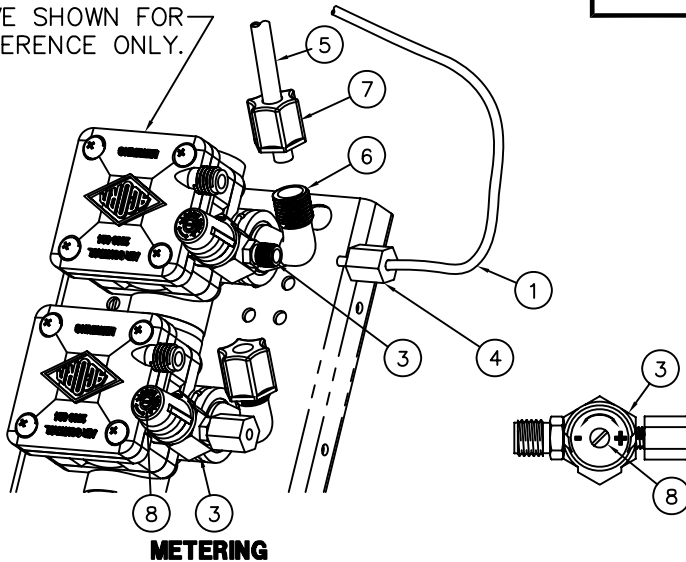

REFERENCE DRAWINGS	
REPAIR PARTS	DRAWING
VALVE BODY	9955-006-003
CHECKSTOP	9956-040-003
PUSHBUTTON/ESCUTCHEON	9957-300-001
METERING SERVOMOTOR	9955-000-003

NOTE:  
 • ALL TUBING SHOULD BE CUT SQUARE AND BE FREE OF BURRS OR DEFORMITIES TO ENSURE A WATER TIGHT CONNECTION.  
 • EXTEND TUBING AT LEAST 1/4" BEYOND FERRULE NUT AND INSERT TUBING INTO CONNECTION OPENING BEFORE TIGHTENING.  
 • TUBING SHOULD BE FREE OF KINKS TO ENSURE PROPER OPERATION.  
 • MAXIMUM RECOMMENDED WORKING WATER PRESSURE IS 100 PSI; TEMPERATURE IS 130° F; OUTLET TEMPERATURE IS RECOMMENDED AT A MAXIMUM OF 105° F.  
 WARNING:  
 PRIOR TO MAKING INSTALLATION, SUPPLY LINES MUST BE FLUSHED OF ALL FOREIGN MATERIAL SUCH AS PIPE DOPE, CHIPS, SOLDER, ETC. VALVE MUST BE DRAINED PRIOR TO BEING SUBJECTED TO FREEZING TEMPERATURES. MAXIMUM RECOMMENDED OUTLET WATER TEMPERATURE IS 105° F.

TIMING IS ADJUSTABLE FROM 5 TO 60 SECONDS AND IS ACCOMPLISHED BY ROTATING TIMING SCREW (8). TURNING THE TIMING SCREW CLOCKWISE INCREASES METERING TIME WHILE TURNING THE SCREW COUNTERCLOCKWISE DECREASES METERING TIME.

**INSTALLATION INSTRUCTIONS:**

- A- MOUNT FIXTURE IN ACCORDANCE TO MANUFACTURER'S INSTALLATION INSTRUCTIONS.
- B- ASSEMBLE PUSHBUTTONS AND OR SHOWER NOZZLES TO FIXTURE IF REQUIRED.
- C- CONNECT 1/8" O.D. POLYETHYLENE AIR LINE (1) TO PUSHBUTTON (2) AND VALVE TIMER ASSEMBLY (3). SEE DETAILS 'A' & 'B'. HAND TIGHTEN FERRULE NUT (4) PROVIDED.

- D- CONNECT SHOWER RISER (5) TO VALVE ASSEMBLY ELBOW (6). SEE DETAIL 'C' AND 'D'. HAND TIGHTEN FERRULE NUT (7) PROVIDED.
- E- AFTER THOROUGHLY FLUSHING SUPPLY LINES, MAKE UP CONNECTIONS TO VALVE ASSEMBLY INLET(S) 1/2" NPT OR 1/2" NPS FLEX HOSE AS REQUIRED.

ACORN ENGINEERING COMPANY  
 P.O. BOX 3527 INDUSTRY, CA. 91744  
 (626) 336-4561 FAX (626) 961-2200

TITLE <b>HAND OPERATED, AIR-CONTROL VALVE SHOWER CONNECTIONS</b>		
MANUFACTURE DATE	DATE ISSUED	DRAWING NUMBER
<b>OCTOBER 2010</b>	<b>10/28/10</b>	<b>9900-006-003</b>
<b>TO PRESENT</b>	DATE REVISED	



**TWO STATION AND ADA WIRING DIAGRAM SHOWN**

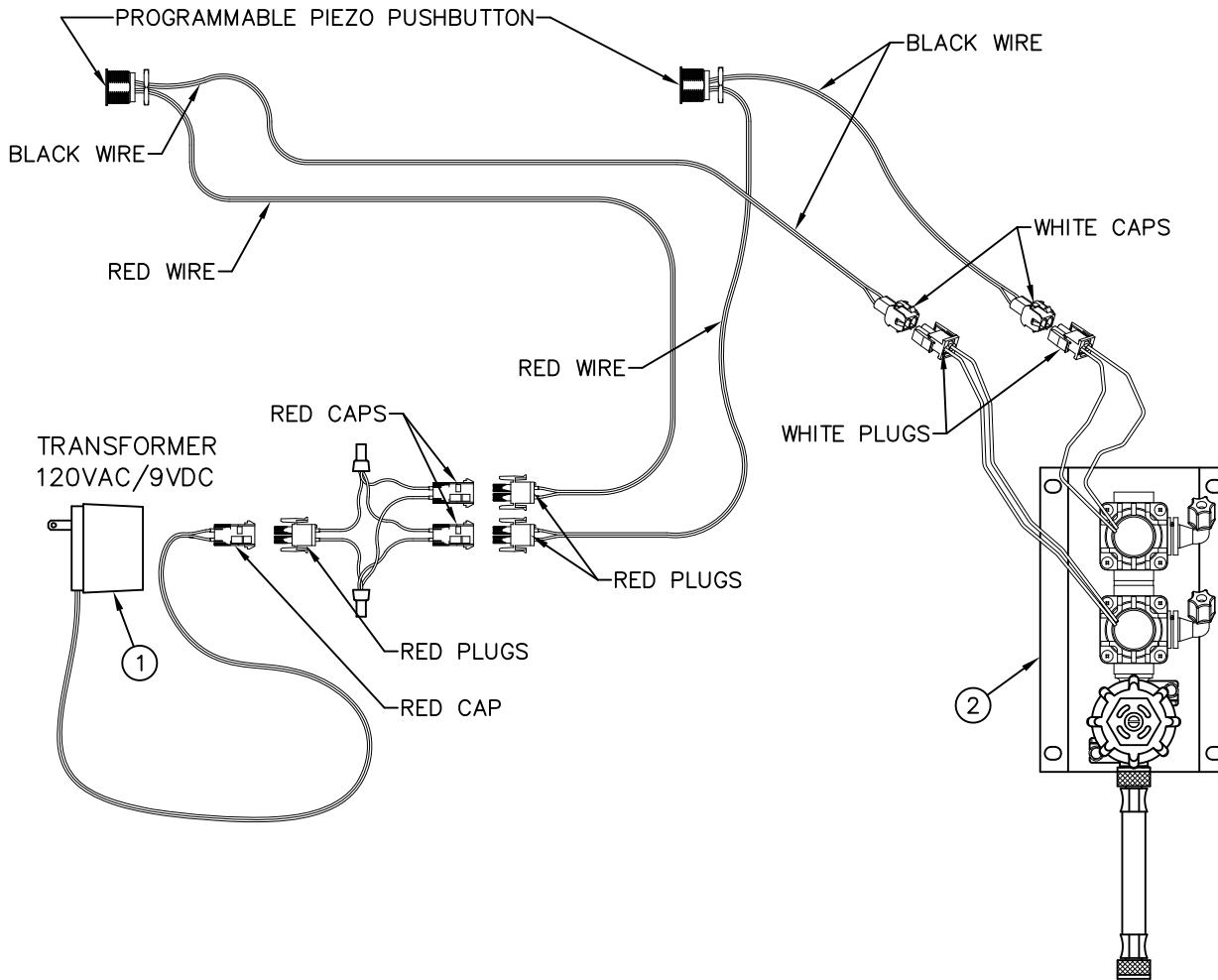

REFERENCE DRAWINGS	
9VDC SENSOR & PARTS	9955-019-002
PIEZO PB PROGRAMMING	9940-009-001

**INSTALLATION INSTRUCTIONS:**

A- USING APPROPRIATE INSTALLATION INSTRUCTIONS, MOUNT FIXTURE TO WALL AND MAKE-UP SUPPLY CONNECTIONS. ELECTRONIC PUSHBUTTON ARE FACTORY INSTALLED. POWER SUPPLY ① AND VALVE ② SHIPPED LOOSE.

B- INSTALL SOLENOID VALVE ASSEMBLY ② ON THE WALL (FASTENERS AND WALL ANCHORS BY OTHERS), MAKING SURE THAT THE VALVE WILL BE WITHIN HOUSING OR BLOCKOUT AREA.

C- CONNECT WATER SUPPLY (AFTER FLUSHING LINES) TO VALVE, AND VALVE RISER TO SHOWERHEAD AS PER UNIT INSTALLATION INSTRUCTIONS.

D- CONNECT SOLENOID VALVE, POWER SUPPLY AND SENSOR WIRING AS SHOWN ON DETAIL.

E- COMPLETE THE INSTALLATION OF THE UNIT ACCORDING ACORDING TO THE UNITS INSTALLATION INSTRUCTIONS.

**NOTE:**

1- PLUG-IN TRANSFORMER INCLUDES BUILT-IN SECONDARY FUSE. IN THE EVENT OF POWER SURGE TRANSFORMER MAY REQUIRE REPLACEMENT.

2- ELECTRICAL RECEPTACLE MUST BE WIRED TO A GFI PROTECTED CIRCUIT. FIXTURE MUST BE EARTH GROUNDED PER N.E.C. (NATIONAL ELECTRICAL CODE).



ACORN ENGINEERING COMPANY  
P.O. BOX 3527 Industry, CA 91744  
15125 Proctor Ave Industry, CA 91746  
(626) 336-4561 FAX (626) 961-2200

TITLE <b>-PPZ PIEZO ELECTRONIC PUSHBUTTON INSTALLATION</b>		
MANUFACTURE DATE <b>OCTOBER 2013 TO PRESENT</b>	DATE ISSUED <b>10/11/13</b>	DRAWING NUMBER <b>9927-223-001</b>
	DATE REVISED	



## Programable Piezo Pushbutton Programming Instructions (Flow Time Adjustment)

The Button is factory set an 8 sec. timing cycle, if an 8 sec. cycle is adequate, then **no** programming adjustment is required.



**NOTE:** Read the entire document before trying to program the piezo pushbutton.

### THE TIME SETTINGS PROGRAM USES 3 DIFFERENT TIMING MODES:

- **1 second timing mode:** Each push of the button adds 1 second to the total timing cycle.
- **5 second timing mode:** Each push of the button adds 5 seconds to the total timing cycle.
- **20 second timing mode:** Each push of the button adds 20 seconds to the total timing cycle.

To program the piezo pushbutton, you will need to be able to see the back of the piezo pushbutton.

Prevision must be made to access the back of the piezo pushbutton. There is an LED on the back of the piezo pushbutton under a layer of transparent epoxy, used as a programming indicator light.



**NOTE:** This programming procedure moves along rapidly, there is only about 2 or 3 seconds between programming operations.

In order to start the programming the piezo pushbutton, the button must be powered down. Disconnect the red power cable and wait 20 seconds, then reconnect the red power cable.

As soon as the cable is reconnected the LED will start flashing, it will flash 4 times, then stays on for 3 seconds. During the 3 second period, push the piezo button once, the LED will go out, now you are in the **1 sec timing mode** and each time the button is pushed the LED will flash, adding 1 sec to the total timing cycle.

To move on to the **5 sec timing mode**, pause and wait for the LED to flash 2 times, now you are in the 5 sec timing mode. Each time the button is pushed the LED will flash, adding 5 sec to the total timing cycle.

To move on to the **20 sec timing mode**, pause and wait for the LED to flash 3 times, now you are in the 20 sec timing mode and each time the button is pushed the LED will flash, adding 20 sec to the total timing cycle. After programing is complete, pause and wait for the LED to flash 4 times and then 5 times, which completes the programming.

- When a **timing mode is not required** then **do not** push the button and wait for the next timing mode.
- Each timing mode (1 sec, 5 sec or 20 sec timing mode) can be sequenced up to 100 times, that is the number of times, the button can be pushed, to increase the total timing cycle in each timing mode.



Please visit [www.acorneng.com](http://www.acorneng.com) for most current specifications.

# Programmable Piezo Pushbutton Programming Instructions (Flow Time Adjustment)

## WORKSHEET

**(FILL IN ALL BOXES, WHICH WILL SIMPLIFY THE PROGRAMMING PROCEDURE)**

Fill in all the Boxes below  
↓ ↓

Determine the number of seconds per timing cycle

1 Push = 1 Second  
 x 1 =  sec

- PROGRAMING STEPS:**
- Power down piezo button for 10 seconds.
  - Reconnect power.
  - LED flashes, then stay on.
  - While the LED is steady on, push button.
  - LED turns off.
- ↔
- You are in the 1 sec timing mode, immediately push the button, 1 push equals 1 sec added to the total timing cycle.
  - Pause and wait for the LED to flash 2 times.

**ADD** ↑ ↓

1 Push = 5 Seconds  
 x 5 =  sec

- ↔
- You are in the 5 sec timing mode, immediately push the button, 1 push equals 5 sec added to the total timing cycle.
  - Pause and wait for the LED to flash 3 times.

**ADD** ↑ ↓

1 Push = 20 Seconds  
 x 20 =  sec

- ↔
- You are in the 20 sec timing mode, immediately push the button, 1 push equals 20 sec added to the total timing cycle.

**EQUALS** ↓

Total timing cycle equals  
 seconds





# INSTALLATION, OPERATIONS & MAINTENANCE MANUAL

Please visit [www.acorneng.com](http://www.acorneng.com) for most current specifications.

