



Dura-Ware® 2158 Series

ADA Compliant High Efficiency Urinal



2158-T-1

Fixture May Show Some Available Options

Please visit www.acorneng.com for most current specifications.

ADA Compliant High Efficiency Urinal

Dura-Ware High Efficiency Urinals are engineered to combine attractive looks with versatility, and intended for mounting onto a finished wall from the front. Units feature a contoured interior to facilitate cleaning. Urinals mounted at 17" rim height comply with ANSI, ADA, UFAS accessibility requirements. Compliance is subject to the interpretation and requirements of the local code authority.

Fixture bowl is fabricated of 16 gage type 304 stainless steel and the housing fabricated of 18 gage type 304 stainless steel with exterior surfaces polished to a satin finish.

Urinal is a high efficiency type requiring a 1/8 GPF (0.47 Liters per Flush) to 1/2 GPF (1.8 Liters per Flush) flush valve and supplied with 3/4" NPT flushing inlet connection and stainless steel bee hive dome strainer with 1-1/2" O.D. P-Trap assembly.

Installation is Front Mount and the fixture includes an open bottom to facilitate mounting directly to a reinforced wall from within the housing.

GUIDE SPECIFICATION

Provide Acorn Dura-Ware Stainless Steel Urinal (specify model number and options). Urinal mounted at 17" rim height to comply with ANSI, ADA and UFAS accessibility requirements. Interior to have a contoured surface to facilitate cleaning. Fixture shall be fabricated of 18 gage with 16 gage bowl type 304 stainless steel with exposed surfaces polished to a satin finish.



Dura-Ware® 2158: Dura-Ware Urinal - ADA Compliant

MODEL NUMBER AND OPTIONS SELECTION

WALL THICKNESS AND TYPE

Thickness: _____ Type: Concrete Block Steel

BASE MODEL NUMBER

-2158 Dura-Ware Urinal

SUPPLY SELECTION (Must Specify)

-T Top (Exposed)
 -W Wall (Concealed)

FIXTURE MOUNTING & WASTE (Must Specify)

-1 Off-Floor, Wall Outlet

FLUSH VALVE GPF's (Must Specify)

-0.125 GPF
 -0.5 GPF

FLUSH VALVE OPTIONS (Must Specify)

Refer to Acorn Dura-Ware Supplementary for Box Cover(s) and Access Panel(s)

-FV Flush Valve, Mechanical (N/A for ADA)
 -FVBO Flush Valve By Others
 -FVH Flush Valve Hydraulic (Concealed F.V.)
 -FVL Flush Valve, ADA Lever Handle (Concealed F.V.)

PRODUCT OPTIONS (Must Specify)

-EG Enviro-Glaze (Interior and Exterior):
 Color: _____
 -HP High Polish Finish

Please visit www.acorneng.com for most current specifications.

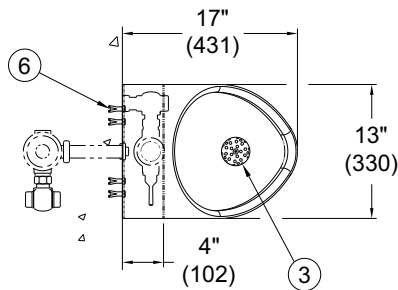

1. Flush Nozzle
2. 1-1/2" O.D. P-Trap Assembly
3. Removable Strainer Assembly
4. Optional -T Top Supply -FV Flush Valve
5. Optional -W Wall Supply -FV Flush Valve
6. Wall Mounting Anchor (By Others)
7. 3/4" NPT Flushing Inlet Connection

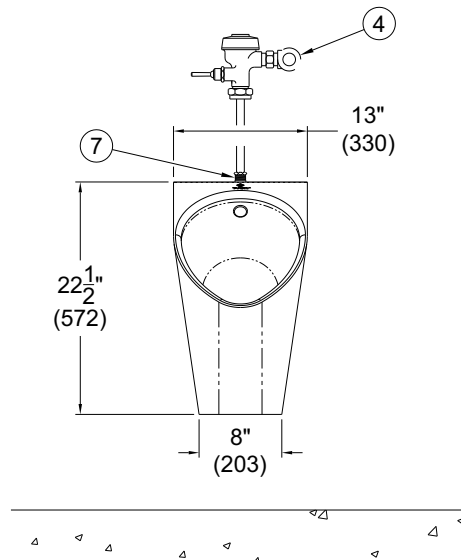
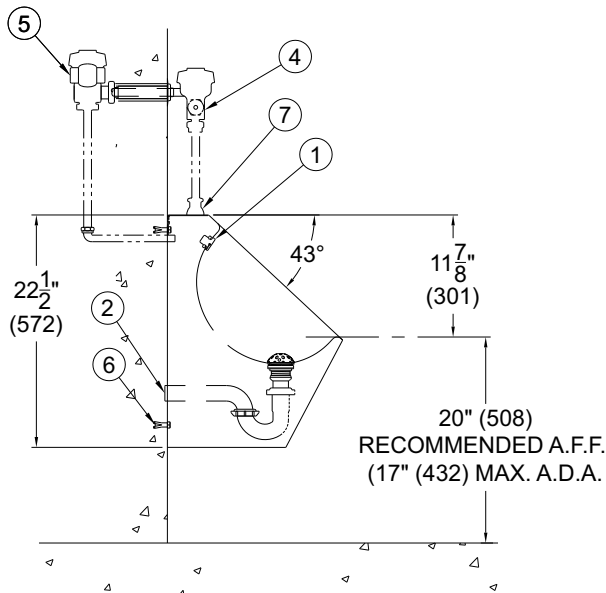

MODEL #2158-T/W-1

WARNING: Cancer and Reproductive Harm - www.P65Warnings.ca.gov

Important: Installation instructions and current rough-in are furnished with each fixture. Do not rough in without certified dimensions. <small>Dimensions are subject to manufacturer's tolerance of plus or minus 1/4" and change without notice. Acorn assumes no responsibility for use of void or superseded data. © Copyright 2008 Acorn Engineering Company</small>	
<p style="text-align: center;">Selection Summary</p> <p>Model No. & Option _____</p> <p>Quantity _____</p>	<p style="text-align: center;">Approved for Manufacturing</p> <p>Company _____ Title _____</p> <p>Signature _____ Date _____</p>