

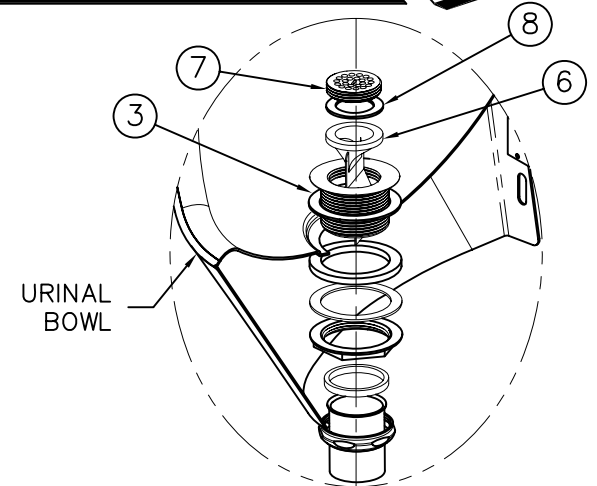

REFERENCE DRAWING	
TAILPIECE ASSEMBLY	9985-101-001

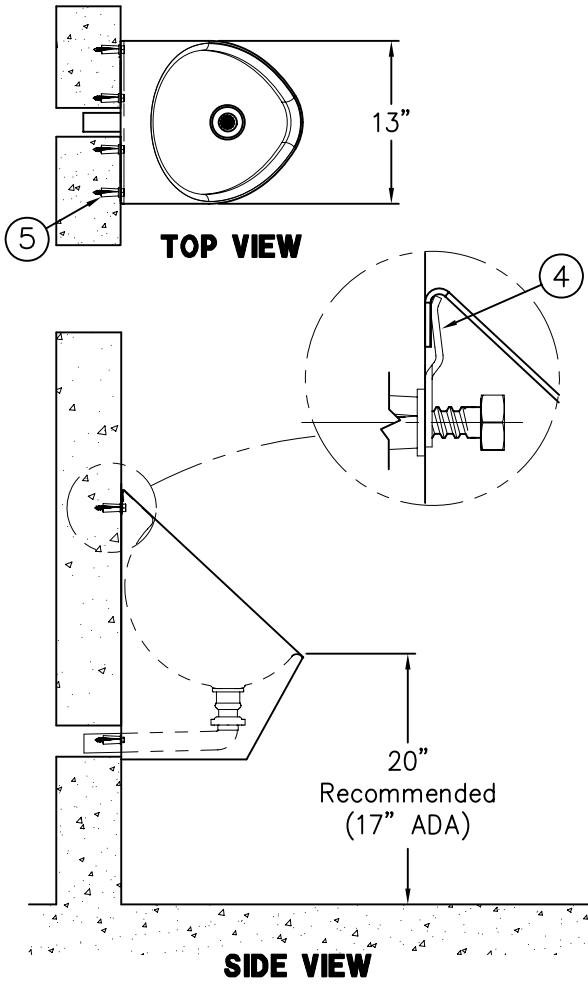

**Tailpiece Assembly**

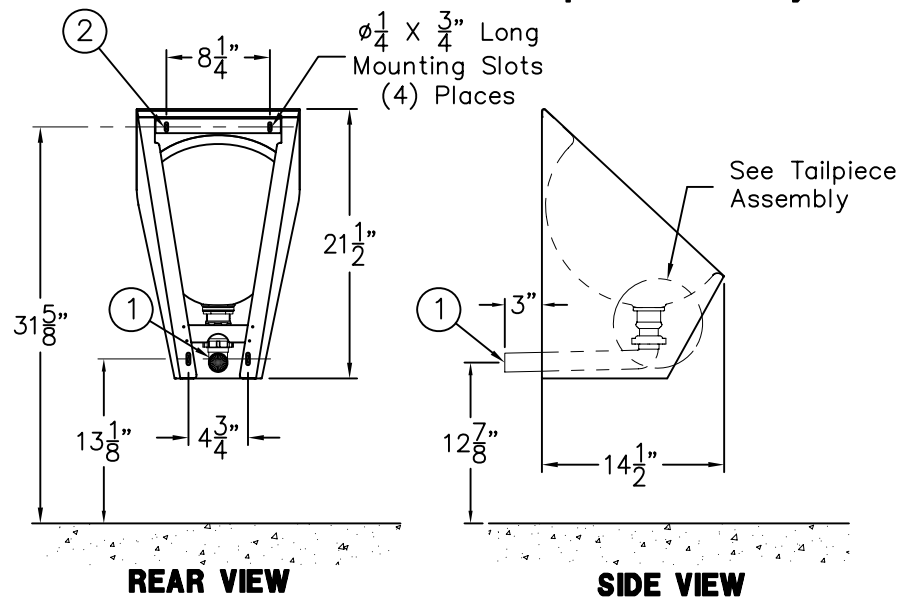

**INSTALLATION INSTRUCTIONS:**

- A- ROUGH-IN FOR THE FOLLOWING:
  - WASTE OUTLET 1-1/2" SLIP JOINT (1).
  - MOUNTING POINTS (2) AS SHOWN FOR ANCHORING HARDWARE BY OTHERS.
- B- PLACE DRAIN GASKET (3) OVER DRAIN OPENING AND ASSEMBLE TAILPIECE TO FIXTURE AS SHOWN. CONNECT 1-1/2" SLIP JOINT WASTE ARM (1) TO TAILPIECE ASSEMBLY.
- C- ANCHOR S-CLIP (4) TO WALL WITH ANCHORING HARDWARE BY OTHERS (5). PLACE URINAL ABOVE S-CLIP AND AGAINST WALL, SLIDE HOUSING DOWN TO ENGAGE S-CLIP WHILE INSERTING SLIP JOINT WASTE CONNECTION. FASTEN LOWER REMAINING ANCHORING POINTS.
- D- MAKE UP WASTE CONNECTION.

- E- WHEN INSTALLING OR REPLACING DUCK BILL DIAPHRAGM (6) REMOVE DRAIN CHECK RETAINER (7) AND FRICTION WASHER (8) WITH 3/16" FLAT TIP SCREWDRIVER.
- F- REPLACE DUCKBILL DIAPHRAGM (6) IN TAILPIECE ASSEMBLY.
- G- REINSTALL FRICTION WASHER (8) AND DRAIN CHECK RETAINER (7).

NOTES: FOR SUFFIX OPTION -ADA URINAL RIM HEIGHT BECOMES 17" AFF MAXIMUM. REFER TO ADA ACCESSIBILITY GUIDELINES FOR COMPLETE INSTALLATION REQUIREMENTS.

ACORN ENGINEERING COMPANY P.O. BOX 3527 INDUSTRY, CA. 91744 (626) 336-4561 FAX (626) 961-2200	TITLE <b>WATERLESS URINAL, #2159</b>		
	MANUFACTURE DATE <b>SEPTEMBER 2008</b> <b>TO PRESENT</b>	DATE ISSUED <b>10/14/08</b>	DRAWING NUMBER <b>9908-303-001</b>
		DATE REVISED <b>03/04/09</b>	



# MAINTENANCE MANUAL

## DURA-WARE MODEL 2159

### WATERLESS URINAL

What are the benefits of installing the Acorn Engineering Company's, Dura-Ware Waterless Urinal?

#### ◆ Cost Savings

With no supply to rough for, no flush valve, no flush control hardware to provide, these fixtures represent a substantial savings in addition to the annual savings resulting from not having to use water every time the unit is used. The absence of a flushing mechanism eliminates valve repairs and reduces the opportunities for vandalism; additionally, overflows due to clogged drains are not a problem because large amounts of water are not being used. Because our Waterless urinal requires no special cartridges to replace or liquids to maintain, supply and maintenance costs remain low.

#### ◆ Environmentally Friendly

Acorn's Waterless Urinals have a positive impact on the environment because they consume no water to operate, thus wastewater requiring treatment is not generated and the use of special fluids or chemicals is not required.

#### ◆ Reduced Odors

The Waterless Urinal uses a one-way duckbill that provides a physical barrier between the user and the plumbing system preventing odors from going back into the facility. With proper maintenance and daily cleaning the absence of a water-urine dilution in the bowl will lesson the prevalence of odors often associated with urinals.

#### ◆ Cleaning & Maintenance

The Waterless Urinal should be cleaned daily using mild soap and water, rinsed with clean water and dried with a soft cloth to ensure odorless operation.

Chemical cleaners should not be used damage to the diaphragm may result. The silicone duckbill diaphragm will provide long lasting service from 6 to 12 months depending on frequency of usage and maintenance performed.

#### ◆ Daily Cleaning Procedures

- Wear gloves (and goggles) as you would to clean any restroom fixture.
- Remove any foreign objects found inside the bowl.
- Clean fixture bowl inside area and outside housing with mild soap and water.
- Rinse with clean water. Pour a mild solution of detergent and water into the fixture allowing water to dissipate through the drain. The solution should be composed of about a gallon of water and 1/4 cup of detergent. This will reduce the possibility of encrustation build up that may result in blocked pipes.

#### ◆ One-Way Valve Replacement

- The Waterless Urinal uses a one-way valve consisting of a silicone duckbill diaphragm that provides a physical barrier between the user and the plumbing system. The duckbill diaphragm may be replaced by:
  - Remove the grid strainer using a standard 1/4" flat tip screwdriver. Fit the blade in the slot on the top of the strainer and turn counterclockwise to remove.
  - Remove the washer and duckbill diaphragm.
  - Replace the silicone duckbill diaphragm and reinstall the washer
  - Reinstall the grid strainer using the screwdriver.

#### WARNING!

NEVER use chlorine, iodine or fluoride or other chemical dilutions to clean the Waterless Urinal. Avoid dumping oil or grease into the basin. Remove grid strainer, washer and silicone duckbill diaphragm before using drain cleaners. Flush with water before reinstalling diaphragm, washer and strainer. Failure to follow these guidelines may result in early wear and deterioration of the one-way valve.

Waterless urinals should NOT be used on copper drain lines which can react to the urine and cause pitting and corrosion.

#### ACORN ENGINEERING COMPANY

P.O. BOX 3527 • CITY OF INDUSTRY, CA 91744 U.S.A.  
TOLL FREE 800-488-8999 :: LOCAL 626-336-4561  
FAX 626-961-2200 :: [www.acorneng.com](http://www.acorneng.com)



Please visit [www.acorneng.com](http://www.acorneng.com)  
for most current specifications.

## MAINTENANCE MANUAL

### DURA-WARE 2159



# ACORN ENGINEERING COMPANY

Manufacturers of Engineered Plumbing Products

#### MAIL ADDRESS

P.O. BOX 3527  
CITY OF INDUSTRY, CA 91744 U.S.A.

#### PHYSICAL ADDRESS

15125 PROCTOR AVENUE  
CITY OF INDUSTRY, CA 91746 U.S.A.

**TOLL FREE** 800-488-8999 • **LOCAL** 626-336-4561  
**FAX** 626-961-2200 • **WEB** [www.acorneng.com](http://www.acorneng.com)

---

## WARRANTY INFORMATION

Acorn warrants that all of its products are guaranteed against defective material or poor workmanship for a period of one year from date of shipment. Acorn's liability under this warranty shall be discharged by replacing without charge F.O.B. City of Industry, California, any goods, or part thereof, which appears to the company upon inspection to be of defective material or not of first class workmanship, provided that claim is made in writing to the company within reasonable period after receipt of the product. Where claims for defects are made, the defective part or parts shall be delivered to the company, prepaid, at City of Industry, California for inspection. Acorn will not be liable for the cost of repairs, alterations or replacement, or for any expense connected therewith made by the owner or his agents, except upon written authority from the Acorn City of Industry office. Acorn will not be liable for any damages caused by defective materials or poor workmanship, except for replacements, as above provided. Contact local Acorn Representative for complete terms and conditions.