

ROUGH-IN FOR THE FOLLOWING:

- 1- LAVY WASTE OUTLET – 1-1/2" O.D. TUBE FOR COMPRESSION JOINT.
- 2- MIXING VALVE INLET – 1/2" NPS HOT AND COLD VALVE SUPPLIES.
- 3- MOUNTING LOCATIONS – 9/16" DIAMETER MOUNTING HOLES (8) PLACES, 9/16" x 1-1/8" SLOTS (8) PLACES.
- 4- BACKSPASH MOUNTING – (4) "S" TYPE MOUNTING CLIPS. CLIPS HAVE (2) 9/32" x 3/4" SLOTS FOR FASTENERS.
- 5- TRAP COVER MOUNTING – (6) MOUNTING BRACKETS. EACH BRACKET HAS (2) 3/8" x 9/16" SLOTS FOR FASTENERS.
- 6- FOR –SO SENSOR OPERATED CONTROLS. PROVIDE 120V/60Hz/3 AMPS(MAX.) ELECTRIC RECEPTACLE TO CONNECT FACTORY SUPPLIED 120 VAC TO 9VDC 100 mA PLUG-IN TRANSFORMER. NOTE: RECEPTACLE MUST BE WIRED TO A GFI PROTECTED CIRCUIT. FIXTURE MUST BE EARTH GROUNDED PER N.E.C. (NATIONAL ELECTRICAL CODE).

INSTALLATION INSTRUCTIONS:

SOME AVAILABLE OPTIONS FOR THIS UNIT MAY ALTER THESE ROUGH-IN INSTRUCTIONS. CONTACT FACTORY FOR DETAILS. UNIT IS INTENDED FOR INSTALLATION ON A FINISHED WALL WITH APPROPRIATE WALL BACKING. 3/8" UNC WALL

ANCHORS AND MOUNTING HARDWARE ARE NOT INCLUDED. UNIT INCLUDES WASTE PIPING AND 1-1/2" TUBULAR P-TRAP. VALVE ASSEMBLY IS SHIPPED LOOSE FOR MOUNTING TO WALL. INCLUDES VALVE AND TRAP ENCLOSURE, SHIPPED LOOSE.

<p>ACORN ENGINEERING COMPANY P.O. BOX 3527 Industry, CA 91744 15125 Proctor Ave Industry, CA 91746 (626) 336-4561 FAX (626) 961-2200</p>	<p>TITLE CURVED FRONT STN. STL. ROUGH-IN MODEL # 3704-1-EB (ENCLOSED BOTTOM)</p>	
	<p>MANUFACTURE DATE DECEMBER 1997 TO PRESENT</p>	<p>DATE ISSUED 12/29/97</p> <p>DATE REVISED 01/10/19 D</p>

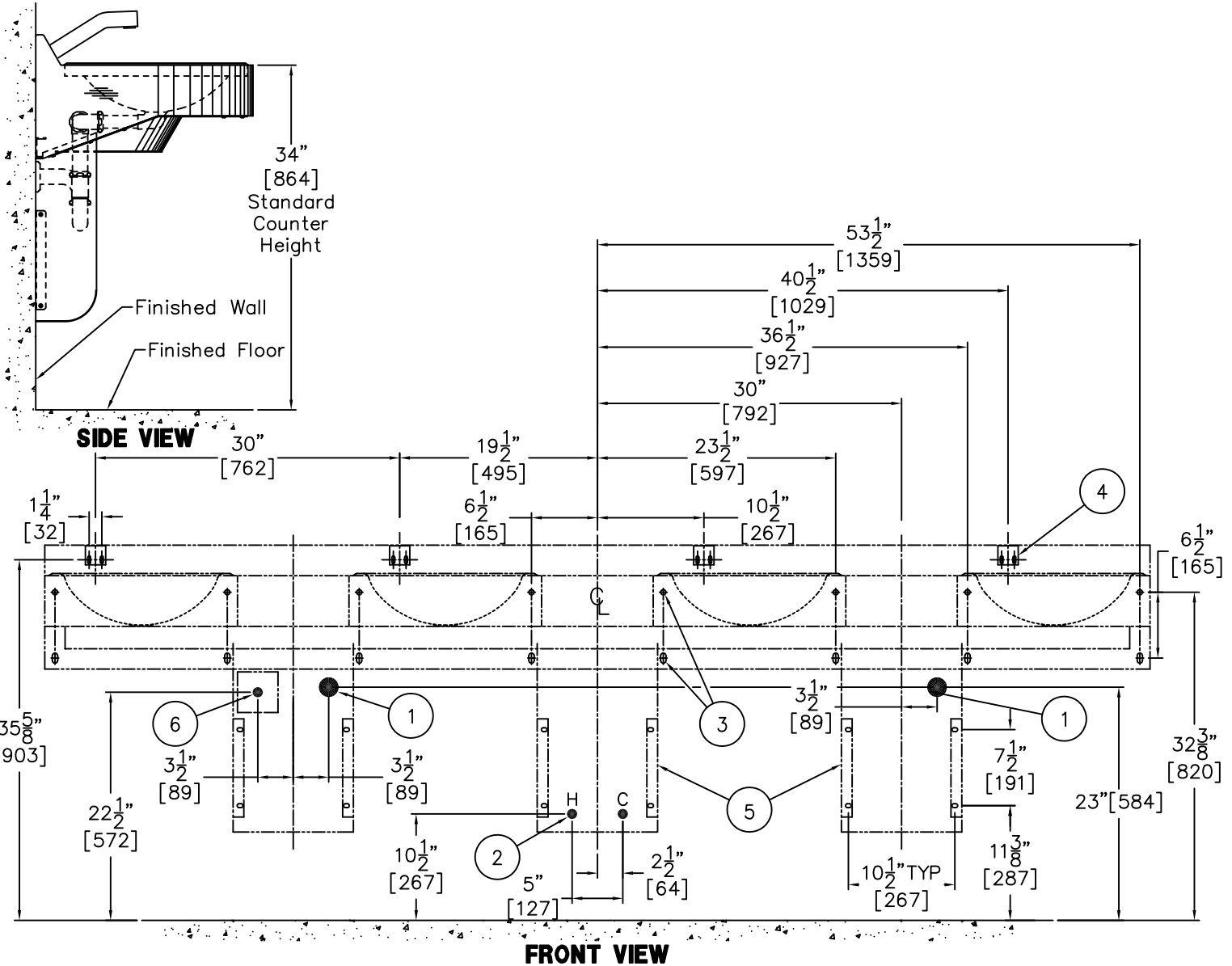

ROUGH-IN FOR THE FOLLOWING:

- 1- LAVY WASTE OUTLET – 1-1/2" O.D. TUBE FOR COMPRESSION JOINT.
- 2- MIXING VALVE INLET – 1/2" NPS HOT AND COLD VALVE SUPPLIES.
- 3- MOUNTING LOCATIONS – 9/16" DIAMETER MOUNTING HOLES (8) PLACES, 9/16" x 1-1/8" SLOTS (8) PLACES.
- 4- BACKSPASH MOUNTING – (4) "S" TYPE MOUNTING CLIPS. CLIPS HAVE (2) 9/32" x 3/4" SLOTS FOR FASTENERS.
- 5- TRAP COVER MOUNTING – (6) MOUNTING BRACKETS. EACH BRACKET HAS (2) 3/8" x 9/16" SLOTS FOR FASTENERS.
- 6- FOR -SO SENSOR OPERATED CONTROLS. PROVIDE 120V/60Hz/3 AMPS(MAX.) ELECTRIC RECEPTACLE TO CONNECT FACTORY SUPPLIED 120 VAC TO 9VDC 100 mA PLUG-IN TRANSFORMER. NOTE: RECEPTACLE MUST BE WIRED TO A GFI PROTECTED CIRCUIT. FIXTURE MUST BE EARTH GROUNDED PER N.E.C. (NATIONAL ELECTRICAL CODE).

INSTALLATION INSTRUCTIONS:

SOME AVAILABLE OPTIONS FOR THIS UNIT MAY ALTER THESE ROUGH-IN INSTRUCTIONS. CONTACT FACTORY FOR DETAILS. UNIT IS INTENDED FOR INSTALLATION ON A FINISHED WALL WITH APPROPRIATE WALL BACKING. 3/8" UNC WALL

ANCHORS AND MOUNTING HARDWARE ARE NOT INCLUDED. UNIT INCLUDES WASTE PIPING AND 1-1/2" TUBULAR P-TRAP. VALVE ASSEMBLY IS SHIPPED LOOSE FOR MOUNTING TO WALL. INCLUDES VALVE AND TRAP ENCLOSURE, SHIPPED LOOSE.

<p>ACORN ENGINEERING COMPANY P.O. BOX 3527 Industry, CA 91744 15125 Proctor Ave Industry, CA 91746 (626) 336-4561 FAX (626) 961-2200</p>	<p>TITLE CURVED FRONT STN. STL. ROUGH-IN MODEL # 3704-1-EB (ENCLOSED BOTTOM)</p>	
	<p>MANUFACTURE DATE DECEMBER 1997 TO PRESENT</p>	<p>DATE ISSUED 12/29/97</p> <p>DATE REVISED 01/10/19 D</p>

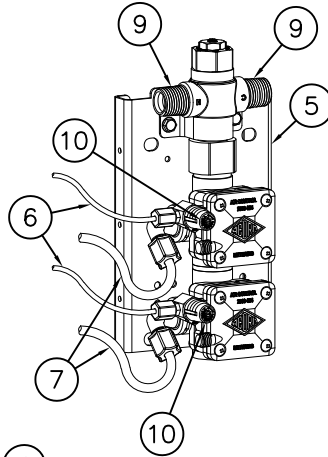
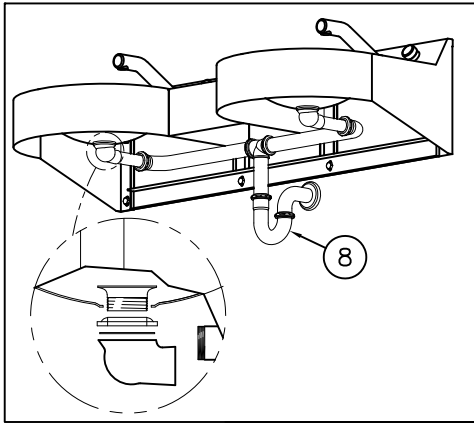

REFERENCE DRAWINGS	
SPOUT INSTALLATION	9927-200-001
-SO SENSOR OP. INSTALLATION	9927-221-005
-H PUSHBUTTON PARTS	9957-700-001
-H VALVE MAINTENANCE	9940-005-002
-H SERVOMOTOR	9955-000-003
CHECKSTOP/STRAINER	9956-040-003
WASTE PIPING	9985-354-001
MISCELLANEOUS HARDWARE	9951-005-001
MXTP VALVE TEMP ADJUST	9912-252-002
OPTIONAL -PDM SOAP DISPENSER	9927-210-003

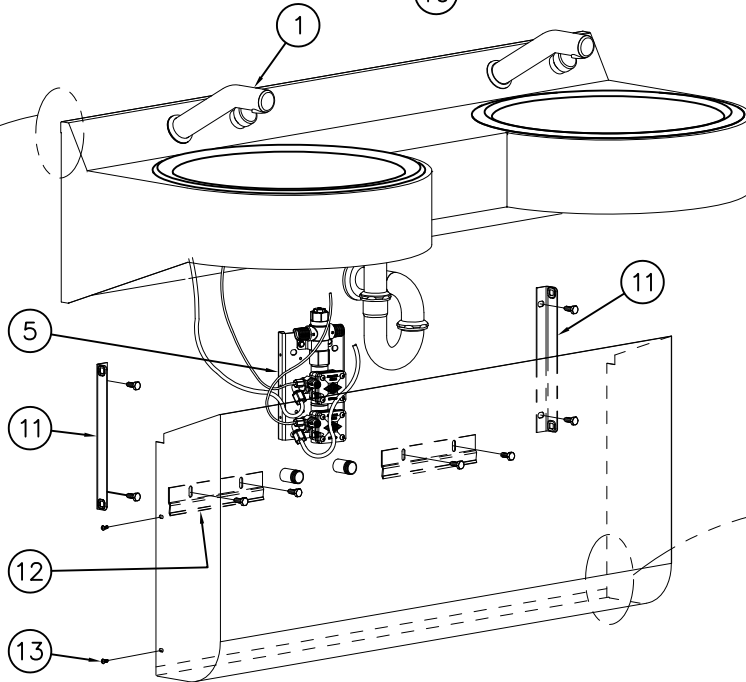
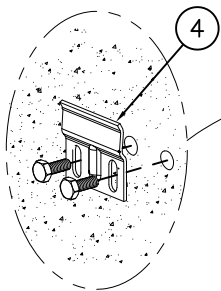

3712 MODEL SHOWN FOR REFERENCE ONLY

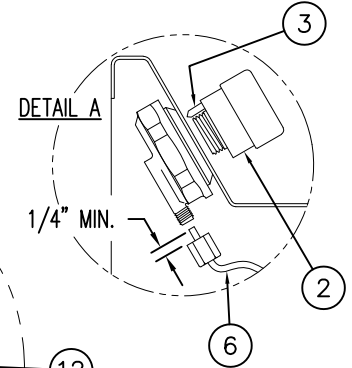

INSTALLATION INSTRUCTIONS:

NOTE: SOME AVAILABLE OPTIONS MAY AFFECT INSTALLATION. REFER TO ALL INSTALLATION SHEETS FOR SPECIFIED OPTIONS BEFORE PROCEEDING.

- A- PROVIDE REQUIRED ROUGH-INS AND INSTAL WASHBASIN SUPPORT FRAME AS DETAILED ON APPROPRIATE DRAWINGS.
- B- INSTALL SPOUTS (1) AND PUSHBUTTONS (2) TO FIXTURE. ALIGN ANTI-ROTATION PIN (3) WITH SPOUT PUNCHING SLOT BEFORE TIGHTENING. SEE DETAIL 'A'.
- C- ANCHOR S-CIPS (4) TO WALL AND POSITION FIXTURE BACKSPASH OVER JOGGLE ON S-CLIPS.
- D- ANCHOR VALVE (5) TO WALL WHERE NOTED ON ROUGH-IN SHEET. CONNECT 1/8" O.D. AIR LINES (6) TO PUSHBUTTONS (2) AND TO AIR-CONTROL VALVE ASSEMBLY (5) BY HAND TIGHTENING THE FERRULE NUTS PROVIDED. SEE DETAIL 'A'. CONNECT 1/4" O.D. WATERLINES (7) FROM SPOUTS (1) TO VALVE (5) & WATERTIGHT WITH FERRULE NUTS PROVIDED.

NOTE:

MAXIMUM RECOMMENDED WORKING WATER PRESSURE IS 100 PSI; TEMPERATURE IS 130°F; OUTLET TEMPERATURE IS RECOMMENDED AT A MAXIMUM OF 105°F. PRIOR TO MAKING INSTALLATION, SUPPLY LINES MUST BE FLUSHED OF ALL FOREIGN MATERIAL SUCH AS PIPE DOPE, CHIPS, ETC. VALVE MUST BE DRAINED PRIOR TO BEING SUBJECTED TO FREEZING TEMPERATURES.

- E- ASSEMBLE WASTE PIPING (8) PROVIDED AND MAKE UP LAVY WASTE CONNECTION (1-1/2" O.D. COMPRESSION). SEE APPROPRIATE REFERENCE DRAWING FOR PARTS.
- F- AFTER THOROUGHLY FLUSHING SUPPLY LINES, MAKE UP CONNECTIONS FROM 1/2" NPT VALVE INLETS (9) TO SUPPLY STUB OUTS. CONNECTOR HOSES AND SUPPLY STUB OUTS PROVIDED BY THE INSTALLER.
- G- TURN ON WATER SUPPLY. CHECK FOR LEAKS ON VALVE (5) & ADJUST TIMERS (10) TO OBTAIN DESIRED CYCLE DURATION.
- H- ANCHOR "L" BRACKETS (11) AND S-CLIP BRACKETS (12) TO WALL. MOUNT TRAP ENCLOSURE TO BRACKETS WITH VANDAL RESISTANT FASTENERS (13) PROVIDED.



ACORN ENGINEERING COMPANY
P.O. BOX 3527 Industry, CA 91744
15125 Proctor Ave Industry, CA 91746
(626) 336-4561 FAX (626) 961-2200

TITLE STAINLESS STEEL MULTI-BASIN - MODEL #3701-1, 3702-1, 3703-1, 3704-1		
MANUFACTURE DATE	DATE ISSUED	DRAWING NUMBER
OCTOBER 2009 TO PRESENT	01/04/10	9927-110-002
	DATE REVISED 12/28/18 B	

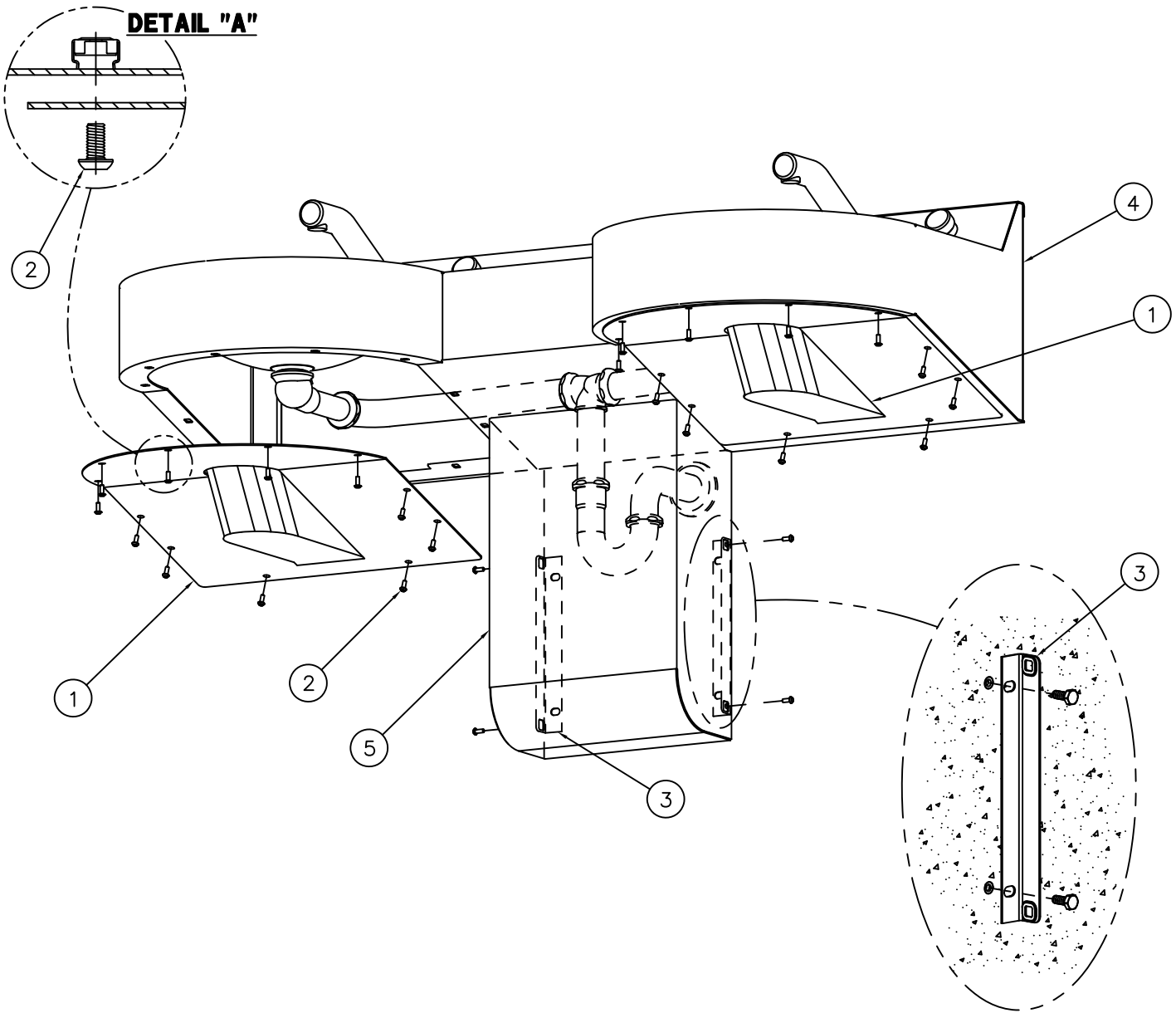

INSTALLATION INSTRUCTIONS:

A- REMOVE BOTTOM ENCLOSURES ① BY UNSCREWING BUTTON HEAD SCREWS ②. SEE DETAIL "A".

B- REFERENCE DRAWING #9927-110-002 FOR WASHBASIN ④ MOUNTING AND CONNECTIONS.

C- ANCHOR BRACKETS ③ TO WALL. FASTENERS AND ANCHORS BY OTHERS.

D- ASSEMBLE -EB ENCLOSED BOTTOM:

3701/3703 MODELS ONLY:

MOUNT THE ONE PIECE TRAP/BOTTOM ENCLOSURE TO WASHBASIN ④.

3702/3704 MODELS ONLY:

ASSEMBLE TRAP ENCLOSURES ⑤ TO BRACKETS ③ WITH SCREWS PROVIDED. REASSEMBLE BOTTOM ENCLOSURES ① TO WASHBASIN ④.



ACORN ENGINEERING COMPANY
P.O. BOX 3527 Industry, CA 91744
15125 Proctor Ave Industry, CA 91746
(626) 336-4561 FAX (626) 961-2200

TITLE **CURVED FRONT ENCLOSED BOTTOM ASSY. -CAT. #3701/3702/3703/3704 -1 -EB**

MANUFACTURE DATE	DATE ISSUED	DRAWING NUMBER
AUGUST 1997 TO PRESENT	11/26/97	
	DATE REVISED	9927-115-001
	12/28/18 D	



REFERENCE DRAWINGS		
REPAIR PARTS		DRAWING
NON-METERING SERVOMOTOR	(-F)	9955-001-003
METERING SERVOMOTOR	(-H)	9955-000-003
AIR-CONTROL VALVE BODY		9975-090-001
CHECKSTOP	(-ST Single Temp. Only)	9956-040-003
SENSOR/SOLENOID	(-SO) (24VAC)	9955-015-002
SENSOR/SOLENOID/PPZ	(-SO) (9VDC)	9955-019-002
HAND BUTTON		9957-300-001
FOOT BUTTON		9957-200-001

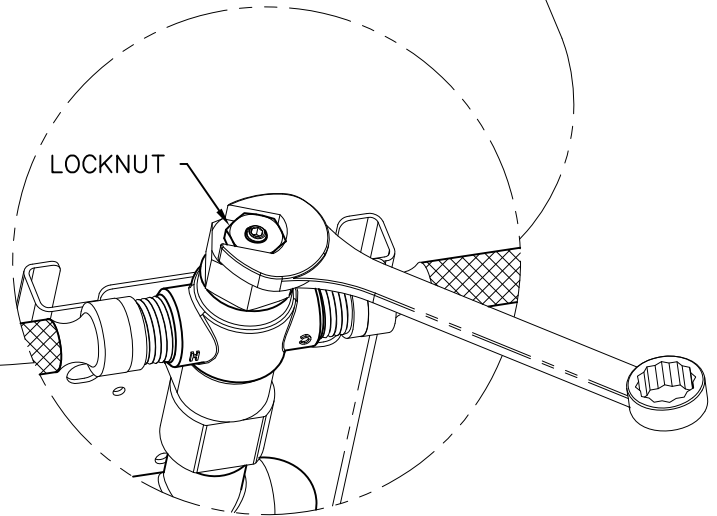
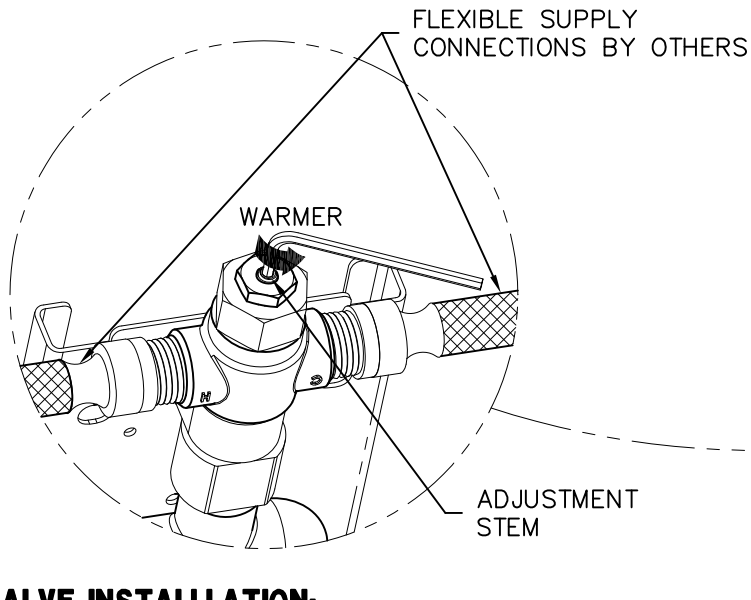
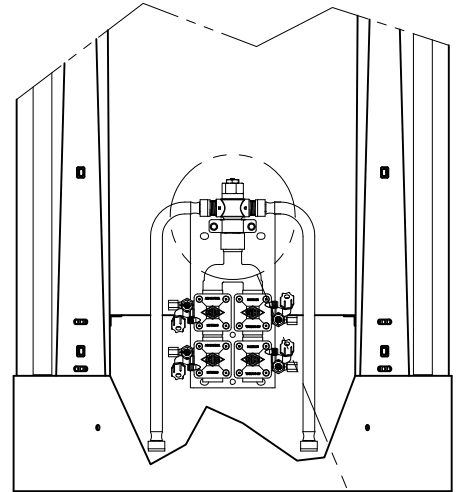

VALVE INSTALLATION:

- A- MX-T/P VALVES: AFTER THOROUGHLY FLUSHING SUPPLY LINES, MAKE UP CONNECTIONS TO SUPPLY STUB OUTS AND VALVE INLETS WITH INSTALLER PROVIDED FLEXIBLE HOSE. NOTE: MX-T/P VALVE SUPPLY INLETS ARE 1/2" NPTE.
- B- OPTIONAL -ST (Single Temp): AFTER THOROUGHLY FLUSHING SUPPLY LINE, MAKE UP CONNECTION TO SUPPLY STUB OUT AND VALVE INLET WITH FLEXIBLE HOSE PROVIDED. NOTE: -ST VALVES INCLUDE FLEXIBLE HOSE WITH 1/2" NPSI CONNECTIONS. FLEXIBLE HOSE ENDS WILL ACCOMMODATE 1/2" NPT MALE ADAPTER.
- C- SEE APPROPRIATE SERVOMOTOR REFERENCE DRAWINGS FOR VALVE DETAILS AND TIMING INSTRUCTIONS.

MX T/P TEMPERATURE VALVE ADJUSTMENT

- D- LOOSEN LOCKNUT SHOWN.
- E- TURN ON FIXTURE AND RUN WATER FOR AT LEAST 2 MINUTES. ALLOW WATER TO STABILIZE.
- F- USE AN 1/8" ALLEN WRENCH TO TURN ADJUSTMENT STEM COUNTER-CLOCKWISE FOR WARMER OR CLOCKWISE FOR COOLER OUTLET WATER TEMPERATURE.
- G- TIGHTEN LOCKNUT TO PREVENT ACCIDENTAL OR UNAUTHORIZED TEMPERATURE ADJUSTMENT.
- H- RE-CHECK OUTLET TEMPERATURE.

ACORN ENGINEERING COMPANY P.O. BOX 3527 Industry, CA 91744 15125 Proctor Ave Industry, CA 91746 (626) 336-4561 FAX (626) 961-2200	TITLE VALVE INSTALL & MIXING VALVE ADJUSTMENT		
	MANUFACTURE DATE MARCH 2014 TO PRESENT	DATE ISSUED 03/25/14	DRAWING NUMBER 9912-252-002
	DATE REVISED		

-DMJ DECK MOUNTED
"J" SPOUT SHOWN
FOR REFERENCE

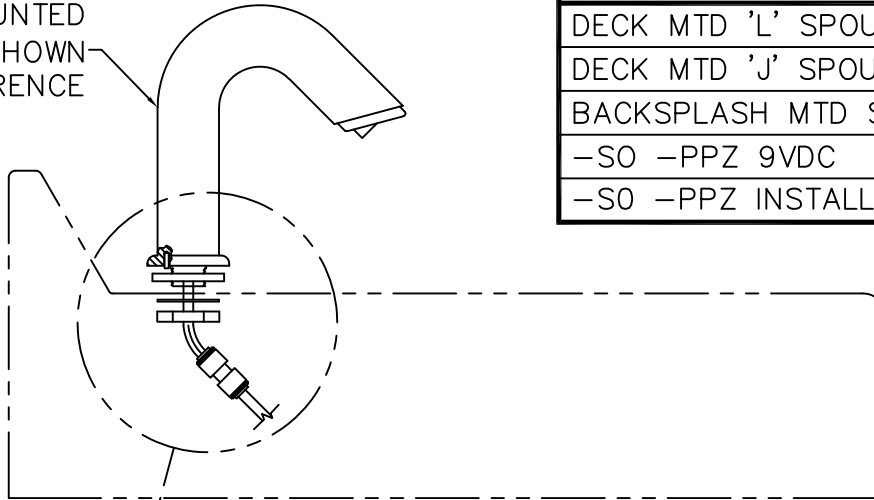

REFERENCE DRAWING	
DECK MTD 'L' SPOUT	9957-730-001
DECK MTD 'J' SPOUT	9957-731-001
BACKSPLASH MTD SPOUT	9957-732-001
-SO -PPZ 9VDC	9955-019-002
-SO -PPZ INSTALLATION	9927-221-005

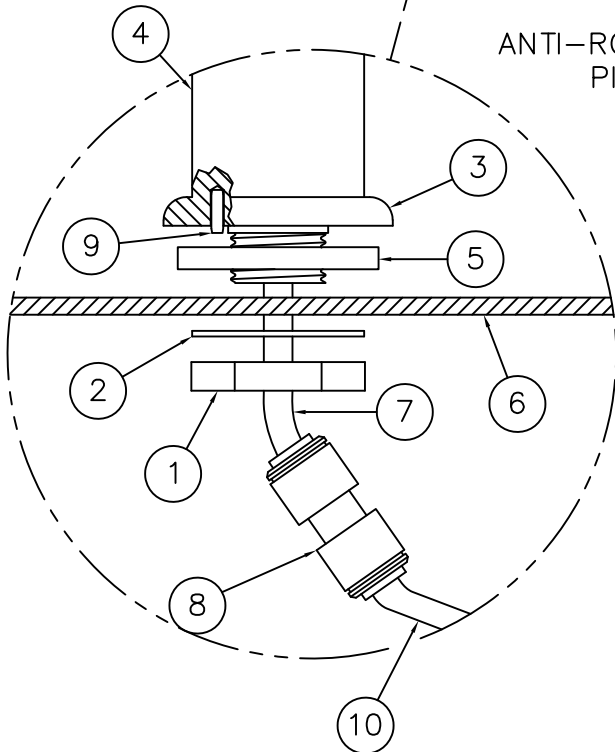

ANTI-ROTATION
PIN SLOT

ANTI-ROTATION
PIN SLOT

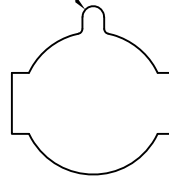

PUNCH DETAIL
STAINLESS STEEL

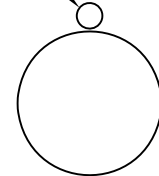

PUNCH DETAIL CORTERRA
SOLID SURFACE

INSTALLATION INSTRUCTIONS:

NOTE: INSTALL SPOUTS PRIOR TO SECURING
FIXTURE TO WALL.

- A-REMOVE BRASS NUT ① AND WASHER ② FROM THE
BASE ③ OF SPOUT ④. DO NOT REMOVE RUBBER
GASKET ⑤.
- B-FROM ABOVE DECK ⑥: MAKE SURE RUBBER GASKET
⑤ IS PROPERLY SEATED WITHIN THE BASE ③ OF
SPOUT ④. FEED TUBE ⑦ AND UNION FITTING ⑧
THRU PUNCHED OPENING. POSITION SPOUT ③ ON
DECK ⑥ WITH ANTI-ROTATION PIN ⑨ THRU DECK
PUNCHING ANTI-ROTATION SLOT.
- C-FROM BELOW DECK ⑥: REASSEMBLE BRASS NUT ①
AND WASHER ② TO THE BASE ③ OF SPOUT ④.
MAKE SURE THAT PIN ⑨ IS IN THE PUNCHING SLOT
AND THAT GASKET ⑤ SEALS PROPERLY BEFORE
TIGHTENING.
- D-CONNECT POLYETHYLENE 1/4" O.D. WATER LINE ⑩ TO
UNION FITTING ⑧ WATERTIGHT WITH THE FERRULE
NUT PROVIDED. REFER TO THE GENERAL INSTALLATION
INSTRUCTIONS FOR ADDITIONAL DETAILS.

MORRIS GROUP INTL
P.O. BOX 3527 Industry, CA 91744
MORRIS GROUP 15125 Proctor Ave Industry, CA 91746
INTERNATIONAL (626) 336-4561 FAX (626) 961-2200

TITLE **TYPICAL SPOUT INSTALLATION DETAIL**

MANUFACTURE DATE

JULY 1997
TO PRESENT

DATE ISSUED

11/26/97

DATE REVISED

03/25/14 F

DRAWING NUMBER

9927-200-001

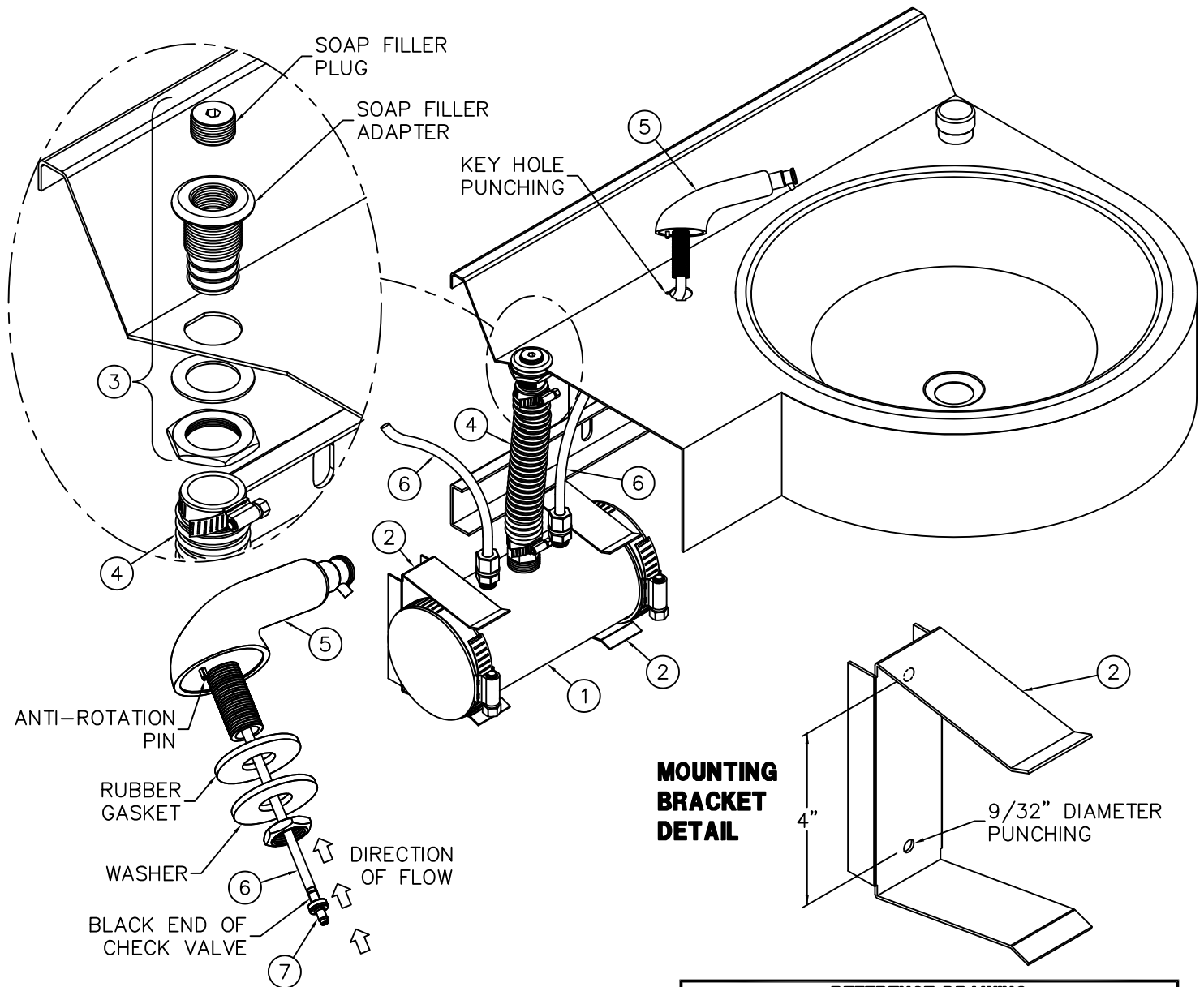

FOR BEST RESULTS INSTALL SOAP RESERVOIR FILL HOLE DIRECTLY BELOW SOAP FILLER ON DECK WITH REFILL TUBE AS SHORT AND STRAIGHT AS POSSIBLE TO FACILITATE REFILL OF SOAP WITHOUT BACKUP OR OVERFLOW.

- A- INSTALL SOAP RESERVOIR (1) TO WALL INSIDE THE TRAP ENCLOSURE USING THE MOUNTING BRACKETS (2) PROVIDED. WALL ANCHORS AND FASTENERS ARE BY OTHERS.
- B- INSTALL SOAP FILLER ASSEMBLY (3) TO DECK.
- C- ATTACH THE 1-1/4" O.D. REFILL TUBE (4) TO SOAP FILLER ASSEMBLY (3) & SOAP RESERVOIR (1) WITH THE HOSE CLAMPS PROVIDED.

MOUNTING BRACKET DETAIL

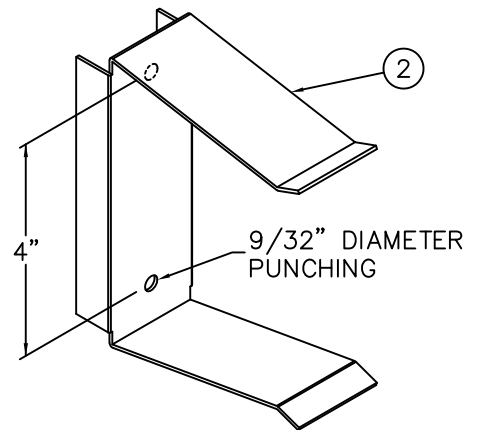

REFERENCE DRAWING	
ASSEMBLY	NUMBER
SOAP DISPENSER	9965-075-002

- D- INSTALL SOAP DISPENSER(S) (5) ONTO DECK BY ALIGNING ANTI-ROTATION PIN WITH KEY HOLE. NOTE THAT GASKET AND WASHER ARE LOCATED BENEATH THE DECK.
- E- ATTACH THE 3/8" O.D. TUBING (6) TO THE DISPENSER(S) (5) & RESERVOIR (1). NOTE: CHECK VALVE(S) (7) MUST BE FIELD SPLICED INTO TUBING (6) & INSTALLED WITH RESPECT TO DIRECTION OF FLOW.
- F- TO FILL SOAP RESERVOIR, REMOVE THE FILLER PLUG FROM THE SOAP FILLER ADAPTER. SLOWLY POUR SOAP DOWN OPENING AND REPLACE PLUG.

<p>MORRIS GROUP INTL P.O. BOX 3527 Industry, CA 91744 MORRIS GROUP 15125 Proctor Ave Industry, CA 91746 INTERNATIONAL (626) 336-4561 FAX (626) 961-2200</p>	<p>TITLE -PDM SOAP DISPENSER INSTALLATION DETAIL</p>	
	<p>MANUFACTURE DATE</p> <p>JUNE 2001</p> <p>TO PRESENT</p>	<p>DATE ISSUED</p> <p>08/24/01</p> <p>DATE REVISED</p> <p>06/22/04</p>



TWO STATION WIRING DIAGRAM SHOWN

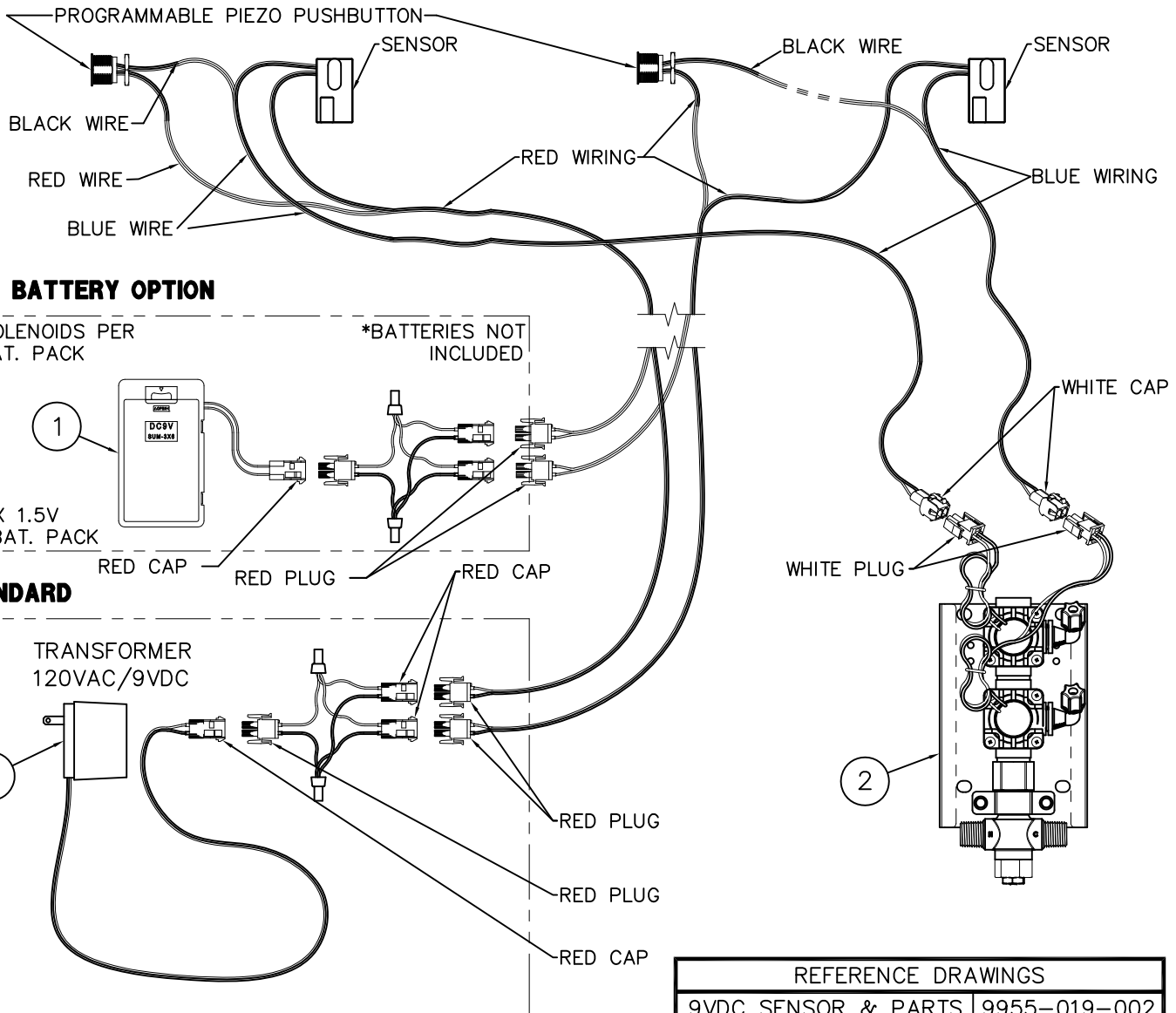

-BAT BATTERY OPTION

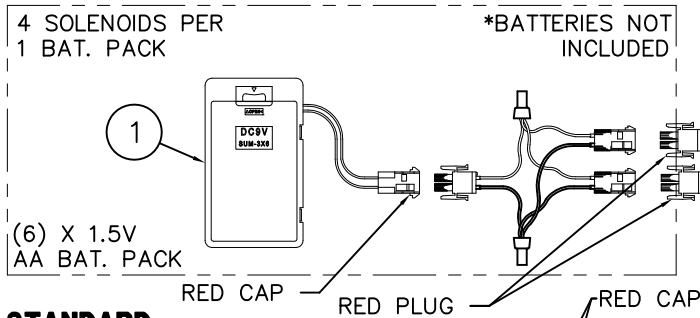

STANDARD

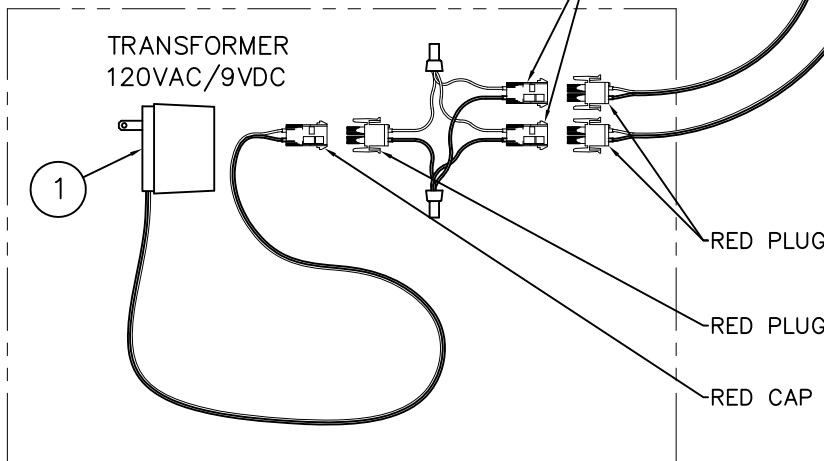

REFERENCE DRAWINGS	
9VDC SENSOR & PARTS	9955-019-002
PIEZO PB PROGRAMMING	9940-009-001

INSTALLATION INSTRUCTIONS:

- A- USING APPROPRIATE INSTALLATION INSTRUCTIONS, MOUNT FIXTURE TO WALL AND MAKE-UP WASTE PIPING CONNECTIONS. SENSOR OR ELECTRONIC PUSHBUTTON ARE FACTORY INSTALLED. POWER SUPPLY ① AND VALVE ② SHIPPED LOOSE.
 - B- INSTALL SOLENOID VALVE ASSEMBLY ② ON THE WALL (FASTENERS AND WALL ANCHORS BY OTHERS), MAKING SURE THAT THE VALVE WILL BE WITHIN BOTTOM ENCLOSURE.
 - C- CONNECT WATER SUPPLY (AFTER FLUSHING LINES) TO VALVE, AND VALVE RISER TO SPOUTS AS PER UNIT INSTALLATION INSTRUCTIONS.
 - D- CONNECT SOLENOID VALVE, POWER SUPPLY AND SENSOR WIRING AS SHOWN ON DETAIL.
 - E- COMPLETE THE INSTALLATION OF THE UNIT ACCORDING TO THE UNITS INSTALLATION INSTRUCTIONS.
- NOTE:**
- 1- PLUG-IN TRANSFORMER INCLUDES BUILT-IN SECONDARY FUSE. IN THE EVENT OF POWER SURGE TRANSFORMER MAY REQUIRE REPLACEMENT.
 - 2- ELECTRICAL RECEPTACLE MUST BE WIRED TO A GFI PROTECTED CIRCUIT. FIXTURE MUST BE EARTH GROUNDED PER N.E.C. (NATIONAL ELECTRICAL CODE).

<p>ACORN ENGINEERING COMPANY P.O. BOX 3527 Industry, CA 91744 15125 Proctor Ave Industry, CA 91746 (626) 336-4561 FAX (626) 961-2200</p>	<p>TITLE -SO SENSOR/ -PPZ PIEZO ELECTRONIC PUSHBUTTON INSTALLATION</p>		
	<p>MANUFACTURE DATE</p> <p>OCTOBER 2009</p> <p>TO PRESENT</p>	<p>DATE ISSUED</p> <p>09/06/13</p> <p>DATE REVISED</p> <p>03/25/14</p>	<p>DRAWING NUMBER</p> <p>9927-221-005</p>

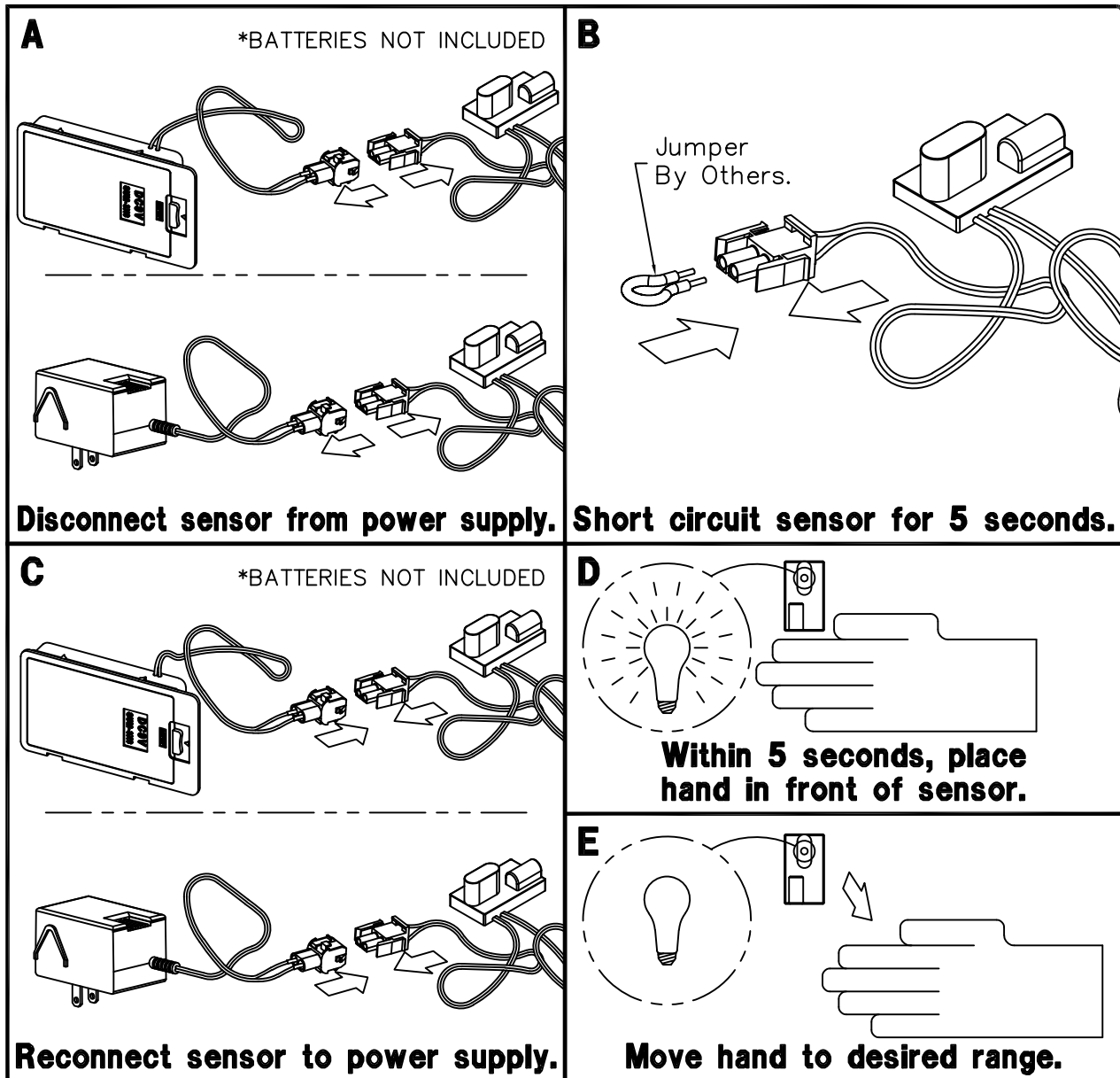

NOTE: THESE INSTRUCTIONS ONLY APPLY TO 9 VOLT SENSORS THAT DO NOT HAVE A RANGE ADJUSTMENT SCREW ON THE BACK. SEE DRAWING # 9927-222-001.

INSTRUCTIONS:

- A- Disconnect sensor from power supply.
- B- Create a short circuit between the positive and negative connections on the sensor for five seconds. **WARNING:** Do not create a short circuit on the power supply or while the sensor is connected to the power supply.
- C- Reconnect the sensor to the power supply.

- D- Within 5 seconds of making the connection, place hand 2 to 4 inches from the sensor.
- E- Once red light begins flashing quickly, move hand to preferred distance and wait for light to stop flashing.
- F- Check distance. If unsatisfactory, repeat steps A through E.

<p>MORRIS GROUP INTL P.O. BOX 3527 Industry, CA 91744 MORRIS GROUP 15125 Proctor Ave Industry, CA 91746 INTERNATIONAL (626) 336-4561 FAX (626) 961-2200</p>	<p>TITLE 9 VOLT DC SENSOR RANGE ADJUSTMENT</p>	
	<p>MANUFACTURE DATE SEPTEMBER, 2001 TO PRESENT</p>	<p>DATE ISSUED 09/06/01</p> <p>DATE REVISED 02/18/14</p>



MUST SPECIFY:

3701 UNI-BASIN QUANTITY:	<input type="checkbox"/> -ECL	<input type="checkbox"/> -ECR
3702 DUAL-BASIN QUANTITY:	<input type="checkbox"/> -ECL	<input type="checkbox"/> -ECR
3703 TRI-BASIN QUANTITY:	<input type="checkbox"/> -ECL	<input type="checkbox"/> -ECR
3704 QUAD BASIN QUANTITY:	<input type="checkbox"/> -ECL	<input type="checkbox"/> -ECR

STANDARD WIDTHS *LESS -ECL/-ECR

3701 UNI-BASIN	19"
3702 DUAL-BASIN	49"
3703 TRI-BASIN	79"
3704 QUAD-BASIN	109"

SPECIFY EXTENDED COUNTERTOP WIDTH BELOW.

**MERIDIAN® STAINLESS STEEL
DUAL-BASIN, 3702 SHOWN FOR
REFERENCE ONLY.**

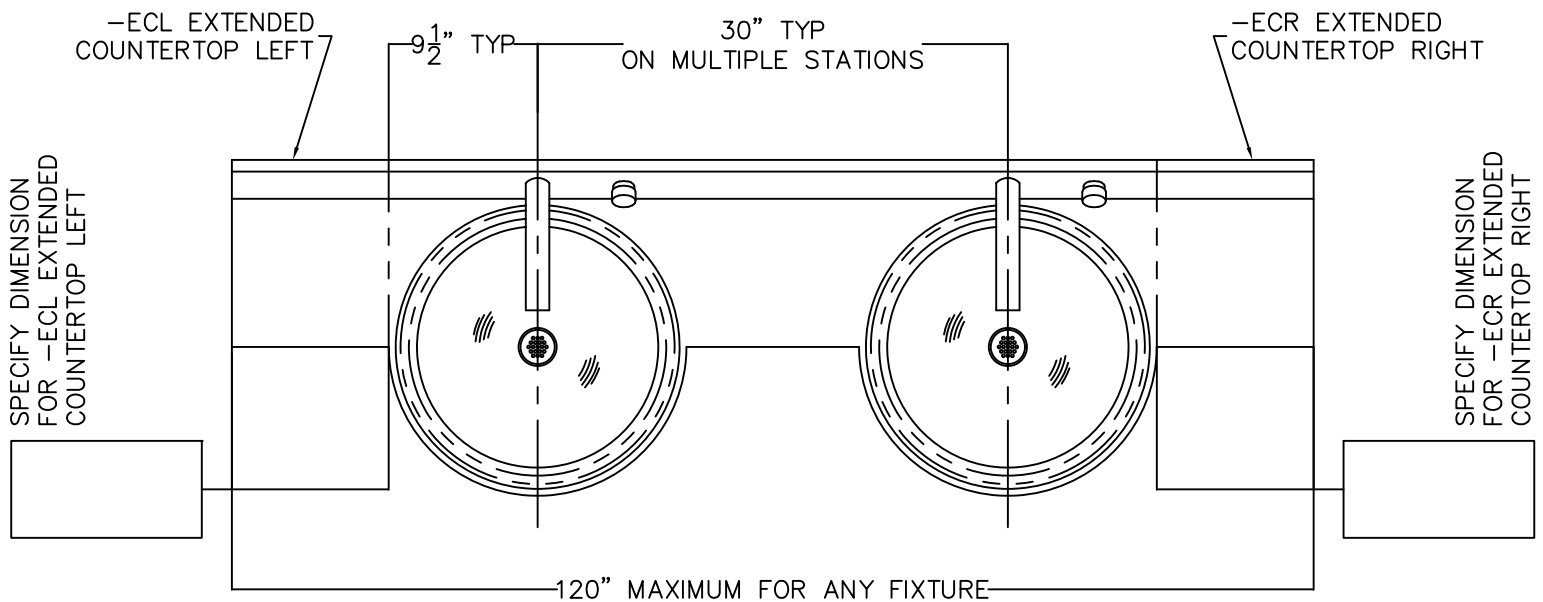

ORDERING INSTRUCTIONS:

SPECIFY WHERE INDICATED COUNTERTOP SIDE(S) TO BE EXTENDED AND DIMENSION(S) REQUIRED. MAXIMUM OVERALL WIDTH IS 120".

NOTE: WHEN -ECL OR -ECR OPTIONS ARE SELECTED, ONLY THE COUNTERTOP IS EXTENDED; TRAP ENCLOSURES REMAIN THE SAME AS STANDARD. LENGTHS ARE SUBJECT TO FACTORY APPROVAL. ALL DIMENSIONS ARE SUBJECT TO MANUFACTURER'S TOLERANCE OF PLUS OR MINUS 1/4" WITH OVERALL TOLERANCE OF PLUS OR MINUS 1/2".

<p>ACORN ENGINEERING COMPANY P.O. BOX 3527 Industry, CA 91744 15125 Proctor Ave Industry, CA 91746 (626) 336-4561 FAX (626) 961-2200</p>	<p>TITLE 3700 SERIES MULTI-BASIN FIXTURES -ECL / -ECR</p>		
	<p>MANUFACTURE DATE</p> <p>AUGUST 1997</p> <p>TO PRESENT</p>	<p>DATE ISSUED</p> <p>07/15/10</p>	<p>DRAWING NUMBER</p> <p>9927-128-001</p>
		<p>DATE REVISED</p> <p>12/28/18</p>	



Programable Piezo Pushbutton Programming Instructions (Flow Time Adjustment)

The Button is factory set an 8 sec. timing cycle, if an 8 sec. cycle is adequate, then **no** programming adjustment is required.



NOTE: Read the entire document before trying to program the piezo pushbutton.

THE TIME SETTINGS PROGRAM USES 3 DIFFERENT TIMING MODES:

- **1 second timing mode:** Each push of the button adds 1 second to the total timing cycle.
- **5 second timing mode:** Each push of the button adds 5 seconds to the total timing cycle.
- **20 second timing mode:** Each push of the button adds 20 seconds to the total timing cycle.

To program the piezo pushbutton, you will need to be able to see the back of the piezo pushbutton.

Prevision must be made to access the back of the piezo pushbutton. There is an LED on the back of the piezo pushbutton under a layer of transparent epoxy, used as a programming indicator light.



NOTE: This programming procedure moves along rapidly, there is only about 2 or 3 seconds between programming operations.

In order to start the programming the piezo pushbutton, the button must be powered down. Disconnect the red power cable and wait 20 seconds, then reconnect the red power cable.

As soon as the cable is reconnected the LED will start flashing, it will flash 4 times, then stays on for 3 seconds. During the 3 second period, push the piezo button once, the LED will go out, now you are in the **1 sec timing mode** and each time the button is pushed the LED will flash, adding 1 sec to the total timing cycle.

To move on to the **5 sec timing mode**, pause and wait for the LED to flash 2 times, now you are in the 5 sec timing mode. Each time the button is pushed the LED will flash, adding 5 sec to the total timing cycle.

To move on to the **20 sec timing mode**, pause and wait for the LED to flash 3 times, now you are in the 20 sec timing mode and each time the button is pushed the LED will flash, adding 20 sec to the total timing cycle. After programing is complete, pause and wait for the LED to flash 4 times and then 5 times, which completes the programming.

- When a **timing mode is not required** then **do not** push the button and wait for the next timing mode.
- Each timing mode (1 sec, 5 sec or 20 sec timing mode) can be sequenced up to 100 times, that is the number of times, the button can be pushed, to increase the total timing cycle in each timing mode.



Please visit www.acorneng.com for most current specifications.

Programmable Piezo Pushbutton Programming Instructions (Flow Time Adjustment)

WORKSHEET

(FILL IN ALL BOXES, WHICH WILL SIMPLIFY THE PROGRAMMING PROCEDURE)

Fill in all the Boxes below
↓ ↓

Determine the number of seconds per timing cycle

1 Push = 1 Second
 x 1 = sec



- PROGRAMING STEPS:**
- Power down piezo button for 10 seconds.
 - Reconnect power.
 - LED flashes, then stay on.
 - While the LED is steady on, push button.
 - LED turns off.
 - You are in the 1 sec timing mode, immediately push the button, 1 push equals 1 sec added to the total timing cycle.
 - Pause and wait for the LED to flash 2 times.

ADD ↑ ↓

1 Push = 5 Seconds
 x 5 = sec



- You are in the 5 sec timing mode, immediately push the button, 1 push equals 5 sec added to the total timing cycle.
- Pause and wait for the LED to flash 3 times.

ADD ↑ ↓

1 Push = 20 Seconds
 x 20 = sec



- You are in the 20 sec timing mode, immediately push the button, 1 push equals 20 sec added to the total timing cycle.

EQUALS ↓

Total timing cycle equals
 seconds



INSTALLATION, OPERATIONS & MAINTENANCE MANUAL

Please visit www.acorneng.com
for most current specifications.

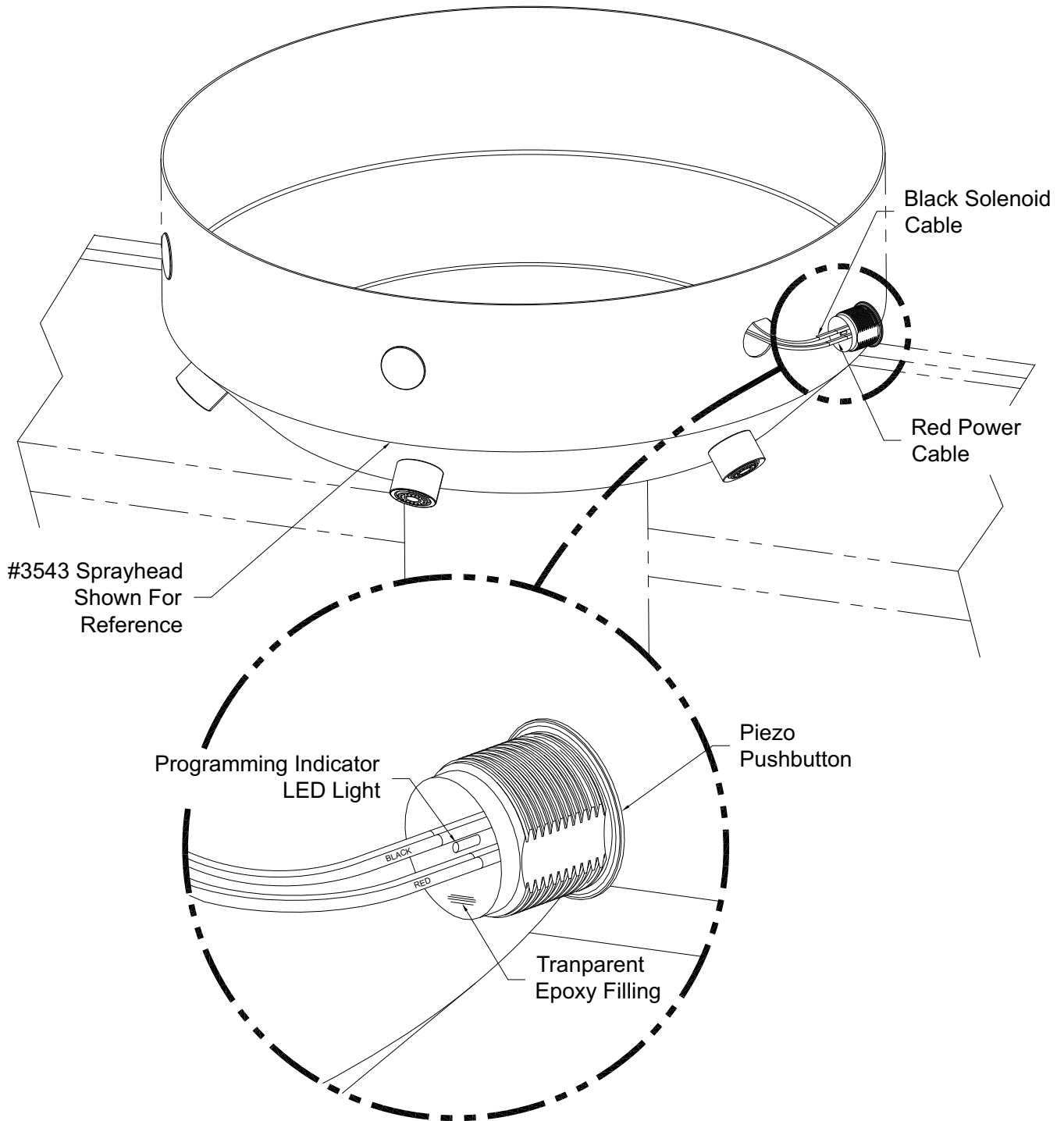

Part #: 9940-009-001

New: 10/01/13

ACORN ENGINEERING COMPANY

ACORN ENGINEERING FIELD SERVICE
TOLL FREE 800-743-8259 • LOCAL 626-855-4866 • FAX 626-855-4863