

REF NO.:

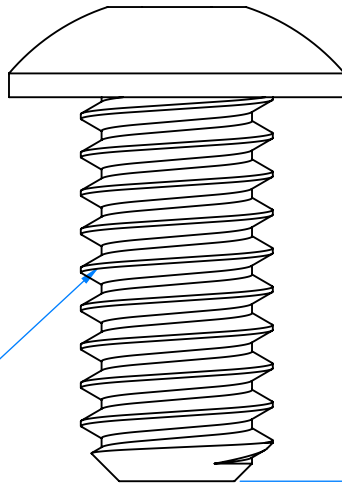
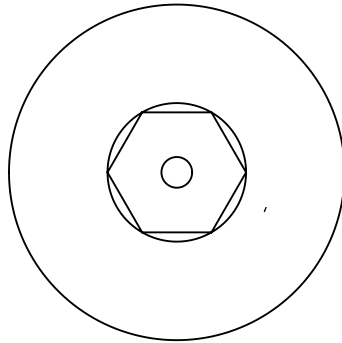
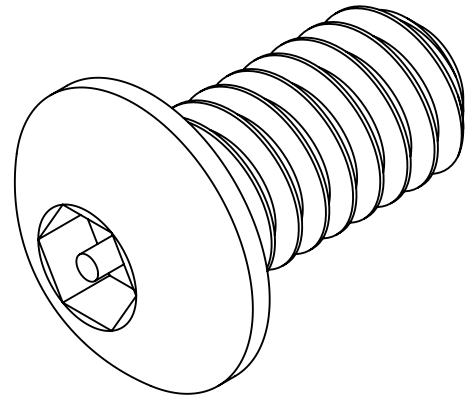

1/4-20 UNC x 1/2"

0.500

QTY: 10 PACK.

MATL:TYPE 300 SERIES STAINLESS STEEL

 ACORN ENGINEERING COMPANY P.O. BOX 3527 INDUSTRY, CA. 91744 (626)336-4561 FAX (626) 961-2200	TITLE 1/4-20 x 1/2" BTN HD CTR REJ SCREW			MATERIAL TYPE HALB		
	JOB OR SECTION M/C MACHINE SCREWS			DRAWING NUMBER 0112-007-001W		
	SCALE 4:1	DATE 11/05/07	DRN. BY RCL	ECO REVISION	REV. DATE	SHEET 1 OF 1