

REF NO.:

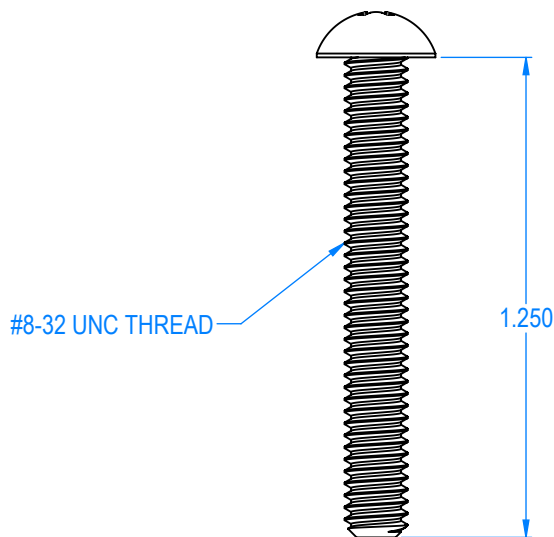

**QTY: 10 PACK.**

MATL: 18-8 SERIES STAINLESS STEEL

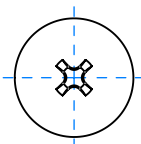
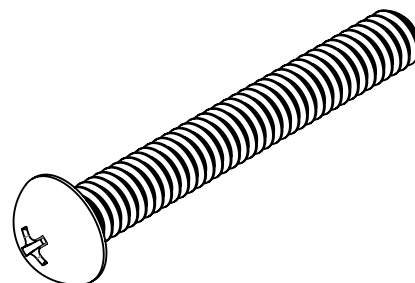

ACORN ENGINEERING COMPANY  
P.O. BOX 3527 INDUSTRY, CA. 91744  
(626)336-4561 FAX (626) 961-2200

TITLE #8-32 x 1-1/4" S/S PHIL RD HD SCREW, 10-PK			MATERIAL TYPE HALB		
JOB OR SECTION M/C MACHINE SCREWS			DRAWING NUMBER 0116-012-001W		
SCALE 2:1	DATE 02-02-89	DRN. BY R.F.T.	ECO REVISION	REV. DATE	SHEET 1 OF 1