

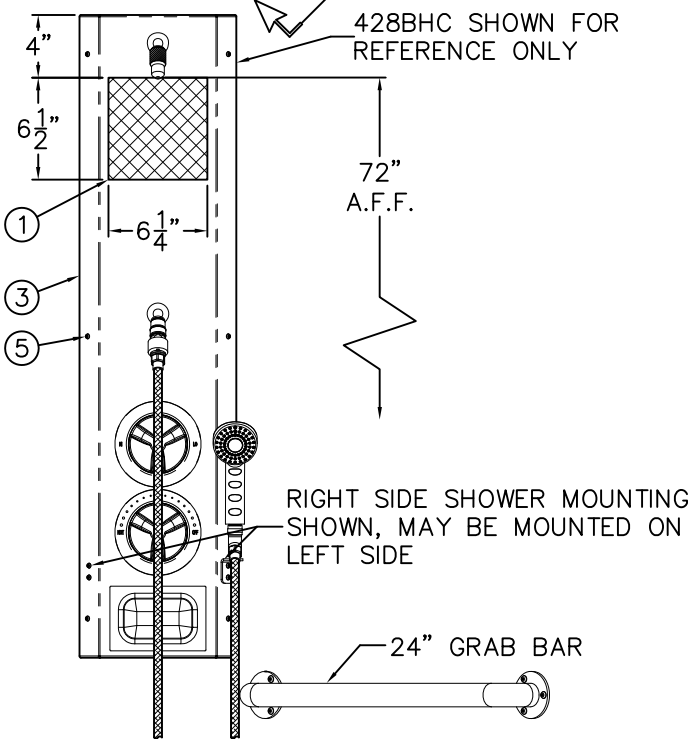

**REFERENCE DRAWINGS**

FLO-CLOZ	9975-000-001	AIR-CONTROL VALVE BODY	9975-090-001
T/P VALVE (SHOWN)	9975-005-002	VALVE CONNECT INSTALL	9905-006-001
SHOWERHEAD	9970-122-001	TINNERMAN NUT	9951-007-001
FLEX SHOWERHEAD	9970-102-003	PANEL SCREW	9951-005-001
GLIDE RAIL	9970-103-001	PUSHBUTTON/ESCUTCHEON	9957-300-001
DIVERTER	9975-080-001	T/P VALVE ADJUSTMENT	9900-007-001
FOLDING SEAT INSTALL	9900-350-001	T/P VALVES PRIOR TO JUNE 2014	9975-006-001

**-T TOP SUPPLY**

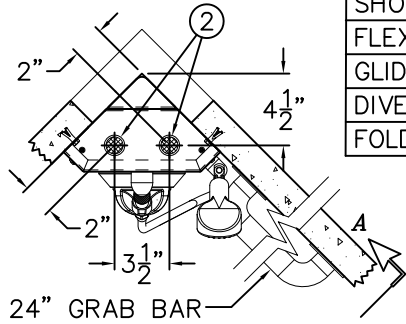

**VIEW FROM OTHER SIDE OF FIXTURE IS MIRROR IMAGE**

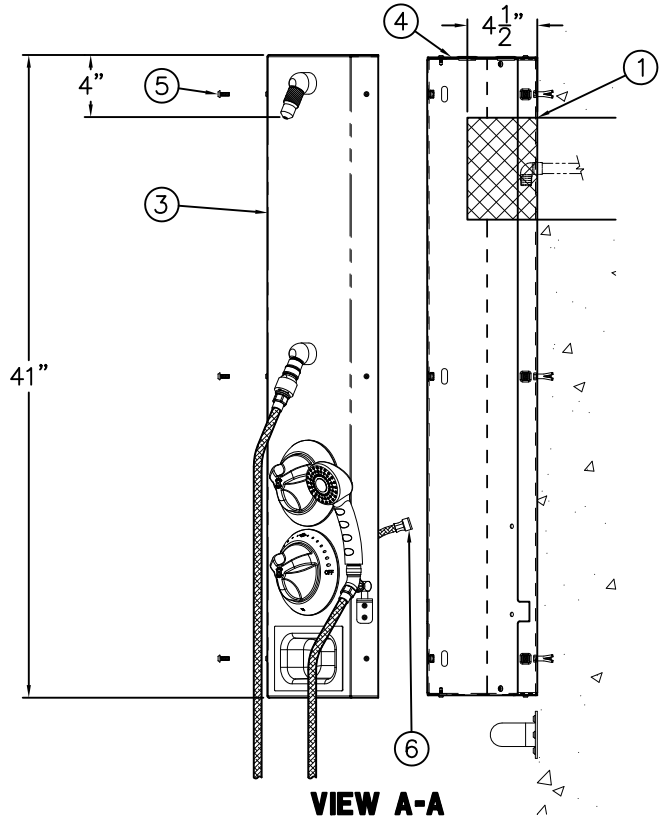

**NOTE:**

MAXIMUM RECOMMENDED WORKING PRESSURE IS 100PSI; TEMPERATURE IS 130°F; OUTLET TEMPERATURE IS RECOMMENDED AT A MAXIMUM OF 105°F.

**INSTALLATION INSTRUCTIONS:**

- A- PROVIDE SUPPLY ROUGH-IN(S) IN THE AREA INDICATED FOR ① WALL SUPPLY, AND ② FOR TOP SUPPLY. THOROUGHLY FLUSH SUPPLY LINES.
- B- DISASSEMBLE SHOWER PANEL ASSEMBLY ③ FROM WALL MOUNTING FRAME ④ BY REMOVING VANDAL-RESISTANT SCREWS ⑤ FROM THE HOUSING.
- C- INSTALL MOUNTING FRAME ④ AT DESIRED HEIGHT AND ANCHOR FRAME TO BOTH WALLS USING HARDWARE BY OTHERS.

- D- MAKE-UP SUPPLY CONNECTIONS TO 1/2" NPS FLEX HOSE FEMALE ENDS ⑥ WHILE SUPPORTING PANEL OFF THE FLOOR. (NOTE: SUPPLY INLET CONNECTION WILL ACCOMMODATE 1/2" NPT MALE ADAPTER.)
- E- ASSEMBLE THE SHOWER PANEL ③ TO MOUNTING FRAME ④ USING SCREWS ⑤ PROVIDED.

**WARNING:**

PRIOR TO MAKING INSTALLATION, SUPPLY LINES MUST BE FLUSHED OF ALL FOREIGN MATERIAL SUCH AS PIPE DOPE, CHIPS, SOLDER, ETC. VALVE MUST BE DRAINED PRIOR TO BEING SUBJECTED TO FREEZING TEMPERATURES.



ACORN ENGINEERING COMPANY  
P.O. BOX 3527 Industry, CA 91744  
15125 Proctor Ave Industry, CA 91746  
(626) 336-4561 FAX (626) 961-2200

TITLE <b>APEX FLUSH MOUNTED CORNER SHOWER (420BHC SERIES)</b>		
MANUFACTURE DATE <b>DECEMBER 2010 TO PRESENT</b>	DATE ISSUED <b>01/19/11</b>	DRAWING NUMBER <b>9900-050-002</b>
	DATE REVISED <b>06/01/14 C</b>	



**MVC1-MA2 WIRING DIAGRAM SHOWN FOR REFERENCE ONLY**

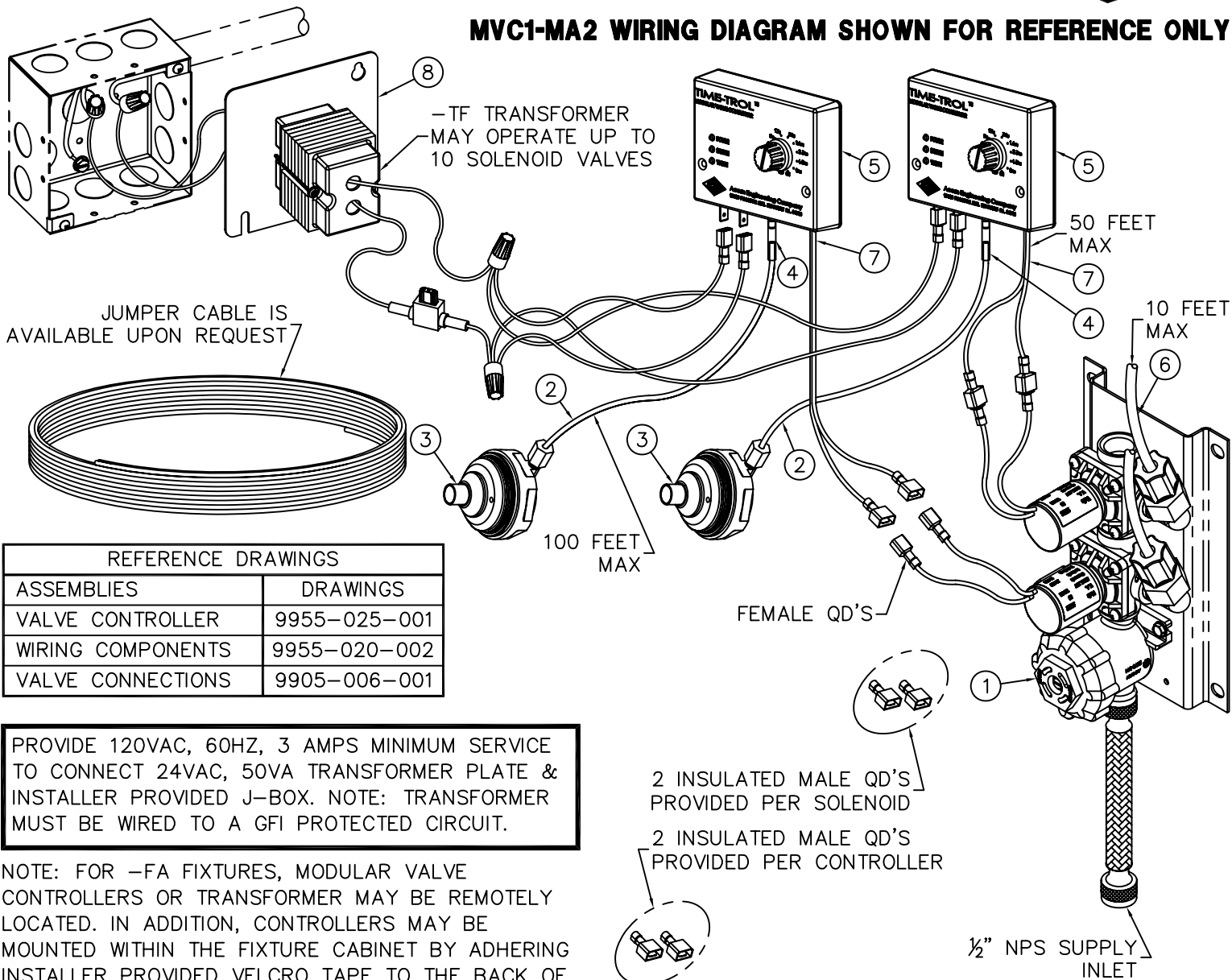

REFERENCE DRAWINGS	
ASSEMBLIES	DRAWINGS
VALVE CONTROLLER	9955-025-001
WIRING COMPONENTS	9955-020-002
VALVE CONNECTIONS	9905-006-001

PROVIDE 120VAC, 60HZ, 3 AMPS MINIMUM SERVICE TO CONNECT 24VAC, 50VA TRANSFORMER PLATE & INSTALLER PROVIDED J-BOX. NOTE: TRANSFORMER MUST BE WIRED TO A GFI PROTECTED CIRCUIT.

NOTE: FOR -FA FIXTURES, MODULAR VALVE CONTROLLERS OR TRANSFORMER MAY BE REMOTELY LOCATED. IN ADDITION, CONTROLLERS MAY BE MOUNTED WITHIN THE FIXTURE CABINET BY ADHERING INSTALLER PROVIDED VELCRO TAPE TO THE BACK OF THE CONTROLLER AND ONTO FIXTURE CABINET.

**INSTALLATION INSTRUCTIONS:**

- A- ROUGH-IN & INSTALL FIXTURE PER MANUFACTURER'S INSTRUCTIONS.
- B- MOUNT SOLENOID VALVE ASSEMBLY (1) WITHIN THE CHASE OR FIXTURE FRAME / CABINET AS REQUIRED A MAXIMUM OF 10 FEET FROM THE FIXTURE.
- C- CONNECT AIR TUBING (2) TO MOUNTED PUSHBUTTON ASSEMBLY (3) AND HAND TIGHTEN FERRULE NUT. CONNECT THE TAG END OF THE AIR TUBING (2) TO THE VALVE CONTROLLER TUBE (4) AT THE POSITION MARKED "ACTUATOR" ON THE CONTROLLER (5). AIR TUBING FITS INSIDE THE CONTROLLER TUBE (4).

2 INSULATED MALE QD'S PROVIDED PER SOLENOID  
2 INSULATED MALE QD'S PROVIDED PER CONTROLLER

- D- CONNECT RISER TUBING (6) TO VALVE ASSEMBLY AND FIXTURE DISCHARGE CONNECTOR. HAND TIGHTEN USING FERRULE NUTS PROVIDED.
- E- CONNECT CONTROLLER WIRES (7) (INDICATED AS "VALVE" ON THE CONTROLLER) FROM VALVE CONTROLLER (2) TO SOLENOID VALVE (1).
- F- MAKE UP CONNECTIONS FROM TRANSFORMER (8) TO CONTROLLERS IN PARALLEL AS SHOWN.
- G- AFTER THOROUGHLY FLUSHING SUPPLY LINES MAKE UP SUPPLY CONNECTIONS.
- H- SET TIMING ON VALVE CONTROLLER (5) TO DESIRED FLOW DURATION.

ACORN ENGINEERING COMPANY P.O. BOX 3527 INDUSTRY, CA. 91744 (626) 336-4561 FAX (626) 961-2200	TITLE <b>MVC1 TIME-TROL SINGLE TEMP VALVE INSTALLATION</b>		
	MANUFACTURE DATE <b>MAY 1990</b> <b>TO PRESENT</b>	DATE ISSUED <b>08/05/10</b>	DRAWING NUMBER <b>9900-001-004</b>



**EVS1-MA2 WIRING DIAGRAM SHOWN FOR REFERENCE ONLY**

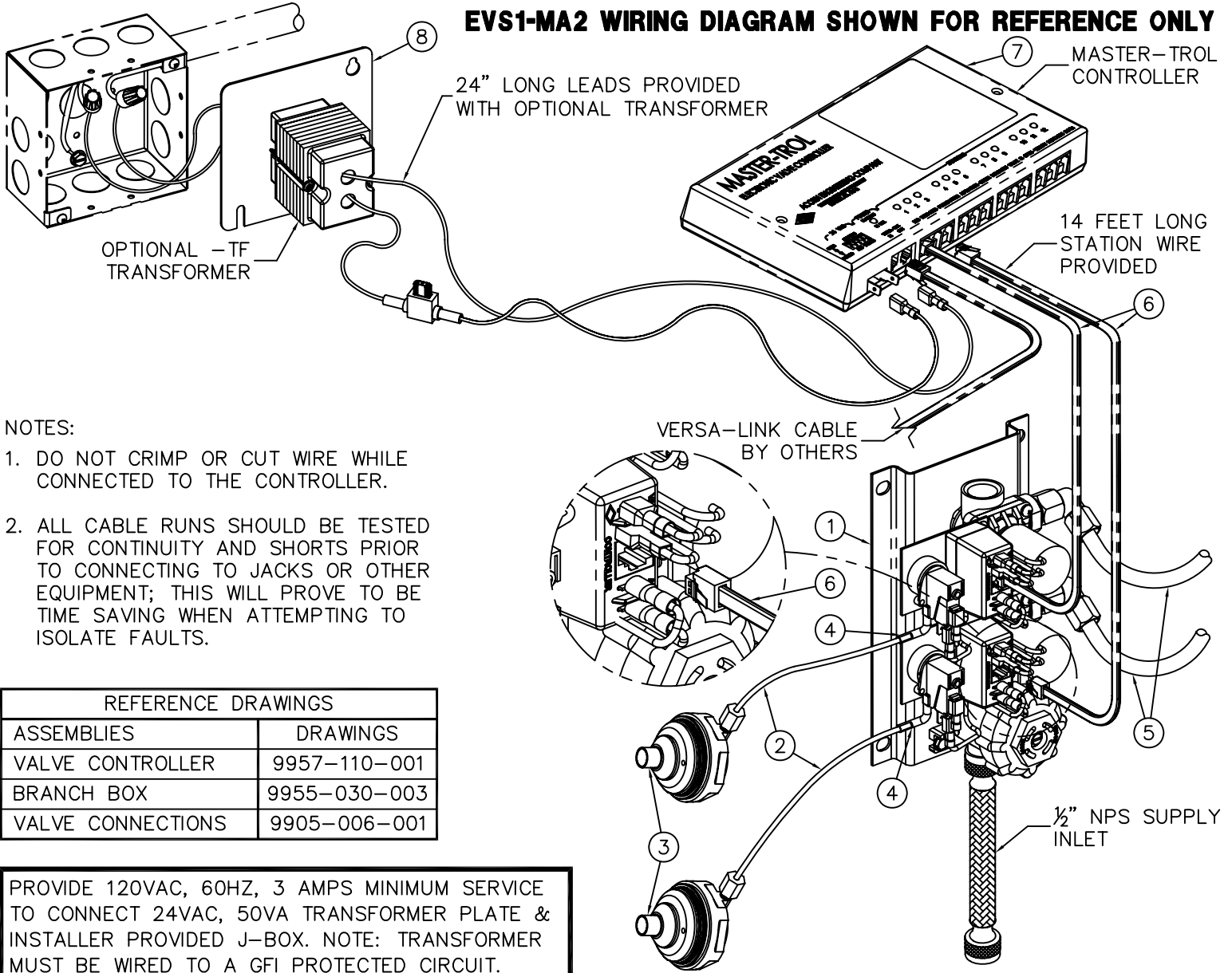

**NOTES:**

1. DO NOT CRIMP OR CUT WIRE WHILE CONNECTED TO THE CONTROLLER.
2. ALL CABLE RUNS SHOULD BE TESTED FOR CONTINUITY AND SHORTS PRIOR TO CONNECTING TO JACKS OR OTHER EQUIPMENT; THIS WILL PROVE TO BE TIME SAVING WHEN ATTEMPTING TO ISOLATE FAULTS.

REFERENCE DRAWINGS	
ASSEMBLIES	DRAWINGS
VALVE CONTROLLER	9957-110-001
BRANCH BOX	9955-030-003
VALVE CONNECTIONS	9905-006-001

PROVIDE 120VAC, 60HZ, 3 AMPS MINIMUM SERVICE TO CONNECT 24VAC, 50VA TRANSFORMER PLATE & INSTALLER PROVIDED J-BOX. NOTE: TRANSFORMER MUST BE WIRED TO A GFI PROTECTED CIRCUIT.

**INSTALLATION INSTRUCTIONS:**

- A. ROUGH-IN & INSTALL FIXTURE PER MANUFACTURER'S INSTRUCTIONS.
- B. MOUNT SOLENOID VALVE ASSEMBLY (1) WITHIN THE CHASE OR FIXTURE FRAME / CABINET AS REQUIRED A MAXIMUM OF 10 FEET FROM THE FIXTURE.
- C. CONNECT AIR TUBING (2) TO MOUNTED PUSHBUTTON ASSEMBLY (3) AND HAND TIGHTEN FERRULE NUT. CONNECT THE TAG END OF THE AIR TUBING (2) TO THE BRANCH BOX PRESSURE SWITCH 3/16" OD TUBE (4). AIR TUBING (2) FITS INSIDE THE PRESSURE SWITCH 3/16" OD TUBE (4).
- D. CONNECT RISER TUBING (5) TO VALVE ASSEMBLY AND FIXTURE DISCHARGE CONNECTOR. HAND TIGHTEN USING FERRULE NUTS PROVIDED.
- E. CONNECT STATION WIRE (6) TO BRANCH BOX AND APPROPRIATE LOCATION ON CONTROLLER.
- F. MAKE UP CONNECTIONS FROM TRANSFORMER (8) TO CONTROLLER AS SHOWN.
- G. AFTER THOROUGHLY FLUSHING SUPPLY LINES MAKE UP SUPPLY CONNECTIONS.

<p>ACORN ENGINEERING COMPANY P.O. BOX 3527 INDUSTRY, CA. 91744 (626) 336-4561 FAX (626) 961-2200</p>	<p>TITLE <b>EVS1 MASTER-TROL SINGLE TEMP VALVE INSTALLATION</b></p>		
	<p>MANUFACTURE DATE</p> <p><b>MAY 1998</b></p> <p><b>TO PRESENT</b></p>	<p>DATE ISSUED</p> <p><b>12/09/10</b></p>	<p>DRAWING NUMBER</p> <p><b>9905-330-004</b></p>
		<p>DATE REVISED</p>	



**TWO STATION AND ADA WIRING DIAGRAM SHOWN**

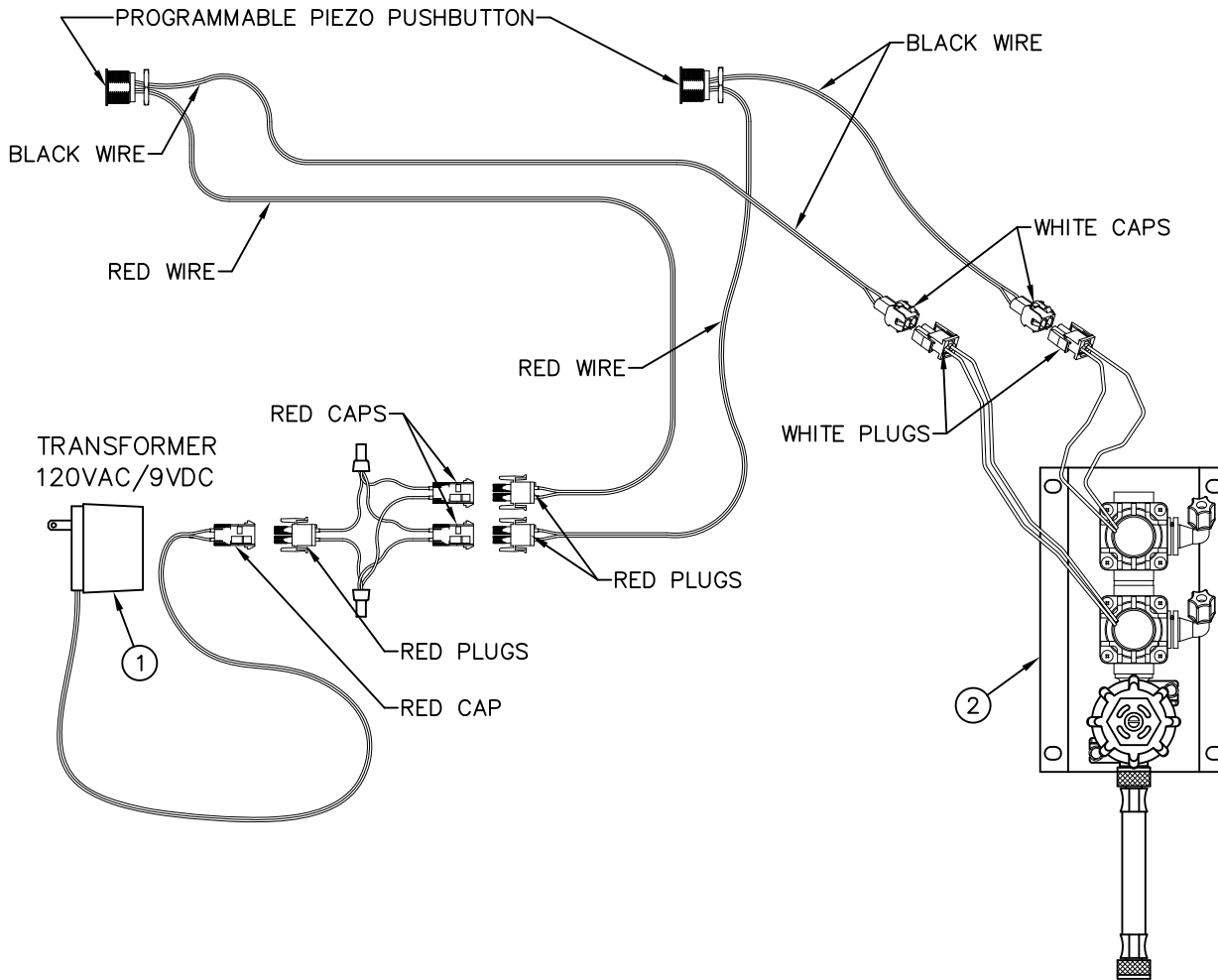

REFERENCE DRAWINGS	
9VDC SENSOR & PARTS	9955-019-002
PIEZO PB PROGRAMMING	9940-009-001

**INSTALLATION INSTRUCTIONS:**

A- USING APPROPRIATE INSTALLATION INSTRUCTIONS, MOUNT FIXTURE TO WALL AND MAKE-UP SUPPLY CONNECTIONS. ELECTRONIC PUSHBUTTON ARE FACTORY INSTALLED. POWER SUPPLY ① AND VALVE ② SHIPPED LOOSE.

B- INSTALL SOLENOID VALVE ASSEMBLY ② ON THE WALL (FASTENERS AND WALL ANCHORS BY OTHERS), MAKING SURE THAT THE VALVE WILL BE WITHIN HOUSING OR BLOCKOUT AREA.

C- CONNECT WATER SUPPLY (AFTER FLUSHING LINES) TO VALVE, AND VALVE RISER TO SHOWERHEAD AS PER UNIT INSTALLATION INSTRUCTIONS.

D- CONNECT SOLENOID VALVE, POWER SUPPLY AND SENSOR WIRING AS SHOWN ON DETAIL.

E- COMPLETE THE INSTALLATION OF THE UNIT ACCORDING ACORDING TO THE UNITS INSTALLATION INSTRUCTIONS.

**NOTE:**

1- PLUG-IN TRANSFORMER INCLUDES BUILT-IN SECONDARY FUSE. IN THE EVENT OF POWER SURGE TRANSFORMER MAY REQUIRE REPLACEMENT.

2- ELECTRICAL RECEPTACLE MUST BE WIRED TO A GFI PROTECTED CIRCUIT. FIXTURE MUST BE EARTH GROUNDED PER N.E.C. (NATIONAL ELECTRICAL CODE).



ACORN ENGINEERING COMPANY  
P.O. BOX 3527 Industry, CA 91744  
15125 Proctor Ave Industry, CA 91746  
(626) 336-4561 FAX (626) 961-2200

TITLE <b>-PPZ PIEZO ELECTRONIC PUSHBUTTON INSTALLATION</b>		
MANUFACTURE DATE <b>OCTOBER 2013 TO PRESENT</b>	DATE ISSUED <b>10/11/13</b>	DRAWING NUMBER <b>9927-223-001</b>
	DATE REVISED	



## Programable Piezo Pushbutton Programming Instructions (Flow Time Adjustment)

The Button is factory set an 8 sec. timing cycle, if an 8 sec. cycle is adequate, then **no** programming adjustment is required.



**NOTE:** Read the entire document before trying to program the piezo pushbutton.

### **THE TIME SETTINGS PROGRAM USES 3 DIFFERENT TIMING MODES:**

- **1 second timing mode:** Each push of the button adds 1 second to the total timing cycle.
- **5 second timing mode:** Each push of the button adds 5 seconds to the total timing cycle.
- **20 second timing mode:** Each push of the button adds 20 seconds to the total timing cycle.

To program the piezo pushbutton, you will need to be able to see the back of the piezo pushbutton.

Prevision must be made to access the back of the piezo pushbutton. There is an LED on the back of the piezo pushbutton under a layer of transparent epoxy, used as a programming indicator light.



**NOTE:** This programming procedure moves along rapidly, there is only about 2 or 3 seconds between programming operations.

In order to start the programming the piezo pushbutton, the button must be powered down. Disconnect the red power cable and wait 20 seconds, then reconnect the red power cable.

As soon as the cable is reconnected the LED will start flashing, it will flash 4 times, then stays on for 3 seconds. During the 3 second period, push the piezo button once, the LED will go out, now you are in the **1 sec timing mode** and each time the button is pushed the LED will flash, adding 1 sec to the total timing cycle.

To move on to the **5 sec timing mode**, pause and wait for the LED to flash 2 times, now you are in the 5 sec timing mode. Each time the button is pushed the LED will flash, adding 5 sec to the total timing cycle.

To move on to the **20 sec timing mode**, pause and wait for the LED to flash 3 times, now you are in the 20 sec timing mode and each time the button is pushed the LED will flash, adding 20 sec to the total timing cycle. After programing is complete, pause and wait for the LED to flash 4 times and then 5 times, which completes the programming.

- When a **timing mode is not required** then **do not** push the button and wait for the next timing mode.
- Each timing mode (1 sec, 5 sec or 20 sec timing mode) can be sequenced up to 100 times, that is the number of times, the button can be pushed, to increase the total timing cycle in each timing mode.



Please visit [www.acorneng.com](http://www.acorneng.com) for most current specifications.

# Programmable Piezo Pushbutton Programming Instructions (Flow Time Adjustment)

## WORKSHEET

**(FILL IN ALL BOXES, WHICH WILL SIMPLIFY THE PROGRAMMING PROCEDURE)**

Fill in all the Boxes below  
↓ ↓

Determine the number of seconds per timing cycle

1 Push = 1 Second  
 x 1 =  sec



- PROGRAMING STEPS:**
- Power down piezo button for 10 seconds.
  - Reconnect power.
  - LED flashes, then stay on.
  - While the LED is steady on, push button.
  - LED turns off.
  - You are in the 1 sec timing mode, immediately push the button, 1 push equals 1 sec added to the total timing cycle.
  - Pause and wait for the LED to flash 2 times.

**ADD** ↑ ↓

1 Push = 5 Seconds  
 x 5 =  sec



- You are in the 5 sec timing mode, immediately push the button, 1 push equals 5 sec added to the total timing cycle.
- Pause and wait for the LED to flash 3 times.

**ADD** ↑ ↓

1 Push = 20 Seconds  
 x 20 =  sec



- You are in the 20 sec timing mode, immediately push the button, 1 push equals 20 sec added to the total timing cycle.

**EQUALS** ↓

Total timing cycle equals  
 seconds



# INSTALLATION, OPERATIONS & MAINTENANCE MANUAL

Please visit [www.acorneng.com](http://www.acorneng.com)  
for most current specifications.

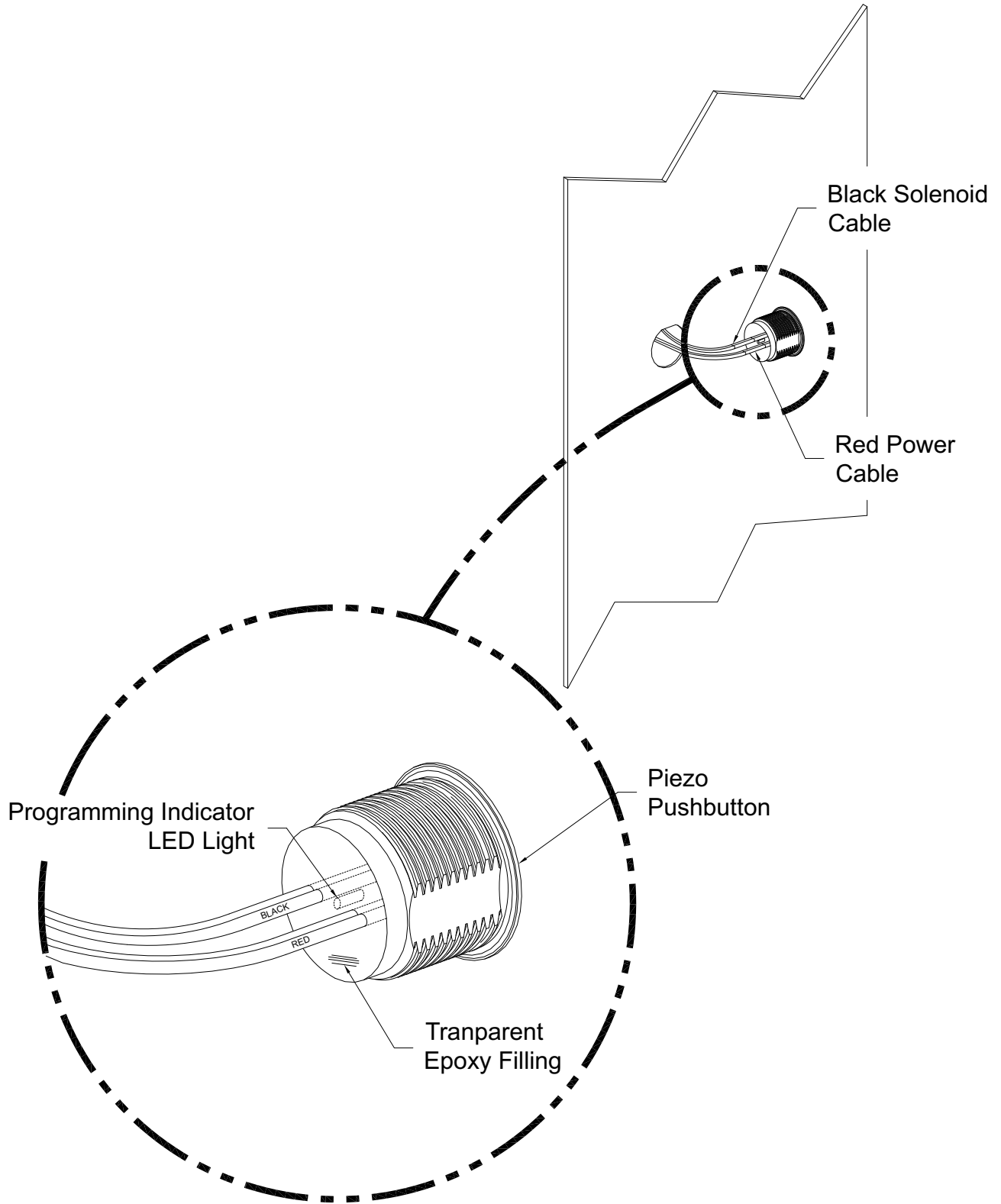



**IMPORTANT!**

WALL ANCHORS AND ANCHORING HARDWARE ARE BY OTHERS.

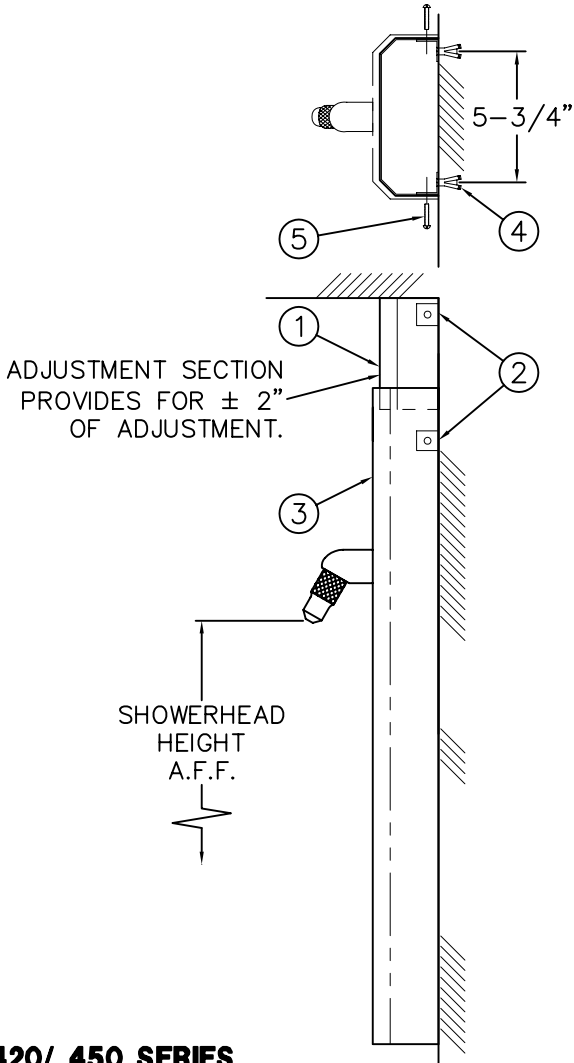

**420/ 450 SERIES**

**INSTALLATION INSTRUCTIONS (420/450 SERIES)**

AFTER COMPLETION OF TOP SUPPLY ROUGH-INS:

- A- POSITION ADJUSTMENT SECTION ① UP TO CEILING. USING ADJUSTMENT SECTION AS A TEMPLATE, MARK POSITION FOR L-CLIPS ②.
- B- FOLLOWING THE APPROPRIATE FIXTURE INSTALLATION INSTRUCTIONS, USE EXTENDED HOUSING ③ AS A TEMPLATE TO MARK POSITIONS FOR L-CLIPS ②.
- C- INSTALL WALL ANCHORS ④ (BY OTHERS) FOR L-CLIPS. POSITION L-CLIPS ② WITH CAGE NUT FACING OUTWARD FOR ATTACHMENT OF HOUSING AND FASTEN TO WALL (WALL FASTENERS BY OTHERS).
- D- ASSEMBLE ADJUSTMENT SECTION ① TO L-CLIPS USING #10-32 SCREWS ⑤ PROVIDED.
- E- COMPLETE FIXTURE INSTALLATION WITH HOUSING ② OVER ADJUSTMENT SECTION ①.

**NOTE:** FOR 420 SERIES SHOWERS (NOT SHOWN), CEILING ADJUSTMENT SECTION ASSEMBLES OVER HOUSING.

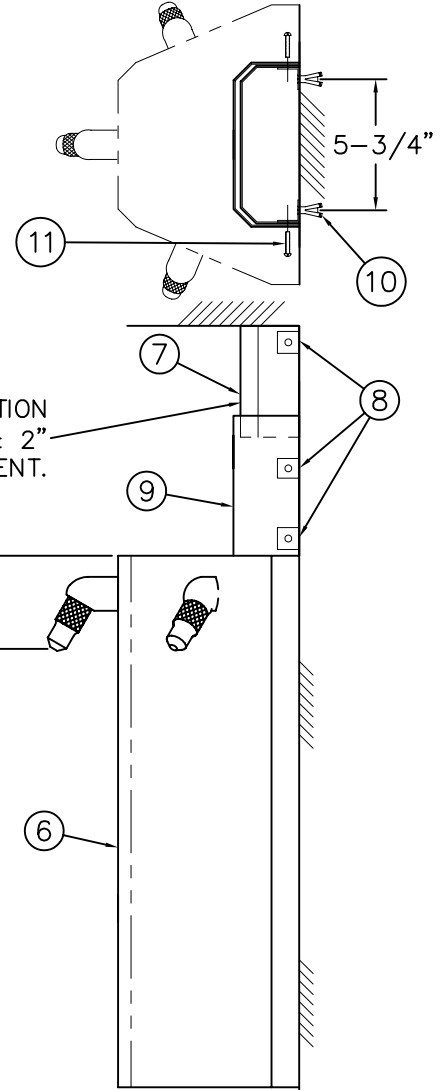

**460/ 470 SERIES**

**INSTALLATION INSTRUCTIONS (460/470 SERIES)**

AFTER COMPLETION OF TOP SUPPLY ROUGH-INS:

- A- MOUNT HOUSING ⑥ TO WALL PER APPROPRIATE FIXTURE INSTALLATION INSTRUCTIONS.
- B- POSITION ADJUSTMENT SECTION ⑦ UP TO CEILING. USING ADJUSTMENT SECTION AS A TEMPLATE, MARK POSITION FOR L-CLIPS ⑧.
- C- POSITION SUPPLY COVER ⑨ AND USE AS A TEMPLATE TO MARK POSITION FOR L-CLIPS ⑧.
- D- INSTALL WALL ANCHORS ⑩ (BY OTHERS) FOR L-CLIPS. POSITION L-CLIPS ⑧ WITH CAGE NUT FACING OUTWARD FOR ATTACHMENT OF HOUSING AND FASTEN TO WALL (WALL FASTENERS BY OTHERS).
- E- ASSEMBLE ADJUSTMENT SECTION ⑦ TO L-CLIPS USING #10-32 SCREWS ⑪ PROVIDED.
- F- ASSEMBLE SUPPLY COVER ⑨ TO L-CLIPS USING #10-32 SCREWS ⑪ PROVIDED.

<p>ACORN ENGINEERING COMPANY P.O. BOX 3527 INDUSTRY, CA. 91744 (626) 336-4561 FAX (626) 961-2200</p>	<p>TITLE <b>APEX OPTION -SC SUPPLY COVER for MODEL #420, #450, #460 &amp; #470</b></p>		
	<p>MANUFACTURE DATE</p> <p><b>JULY 1969</b></p> <p><b>TO PRESENT</b></p>	<p>DATE ISSUED</p> <p><b>10/05/92</b></p> <p>DATE REVISED</p> <p><b>06/22/04</b></p>	<p>DRAWING NUMBER</p> <p><b>9900-056-001</b></p>





BACK VIEW

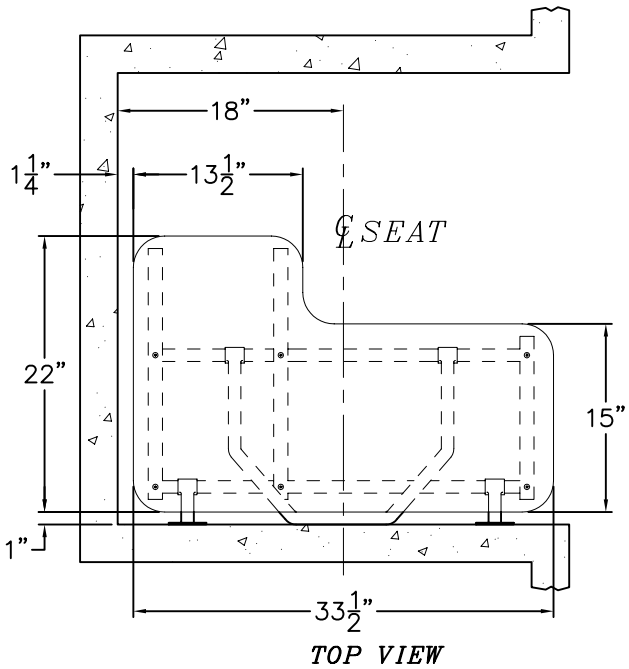
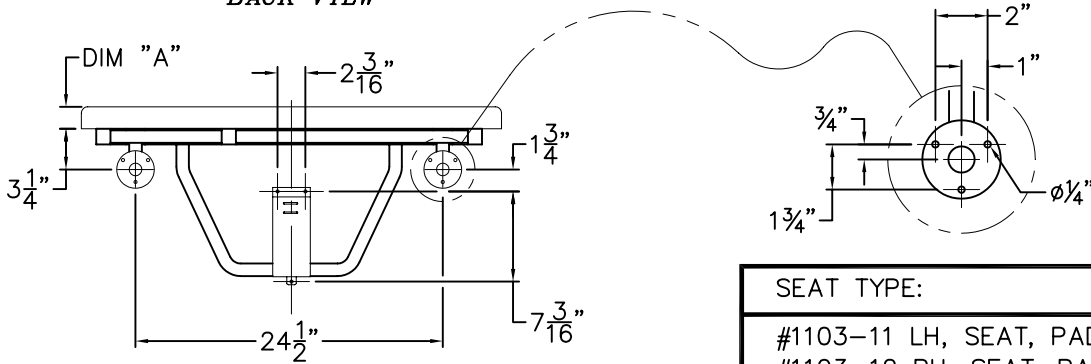

SEAT TYPE:	DIM 'A'
#1103-11 LH, SEAT, PADDED #1103-12 RH, SEAT, PADDED	3/4"
#1103-21 LH, SEAT, PHENOLIC #1103-22 RH, SEAT, PHENOLIC	1/2"
#1103-31 LH, SEAT, SS #1103-32 RH, SEAT, RH	1/8"

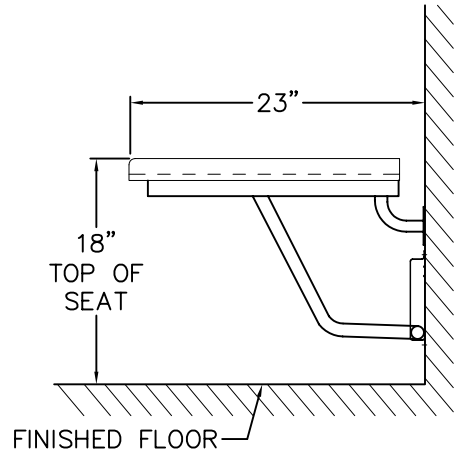

REFERENCE DRAWING	
-RD REINFORCED PANEL	9900-351-001

**INSTALLATION INSTRUCTIONS:**

A- USING FOLDED SEAT FRAME AS A TEMPLATE MARK HOLES ON WALL OR REINFORCED PANEL FOR MOUNTING FLANGES AND SUPPORT LEG GUIDE BRACKET FOR WALL ANCHORS AND ANCHORING HARDWARE BY OTHERS. FOR -RP PANEL MOUNTING, #10 x 1" LONG STAINLESS STEEL PHILIPS HEAD SHEET METAL SCREWS ARE RECOMMENDED. FOR WALL MOUNTING, #10 x 2" LONG STAINLESS STEEL PHILIPS HEAD SHEET METAL SCREWS ARE RECOMMENDED.

- B- SEAT SHOULD BE MOUNTED ON CENTER WITH 34" WIDE ACORN -RP REINFORCED PANEL. REFER TO PANEL DETAIL WITH JOB INSTALLATION INSTRUCTIONS FOR CUSTOM PANEL SIZE INFORMATION.
- C- THE SEAT IS PROPERLY INSTALLED IF IT FOLDS UP AND DOWN FREELY, YET STAYS IN THE UP POSITION WITHOUT ASSISTANCE.

CONSULT APPLICABLE CODES FOR SEAT HEIGHT & LOCATION REQUIREMENTS. RECOMMENDED SEAT HEIGHT IS 18" ABOVE FINISHED FLOOR.

IMPORTANT: THIS SHOWER SEAT IS INTENDED TO MEET OR EXCEED CURRENT ADA CODE REQUIREMENTS. SEAT REQUIRES ADEQUATE IN-WALL, WALL BACKING OR OTHER SECURE METHOD OF ANCHORING.



ACORN ENGINEERING COMPANY  
P.O. BOX 3527 INDUSTRY, CA. 91744  
(626) 336-4561 FAX (626) 961-2200

TITLE <b>FOLDING PADDED SEAT CATALOG * 1103 SERIES (A.D.A.)</b>		
MANUFACTURE DATE	DATE ISSUED	DRAWING NUMBER
<b>JANUARY 1, 1980</b>	<b>04/07/93</b>	<b>9900-350-001</b>
<b>TO PRESENT</b>	DATE REVISED	
	<b>09/13/10</b>	



SIDE OUTLET SHOWN

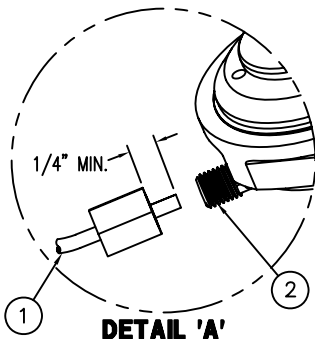

**DETAIL 'A'**

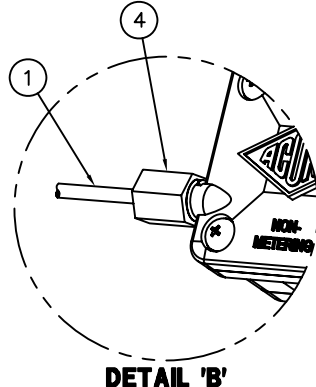

**DETAIL 'B'**

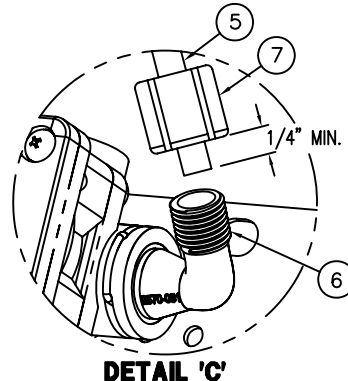

**DETAIL 'C'**

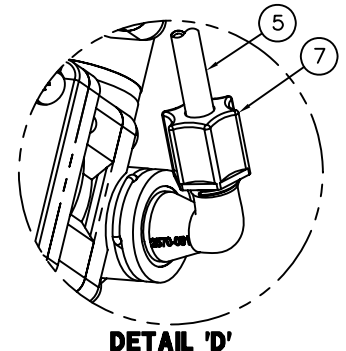

**DETAIL 'D'**

NOTE: PENAL-WARE & ECO-RAIN SHOWER FIXTURES USE 1/4" O.D. RISER TUBING WHILE OTHER SHOWER-WARE FIXTURES USE 3/8" O.D. TUBING.

AIR-CONTROL 03M-MA2 VALVE SHOWN FOR REFERENCE ONLY.

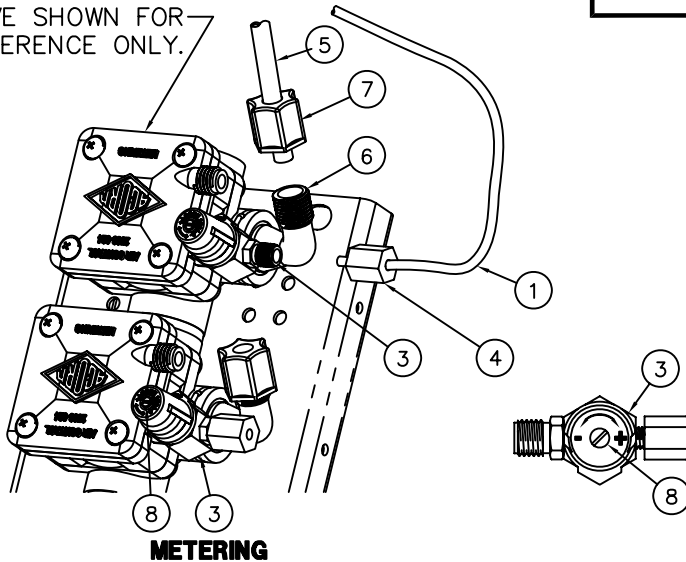

**METERING**

TIMING IS ADJUSTABLE FROM 5 TO 60 SECONDS AND IS ACCOMPLISHED BY ROTATING TIMING SCREW (8). TURNING THE TIMING SCREW CLOCKWISE INCREASES METERING TIME WHILE TURNING THE SCREW COUNTERCLOCKWISE DECREASES METERING TIME.

REFERENCE DRAWINGS	
REPAIR PARTS	DRAWING
VALVE BODY	9955-006-003
CHECKSTOP	9956-040-003
PUSHBUTTON/ESCUTCHEON	9957-300-001
METERING SERVOMOTOR	9955-000-003

NOTE:  
 • ALL TUBING SHOULD BE CUT SQUARE AND BE FREE OF BURRS OR DEFORMITIES TO ENSURE A WATER TIGHT CONNECTION.  
 • EXTEND TUBING AT LEAST 1/4" BEYOND FERRULE NUT AND INSERT TUBING INTO CONNECTION OPENING BEFORE TIGHTENING.  
 • TUBING SHOULD BE FREE OF KINKS TO ENSURE PROPER OPERATION.  
 • MAXIMUM RECOMMENDED WORKING WATER PRESSURE IS 100 PSI; TEMPERATURE IS 130° F; OUTLET TEMPERATURE IS RECOMMENDED AT A MAXIMUM OF 105° F.  
 WARNING:  
 PRIOR TO MAKING INSTALLATION, SUPPLY LINES MUST BE FLUSHED OF ALL FOREIGN MATERIAL SUCH AS PIPE DOPE, CHIPS, SOLDER, ETC. VALVE MUST BE DRAINED PRIOR TO BEING SUBJECTED TO FREEZING TEMPERATURES. MAXIMUM RECOMMENDED OUTLET WATER TEMPERATURE IS 105° F.

**INSTALLATION INSTRUCTIONS:**

- A- MOUNT FIXTURE IN ACCORDANCE TO MANUFACTURER'S INSTALLATION INSTRUCTIONS.
- B- ASSEMBLE PUSHBUTTONS AND OR SHOWER NOZZLES TO FIXTURE IF REQUIRED.
- C- CONNECT 1/8" O.D. POLYETHYLENE AIR LINE (1) TO PUSHBUTTON (2) AND VALVE TIMER ASSEMBLY (3). SEE DETAILS 'A' & 'B'. HAND TIGHTEN FERRULE NUT (4) PROVIDED.

- D- CONNECT SHOWER RISER (5) TO VALVE ASSEMBLY ELBOW (6). SEE DETAIL 'C' AND 'D'. HAND TIGHTEN FERRULE NUT (7) PROVIDED.
- E- AFTER THOROUGHLY FLUSHING SUPPLY LINES, MAKE UP CONNECTIONS TO VALVE ASSEMBLY INLET(S) 1/2" NPT OR 1/2" NPS FLEX HOSE AS REQUIRED.



ACORN ENGINEERING COMPANY  
 P.O. BOX 3527 INDUSTRY, CA. 91744  
 (626) 336-4561 FAX (626) 961-2200

TITLE <b>HAND OPERATED, AIR-CONTROL VALVE SHOWER CONNECTIONS</b>		
MANUFACTURE DATE	DATE ISSUED	DRAWING NUMBER
<b>OCTOBER 2010</b>	<b>10/28/10</b>	<b>9900-006-003</b>
<b>TO PRESENT</b>	DATE REVISED	



REFERENCE DRAWINGS	
ASSEMBLIES	NUMBER
T/P VALVE	9975-005-002

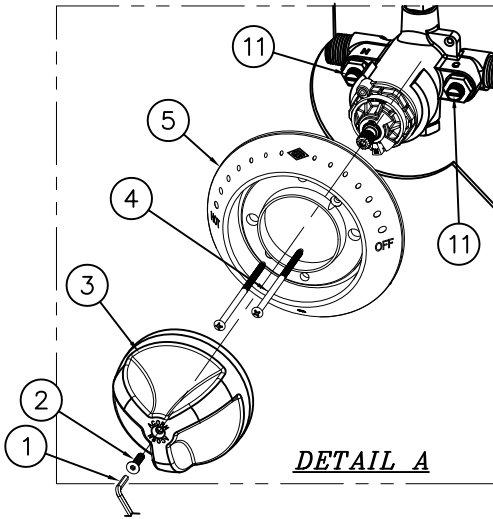

DETAIL A

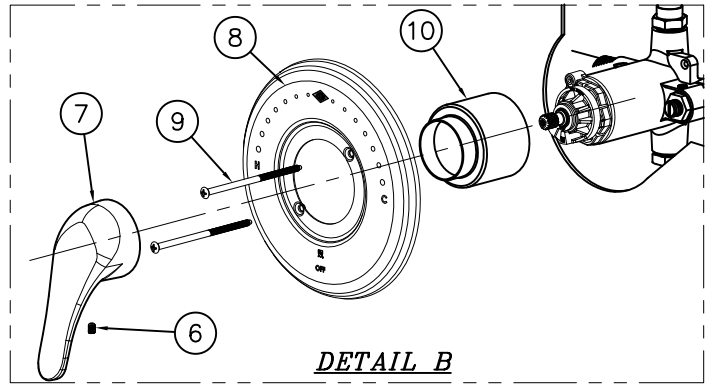

DETAIL B

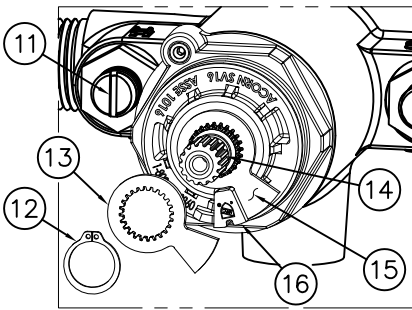

DETAIL C

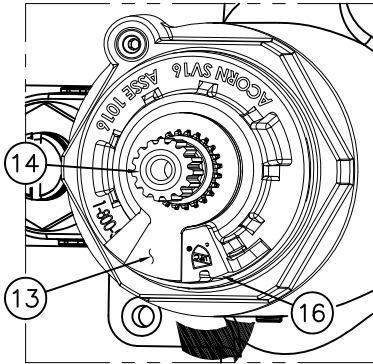

DETAIL D

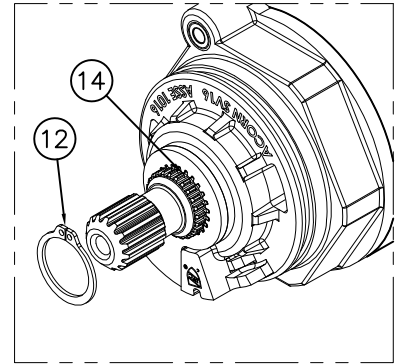

DETAIL E

**INSTRUCTIONS:**

A-REMOVE TRI-LEVER HANDLE TRIM: SEE DETAIL A

a- USING CENTER REJECT ALLEN WRENCH (1) REMOVE HANDLE SCREW (2) AND REMOVE HANDLE (3).

b- REMOVE ESCUTCHEON (4) BY REMOVING SCREWS (5).

FOR OPTIONAL -LVR LEVER HANDLE TRIM: SEE DETAIL B

a- REMOVE SET SCREW (6) AND HANDLE (7).

b- REMOVE ESCUTCHEON (8) BY REMOVING SCREWS (9).

c- PULL OFF VALVE SLEEVE (10).

**TEMPERATURE ADJUSTMENT:**

B-ENSURE MAIN WATER SUPPLY IS ON.

C-ENSURE CHECK STOPS (11) ARE OPEN.

D-ENSURE VALVE IS IN THE OFF POSTION.

E-USING SNAP RING PLIERS REMOVE RETAINING RING (12) AND THE FIRST TEMPERATURE LIMIT WASHER (13) ONLY FROM VALVE STEM (14). SEE DETAIL C.

NOTE: IF SECOND TEMPERATURE LIMIT WASHER (15) COMES OFF, RESETTING OF THE OFF STOP MAY BE REQUIRED, KEY AS CLOSE AS POSSIBLE ON THE COUNTER-CLOCKWISE SIDE OF BONNET STOP (16). USING HANDLE (3) OR (7) SLIGHTLY OPEN AND CLOSE VALVE TO ENSURE WATER WILL SHUT OFF. DETAIL C.

**TEMPERATURE ADJUSTMENT: CONTINUED:**

F- USING HANDLE (3) OR (7) TURN VALVE STEM (14) COUNTER-CLOCKWISE TO INCREASE HOT, CHECKING OUTLET TEMPERATURE UNTIL DESIRED TEMPERATURE IS REACHED (RECOMMENDED 105° TO 110°). SLIDE FIRST TEMPERATURE LIMIT WASHER (9) OVER VALVE STEM (13) AND ENSURE SIDE OF WASHER RESTS AS CLOSE AS POSSIBLE TO CLOCKWISE SIDE OF BONNET LIMIT STOP (16). DETAIL D.

G- WITH VALVE IN THE "ON" POSTION AND WATER RUNNING, USING SNAP RING PLIERS INSTALL RETAINING RING (12). ENSURE RETAINING RING (12) IS INSERTED PROPERLY INTO GROOVE ON VALVE STEM (14). DETAIL E.

H- REINSTALL TRIM IN REVERSE ORDER.



ACORN ENGINEERING COMPANY  
P.O. BOX 3527 Industry, CA 91744  
15125 Proctor Ave Industry, CA 91746  
(626) 336-4561 FAX (626) 961-2200

TITLE **-8 T/P TEMP/PRESS BALANCING MIXING VALVE - TEMPERATURE ADJUSTMENT**

MANUFACTURE DATE	DATE ISSUED	DRAWING NUMBER
<b>APRIL 2014</b>	<b>05/01/14</b>	
<b>PRESENT</b>	DATE REVISED	<b>9900-007-001</b>
	<b>09/01/16 B</b>	