

REFERENCE DRAWINGS

VALVE BODY	9955-006-003	ELECTRICAL COMPONENTS	
STOPS	9956-040-003	VALVE CONTROLLER	9955-025-001
FIXTURE TRIM	9957-300-001	SOLENOID VALVE	9955-020-002
SHOWER HEAD	9970-000-003	TRANSFORMER	9955-020-002
MOUNTING HDWR.	9957-900-001	WIRING COMPONENTS	9955-020-002
-SW SLEEVE/-MT TEMPLATE	9925-260-001		

NOTE:

- 1 - MAXIMUM RECOMMENDED WORKING WATER PRESSURE IS 100 PSI; TEMPERATURE IS 130°F; OUTLET TEMPERATURE IS RECOMMENDED AT A MAXIMUM OF 105°F.
- 2 - TRANSFORMER MUST BE WIRED TO A GFI PROTECTED CIRCUIT. FIXTURE MUST BE EARTH GROUNDED PER N.E.C. (NATIONAL ELECTRICAL CODE).

WARNING:

PRIOR TO MAKING INSTALLATION, SUPPLY LINES MUST BE FLUSHED OF ALL FOREIGN MATERIAL SUCH AS PIPE DOPE, CHIPS, SOLDER, ETC. VALVE MUST BE DRAINED PRIOR TO BEING SUBJECTED TO FREEZING TEMPERATURES.

NOTE:

**INSTALLATION REQUIRES THE USE OF AN APPROPRIATE CERTIFIED THERMOSTATIC MIXING VALVE PROVIDED BY OTHERS, PER APPLICABLE CODE.

INSTALLATION INSTRUCTIONS:

- A- PRIOR TO INSTALLATION OF THE SHOWER PANEL (1), MOUNT PUSHBUTTON (2) TO THE PANEL.
- B- HAND TIGHTEN (6) MOUNTING STUDS (3) INTO NUTS (4) ON THE BACK OF SHOWER PANEL (1). PLACE SHOWER PANEL AGAINST WALL OPENING. FROM CHASE SIDE, MOUNT BACK PLATES (5) ONTO STUDS; ATTACH WITH NUTS & WASHERS (6). NOTE: DO NOT EXCEED 6.5 FT/LBS MAXIMUM TORQUE ON MOUNTING NUTS (6).
- C- MOUNT SOLENOID VALVE ASSEMBLY (7) AS REQUIRED WITHIN 10 FEET OF THE FIXTURE. WALL FASTENERS BY OTHERS.
- D- MOUNT VALVE CONTROLLER (8) AS REQUIRED WITHIN 100 FEET OF THE PUSHBUTTON. CONNECT 1/8" O.D. POLYETHYLENE AIR LINE (9) FROM PUSHBUTTON (2) TO CONTROLLER (8) POSITION MARKED "ACTUATOR". HAND TIGHTEN THE FERRULE NUT AT PUSHBUTTON. SEE DETAIL "A".
- E- CONNECT 1/4" O.D. RISER TUBING (10) FROM SHOWER HEAD (11) TO VALVE ASSEMBLY (7) OUTLET. TIGHTEN THE FERRULE NUTS PROVIDED WATERTIGHT.

- H- CONNECT WIRES (12) (MARKED "VALVE") FROM CONTROLLER TO WIRES (13) FROM SOLENOID VALVE (14). ASSEMBLE USING THE WIRE CONNECTORS PROVIDED. EXTENSION WIRE MAY BE INCLUDED - IF ORDERED.
- I- CONNECT WIRES (15) FROM TRANSFORMER (24VAC) (16) TO VALVE CONTROLLER (8). ASSEMBLE USING WIRE CONNECTORS PROVIDED. EXTENSION WIRES FROM TRANSFORMER MAY BE INCLUDED - IF ORDERED.
- J- AFTER THOROUGHLY FLUSHING THE SUPPLY LINE, MAKE-UP SUPPLY CONNECTION (1/2" NPS FEMALE). THREAD FLEX CONNECTOR HOSE (17) FROM THE VALVE INLET TO SUPPLY STUB-OUT. (NOTE: THE SUPPLY INLET CONNECTION WILL ACCOMMODATE 1/2" NPT MALE ADAPTER.)
- K- SET TIMING ON THE VALVE CONTROLLER (8) AT DESIRED SETTING FOR FLOW DURATION.



ACORN ENGINEERING COMPANY
P.O. BOX 3527 Industry, CA 91744
15125 Proctor Ave Industry, CA 91746
(626) 336-4561 FAX (626) 961-2200

TITLE **PENAL-PAK WALL SHOWERS - SINGLE TEMP. TIME-TROL - LR/1741-MVC1**

MANUFACTURE DATE

**SEPT 1995
TO PRESENT**

DATE ISSUED

11/01/95

DATE REVISED

06/29/17 B

DRAWING NUMBER

9905-215-003

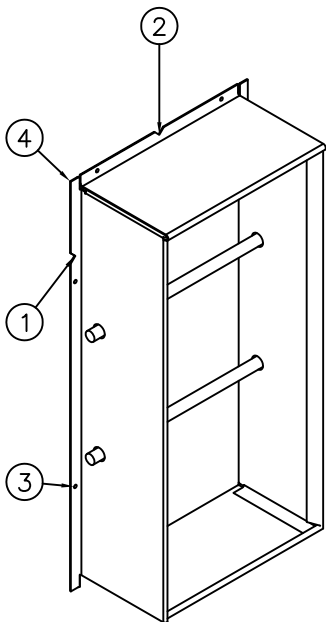
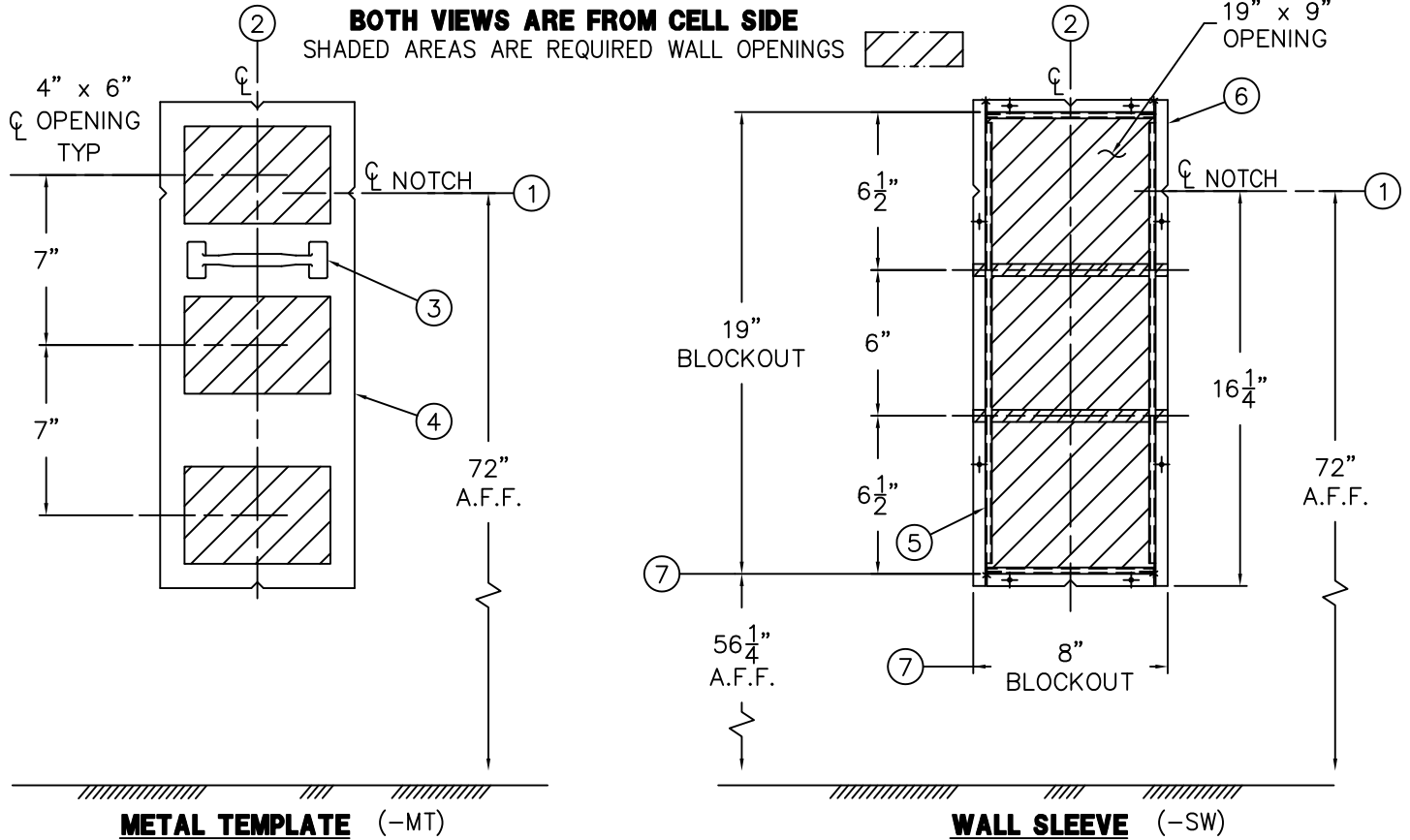

INSTALLATION INSTRUCTIONS:

METAL TEMPLATES (-MT)

TEMPLATES ARE USED TO LAYOUT REQUIRED WALL OPENINGS FOR SUBSEQUENT FLAME CUTTING OR CORE DRILLING.

- A- STRIKE A HORIZONTAL CHALKLINE (1) ON THE WALL 72" ABOVE FINISHED FLOOR. THIS WILL LOCATE CENTERLINE FOR HORIZONTAL NOTCHES ON TEMPLATE.
- B- STRIKE A VERTICAL CHALKLINE (2) ON THE WALL TO INDICATE CENTERLINE OF FIXTURE. THIS WILL LOCATE FOR VERTICAL NOTCHES ON TEMPLATE.
- C- USING HANDLE (3) ON TEMPLATE (4), PLACE TEMPLATE AGAINST THE WALL, LOCATING NOTCHES AT CHALKLINES. MARK FOR WALL OPENINGS.

WALL SLEEVES (-SW)

SLEEVES ARE INSTALLED IN FORMS (USING NAIL HOLES (5) PROVIDED) OR GROUTED INTO BLOCK WALLS, BECOMING A PERMANENT PART OF THE WALL.

NOTE: FOR POURED WALL CONSTRUCTION, TEMPORARY BRACING SHOULD BE INSTALLED WITHIN SLEEVE OPENING TO PREVENT DEFORMATION TO SLEEVE WHICH MAY OCCUR DURING POUR. DO NOT POUR CONCRETE DIRECTLY ON TOP OF WALL SLEEVE.

- A- INSTALL SLEEVE WITH FLANGE (6) ON CHASE SIDE OF WALL.
- B- TOP AND BOTTOM NOTCHES TO BE LOCATED AT VERTICAL CENTERLINE (2) OF SLEEVE.
- C- SIDE NOTCHES (1) TO BE LOCATED AT 72" ABOVE THE FINISHED CELL SIDE FLOOR (SHOWER HEAD DISCHARGE HEIGHT).
- D- WHEN SLEEVES ARE NOT AVAILABLE USE BLOCKOUT DIMENSIONS SHOWN (7).

ACORN ENGINEERING COMPANY
P.O. BOX 3527 Industry, CA 91744
15125 Proctor Ave Industry, CA 91746
(626) 336-4561 FAX (626) 961-2200

TITLE SLEEVES AND TEMPLATES (LR/1741-1 & LR/1741-3) SINGLE TEMP		
MANUFACTURE DATE JUNE 1971 TO PRESENT	DATE ISSUED 3-1-90	DRAWING NUMBER 9925-260-001
	DATE REVISED 06/29/17 B	



MVC1-MA2 WIRING DIAGRAM SHOWN FOR REFERENCE ONLY

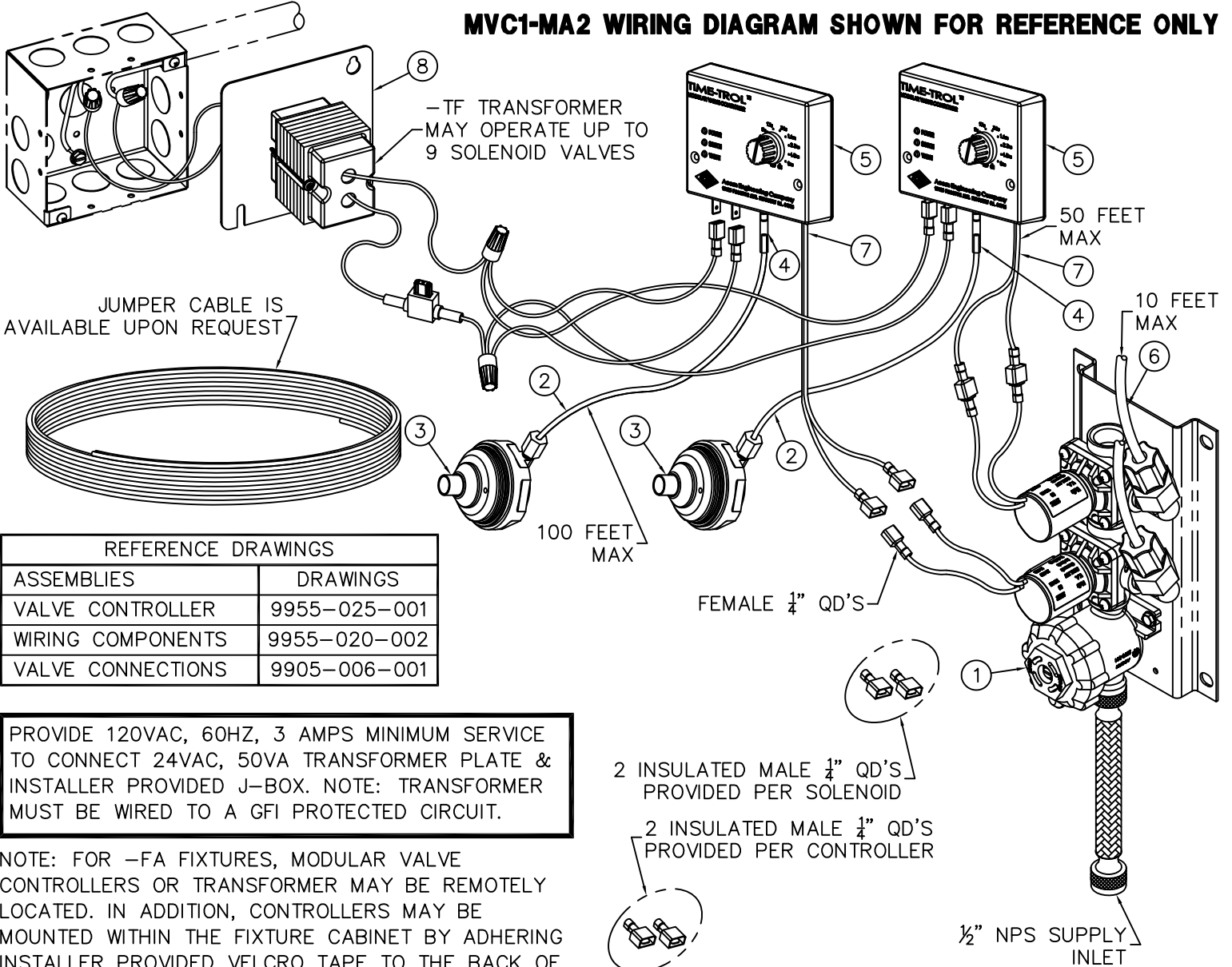

REFERENCE DRAWINGS	
ASSEMBLIES	DRAWINGS
VALVE CONTROLLER	9955-025-001
WIRING COMPONENTS	9955-020-002
VALVE CONNECTIONS	9905-006-001

PROVIDE 120VAC, 60HZ, 3 AMPS MINIMUM SERVICE TO CONNECT 24VAC, 50VA TRANSFORMER PLATE & INSTALLER PROVIDED J-BOX. NOTE: TRANSFORMER MUST BE WIRED TO A GFI PROTECTED CIRCUIT.

NOTE: FOR -FA FIXTURES, MODULAR VALVE CONTROLLERS OR TRANSFORMER MAY BE REMOTELY LOCATED. IN ADDITION, CONTROLLERS MAY BE MOUNTED WITHIN THE FIXTURE CABINET BY ADHERING INSTALLER PROVIDED VELCRO TAPE TO THE BACK OF THE CONTROLLER AND ONTO FIXTURE CABINET.

INSTALLATION INSTRUCTIONS:

- A- ROUGH-IN & INSTALL FIXTURE PER MANUFACTURER'S INSTRUCTIONS.
- B- MOUNT SOLENOID VALVE ASSEMBLY (1) WITHIN THE CHASE OR FIXTURE FRAME / CABINET AS REQUIRED A MAXIMUM OF 10 FEET FROM THE FIXTURE.
- C- CONNECT AIR TUBING (2) TO MOUNTED PUSHBUTTON ASSEMBLY (3) AND HAND TIGHTEN FERRULE NUT. CONNECT THE TAG END OF THE AIR TUBING (2) TO THE VALVE CONTROLLER TUBE (4) AT THE POSITION MARKED "ACTUATOR" ON THE CONTROLLER (5). AIR TUBING FITS INSIDE THE CONTROLLER TUBE (4).

- D- CONNECT RISER TUBING (6) TO VALVE ASSEMBLY AND FIXTURE DISCHARGE CONNECTOR. HAND TIGHTEN USING FERRULE NUTS PROVIDED.
- E- CONNECT CONTROLLER WIRES (7) (INDICATED AS "VALVE" ON THE CONTROLLER) FROM VALVE CONTROLLER (2) TO SOLENOID VALVE (1).
- F- MAKE UP CONNECTIONS FROM TRANSFORMER (8) TO CONTROLLERS IN PARALLEL AS SHOWN.
- G- AFTER THOROUGHLY FLUSHING SUPPLY LINES MAKE UP SUPPLY CONNECTIONS.
- H- SET TIMING ON VALVE CONTROLLER (5) TO DESIRED FLOW DURATION.

<p>ACORN ENGINEERING COMPANY P.O. BOX 3527 Industry, CA 91744 15125 Proctor Ave Industry, CA 91746 (626) 336-4561 FAX (626) 961-2200</p>	<p>TITLE MVC1-MA2 TIME-TROL SINGLE TEMP VALVE INSTALLATION</p>		
	<p>MANUFACTURE DATE</p> <p>MAY 1990</p> <p>TO PRESENT</p>	<p>DATE ISSUED</p> <p>08/05/10</p>	<p>DRAWING NUMBER</p> <p>9900-001-004</p>
		<p>DATE REVISED</p> <p>01/11/13</p>	



EVS1-MA2 SHOWN FOR REFERENCE ONLY

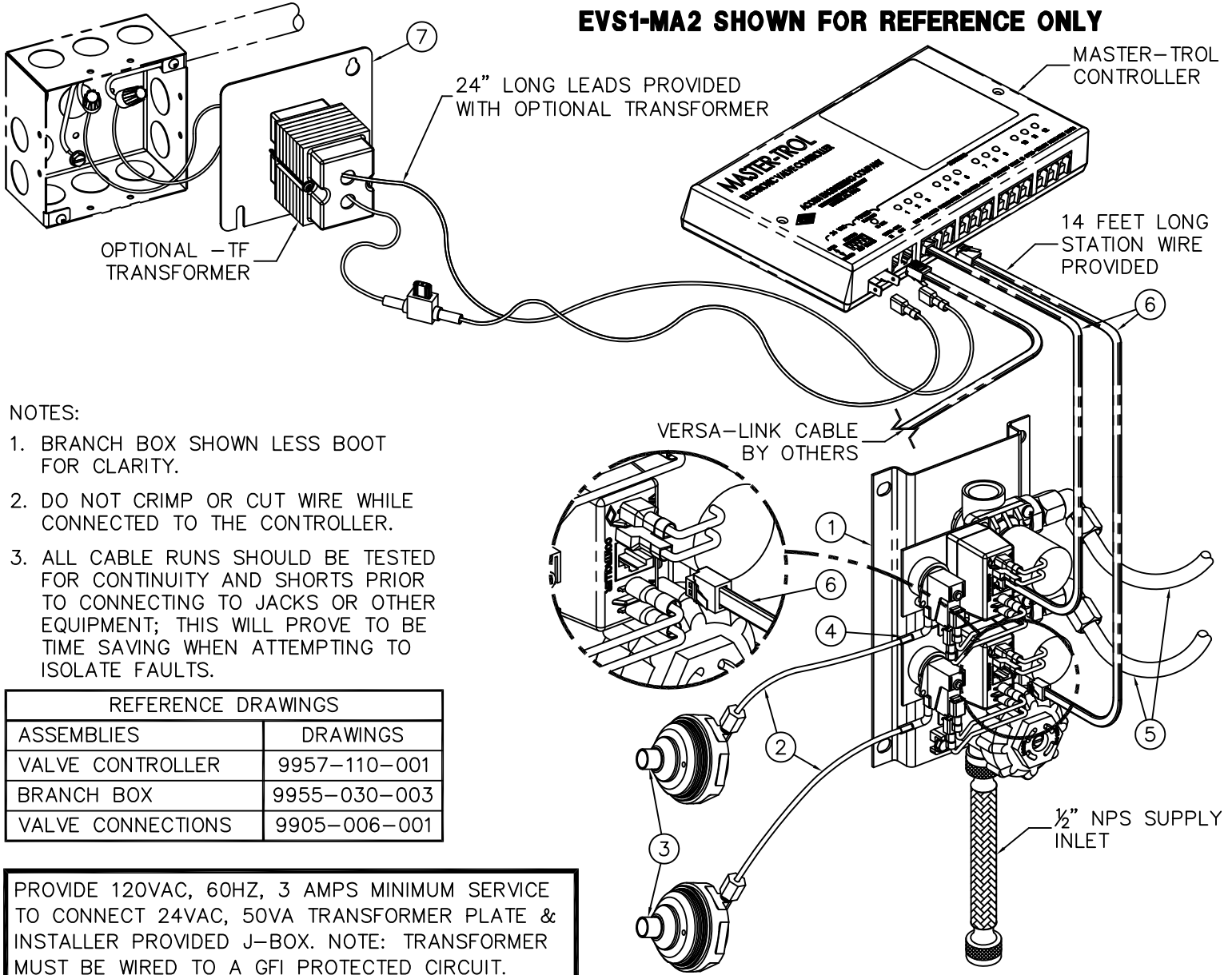

NOTES:

1. BRANCH BOX SHOWN LESS BOOT FOR CLARITY.
2. DO NOT CRIMP OR CUT WIRE WHILE CONNECTED TO THE CONTROLLER.
3. ALL CABLE RUNS SHOULD BE TESTED FOR CONTINUITY AND SHORTS PRIOR TO CONNECTING TO JACKS OR OTHER EQUIPMENT; THIS WILL PROVE TO BE TIME SAVING WHEN ATTEMPTING TO ISOLATE FAULTS.

REFERENCE DRAWINGS	
ASSEMBLIES	DRAWINGS
VALVE CONTROLLER	9957-110-001
BRANCH BOX	9955-030-003
VALVE CONNECTIONS	9905-006-001

PROVIDE 120VAC, 60HZ, 3 AMPS MINIMUM SERVICE TO CONNECT 24VAC, 50VA TRANSFORMER PLATE & INSTALLER PROVIDED J-BOX. NOTE: TRANSFORMER MUST BE WIRED TO A GFI PROTECTED CIRCUIT.

INSTALLATION INSTRUCTIONS:

- A. ROUGH-IN & INSTALL FIXTURE PER MANUFACTURER'S INSTRUCTIONS.
- B. MOUNT SOLENOID VALVE ASSEMBLY (1) WITHIN THE CHASE OR FIXTURE FRAME / CABINET AS REQUIRED A MAXIMUM OF 10 FEET FROM THE FIXTURE.
- C. CONNECT AIR TUBING (2) TO MOUNTED PUSHBUTTON ASSEMBLY (3) AND HAND TIGHTEN FERRULE NUT. CONNECT THE TAG END OF THE AIR TUBING (2) TO THE BRANCH BOX PRESSURE SWITCH 3/16" OD TUBE (4). AIR TUBING (2) FITS INSIDE THE PRESSURE SWITCH 3/16" OD TUBE (4).
- D. CONNECT RISER TUBING (5) TO VALVE ASSEMBLY AND FIXTURE DISCHARGE CONNECTOR. HAND TIGHTEN USING FERRULE NUTS PROVIDED.
- E. CONNECT STATION WIRE (6) TO BRANCH BOX AND APPROPRIATE LOCATION ON CONTROLLER.
- F. MAKE UP CONNECTIONS FROM TRANSFORMER (8) TO CONTROLLER AS SHOWN.
- G. AFTER THOROUGHLY FLUSHING SUPPLY LINES MAKE UP SUPPLY CONNECTIONS.

<p>ACORN ENGINEERING COMPANY P.O. BOX 3527 Industry, CA 91744 15125 Proctor Ave Industry, CA 91746 (626) 336-4561 FAX (626) 961-2200</p>	<p>TITLE EVS1 MASTER-TROL SINGLE TEMP VALVE INSTALLATION</p>		
	<p>MANUFACTURE DATE</p> <p>MAY 1998</p> <p>TO PRESENT</p>	<p>DATE ISSUED</p> <p>12/09/10</p> <hr/> <p>DATE REVISED</p> <p>05/14/13</p>	<p>DRAWING NUMBER</p> <p>9905-330-004</p>



TWO STATION AND ADA WIRING DIAGRAM SHOWN

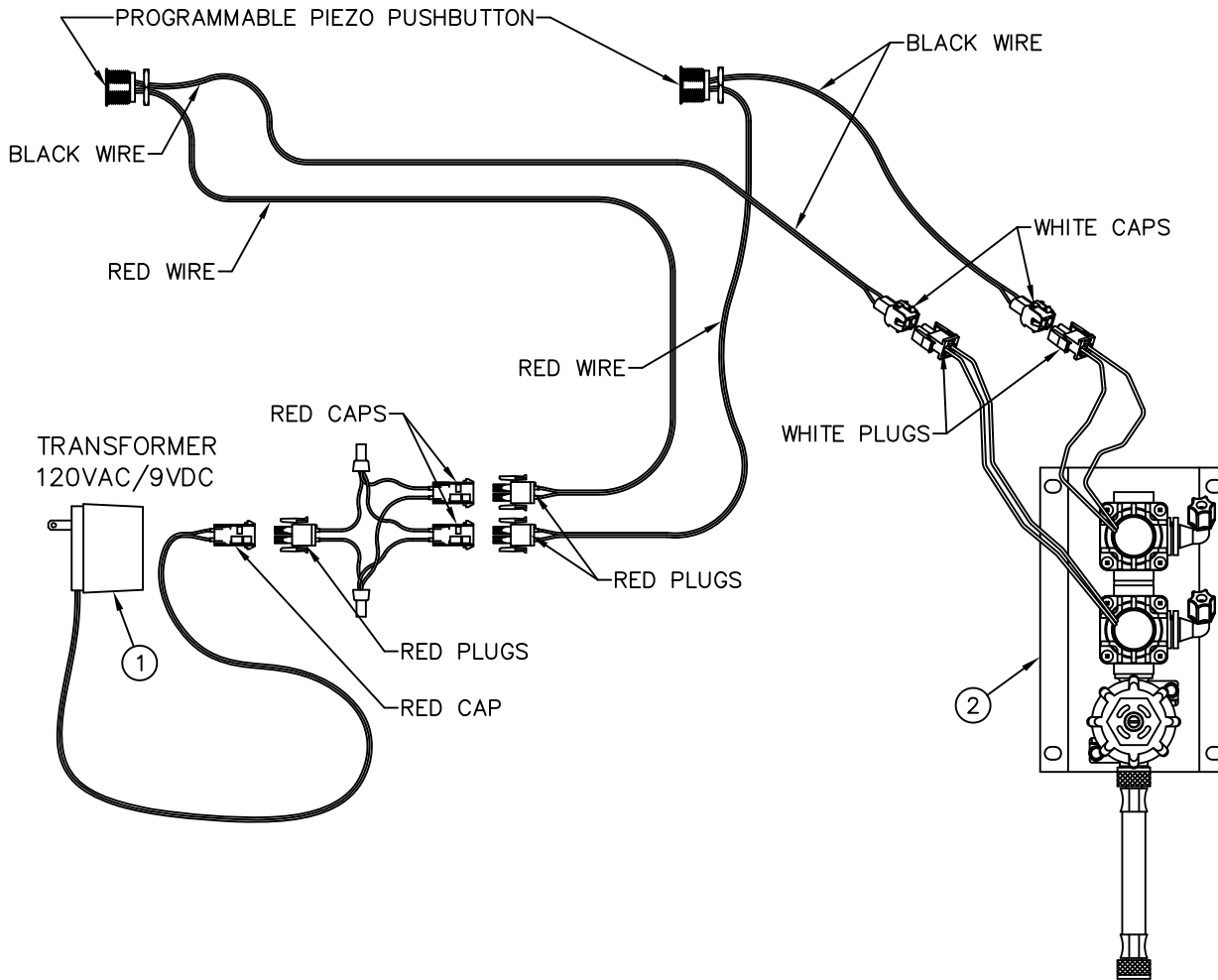

REFERENCE DRAWINGS	
9VDC SENSOR & PARTS	9955-019-002
PIEZO PB PROGRAMMING	9940-009-001

INSTALLATION INSTRUCTIONS:

A- USING APPROPRIATE INSTALLATION INSTRUCTIONS, MOUNT FIXTURE TO WALL AND MAKE-UP SUPPLY CONNECTIONS. ELECTRONIC PUSHBUTTON ARE FACTORY INSTALLED. POWER SUPPLY ① AND VALVE ② SHIPPED LOOSE.

B- INSTALL SOLENOID VALVE ASSEMBLY ② ON THE WALL (FASTENERS AND WALL ANCHORS BY OTHERS), MAKING SURE THAT THE VALVE WILL BE WITHIN HOUSING OR BLOCKOUT AREA.

C- CONNECT WATER SUPPLY (AFTER FLUSHING LINES) TO VALVE, AND VALVE RISER TO SHOWERHEAD AS PER UNIT INSTALLATION INSTRUCTIONS.

D- CONNECT SOLENOID VALVE, POWER SUPPLY AND SENSOR WIRING AS SHOWN ON DETAIL.

E- COMPLETE THE INSTALLATION OF THE UNIT ACCORDING ACORDING TO THE UNITS INSTALLATION INSTRUCTIONS.

NOTE:

1- PLUG-IN TRANSFORMER INCLUDES BUILT-IN SECONDARY FUSE. IN THE EVENT OF POWER SURGE TRANSFORMER MAY REQUIRE REPLACEMENT.

2- ELECTRICAL RECEPTACLE MUST BE WIRED TO A GFI PROTECTED CIRCUIT. FIXTURE MUST BE EARTH GROUNDED PER N.E.C. (NATIONAL ELECTRICAL CODE).



ACORN ENGINEERING COMPANY
P.O. BOX 3527 Industry, CA 91744
15125 Proctor Ave Industry, CA 91746
(626) 336-4561 FAX (626) 961-2200

TITLE -PPZ PIEZO ELECTRONIC PUSHBUTTON INSTALLATION		
MANUFACTURE DATE OCTOBER 2013 TO PRESENT	DATE ISSUED 10/11/13	DRAWING NUMBER 9927-223-001
	DATE REVISED	



Programable Piezo Pushbutton Programming Instructions (Flow Time Adjustment)

The Button is factory set an 8 sec. timing cycle, if an 8 sec. cycle is adequate, then **no** programming adjustment is required. This will provide less than 1/4 gallon (1 liter) per run cycle. If is noted that the valves are running longer than this maximum recommended cycle time please follow these instructions to correct the cycle time. When properly set the faucet should not produce more than 1/4 gallon (1 liter) per cycle. Pushing button during the timing cycle will stop the cycle (Cycle Interrupt).

 NOTE: Read the entire document before trying to program the piezo pushbutton.*

THE TIME SETTINGS PROGRAM USES 3 DIFFERENT TIMING MODES:

- **1 second timing mode:** Each push of the button adds 1 second to the total timing cycle.
- **5 second timing mode:** Each push of the button adds 5 seconds to the total timing cycle.
- **20 second timing mode:** Each push of the button adds 20 seconds to the total timing cycle.

To program the piezo pushbutton, you will need to be able to see the back of the piezo pushbutton.

Prevision must be made to access the back of the piezo pushbutton. There is an LED on the back of the piezo pushbutton under a layer of transparent epoxy, used as a programming indicator light (see page 3).

 NOTE: This programming procedure moves along rapidly, there is only about 2 or 3 seconds between programming operations.

In order to start the programming the piezo pushbutton, the button must be powered down. Disconnect the red power cable and wait 20 seconds, then reconnect the red power cable.

As soon as the cable is reconnected the LED will start flashing, it will flash 4 times, then stays on for 3 seconds. During the 3 second period, push the piezo button once, the LED will go out, now you are in the **1 sec timing mode** and each time the button is pushed the LED will flash, adding 1 sec to the total timing cycle.

To move on to the **5 sec timing mode**, pause and wait for the LED to flash 2 times, now you are in the 5 sec timing mode. Each time the button is pushed the LED will flash, adding 5 sec to the total timing cycle.

To move on to the **20 sec timing mode**, pause and wait for the LED to flash 3 times, now you are in the 20 sec timing mode and each time the button is pushed the LED will flash, adding 20 sec to the total timing cycle. After programing is complete, pause and wait for the LED to flash 4 times and then 5 times, which completes the programming.

GENERAL NOTES:

- When a **timing mode is not required** then **do not** push the button and wait for the next timing mode.
- Each timing mode (1 sec, 5 sec or 20 sec timing mode) can be sequenced up to 100 times, that is the number of times, the button can be pushed, to increase the total timing cycle in each timing mode.

*See work sheet on page 2 which will simplify the programming procedure.



Please visit www.acorneng.com for most current specifications.

Programmable Piezo Pushbutton Programming Instructions (Flow Time Adjustment)

WORKSHEET

(FILL IN ALL BOXES, WHICH WILL SIMPLIFY THE PROGRAMMING PROCEDURE)

Fill in all the Boxes below
↓ ↓

PROGRAMING STEPS:

- Power down piezo button for 20 seconds.
- Reconnect power.
- LED flashes, then stays on.
- While the LED is steady on, push button.
- LED turns off.

Determine the number of seconds per timing cycle

1 Push = 1 Second
 x 1 = sec



- You are in the 1 sec timing mode, immediately push the button, 1 push equals 1 sec added to the total timing cycle.
- Pause and wait for the LED to flash 2 times.

ADD ↑↓

1 Push = 5 Seconds
 x 5 = sec



- You are in the 5 sec timing mode, immediately push the button, 1 push equals 5 sec added to the total timing cycle.
- Pause and wait for the LED to flash 3 times.

ADD ↑↓

1 Push = 20 Seconds
 x 20 = sec



- You are in the 20 sec timing mode, immediately push the button, 1 push equals 20 sec added to the total timing cycle.

EQUALS ↓

Total timing cycle equals
 seconds

NOTE: if you miss a step in the programming procedure, just power down the button and start again from the first step.



INSTALLATION, OPERATIONS & MAINTENANCE MANUAL

Please visit www.acorneng.com for most current specifications.

