

REFERENCE DRAWINGS	
1810, 1812 -SW Wall Sleeve	9925-292-001
Mounting Hardware	9957-900-001

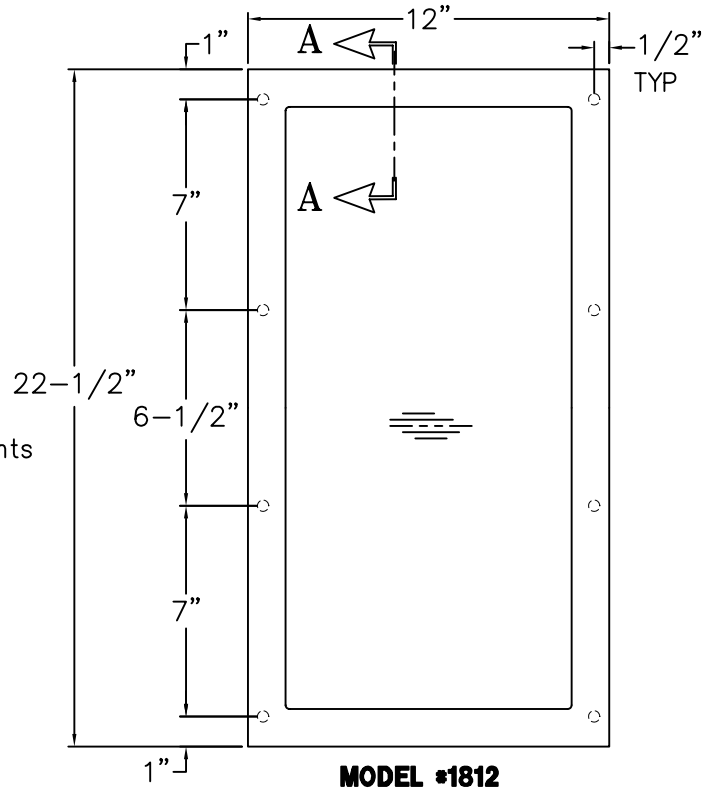
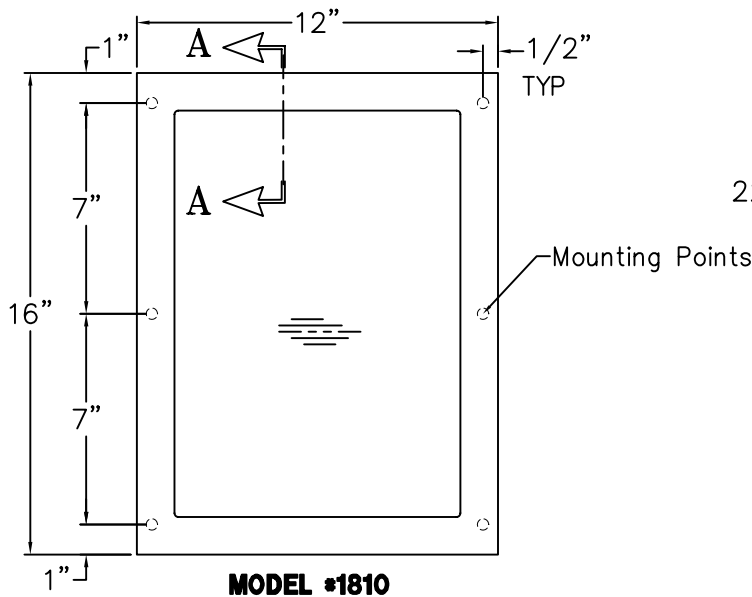

INSTALLATION INSTRUCTIONS:

- A- HAND TIGHTEN 1/4"-20 UNC STUDS ① INTO MOUNTING NUTS ② ON BACK OF MIRROR FRAME ③.
- B- POSITION MIRROR ④ AND WOOD PLANKS (2) ⑤ INTO FRAME WITH MIRROR CENTERED IN FRAME.
- C- POSITION MIRROR ASSEMBLY ③ ON CELL SIDE, SLIDING STUDS ① THROUGH SLEEVE OR WALL OPENINGS.

- D- FROM CHASE SIDE PLACE WASHERS ⑥ AND NUTS ⑦. PROVIDED ONTO STUDS AND TIGHTEN.
- NOTE:** DO NOT EXCEED 6.5 FT/LBS MAXIMUM TORQUE ON 1/4"-20 NUTS ⑦.



ACORN ENGINEERING COMPANY
P.O. BOX 3527 INDUSTRY, CA. 91744
(626) 336-4561 FAX (626) 961-2200

TITLE		
REAR MOUNTED SECURITY MIRRORS, CAT #1810 & #1812		
MANUFACTURE DATE	DATE ISSUED	DRAWING NUMBER
DECEMBER 1971 TO PRESENT	11/20/96	
	DATE REVISED	9925-132-001
	04/26/10	



BOTH VIEWS ARE FROM CELL SIDE

SHADED AREAS ARE REQUIRED WALL OPENINGS

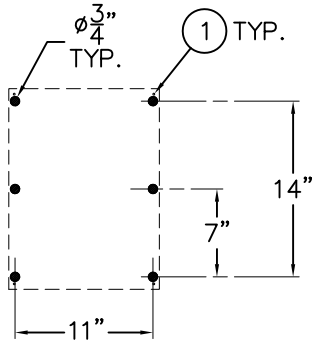

CAT. #1810

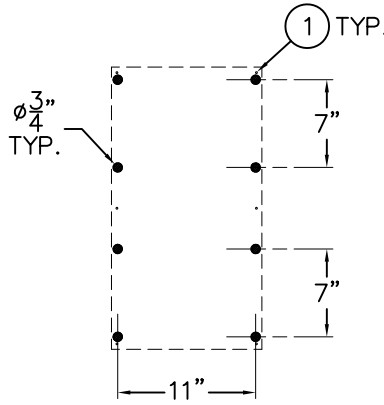

CAT. #1812

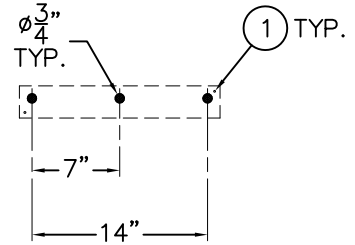

CAT. #1821 & 1822

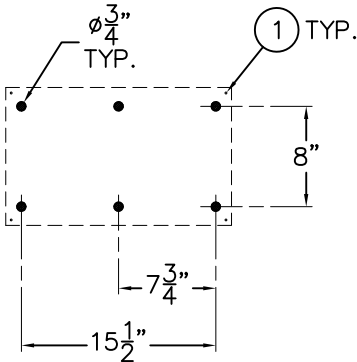

CAT. #1823

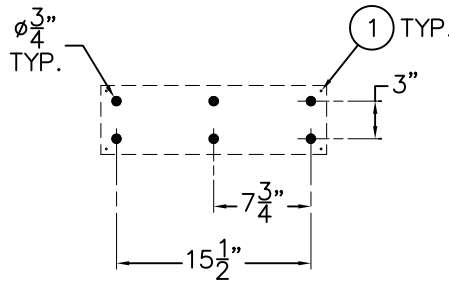

CAT. #1825 & 1827

INSTALLATION INSTRUCTIONS:

SLEEVES ARE INSTALLED IN FORMS USING NAIL HOLES (1) PROVIDED OR GROUTED INTO BLOCK WALLS BECOMING A PERMANENT PART OF THE WALL.

NOTE: FOR POURED WALL CONSTRUCTION, TEMPORARY BRACING SHOULD BE INSTALLED WITHIN OPENING TO PREVENT DEFORMATION TO SLEEVE WHICH MAY OCCUR DURING POUR. DO NOT POUR CONCRETE DIRECTLY ON TOP OF WALL SLEEVE. THE OPENINGS ARE CAPPED; THESE CAPS (2) MUST BE REMOVED FROM THE CHASE SIDE OF THE WALL SLEEVE BEFORE INSTALLING FIXTURE.

A- INSTALL SLEEVE AT DESIRED CELL SIDE HEIGHT WITH FLANGE (3) ON CHASE SIDE OF WALL.

B- WHEN SLEEVES ARE NOT AVAILABLE BLOCKOUT WITH DIMENSIONS SHOWN.

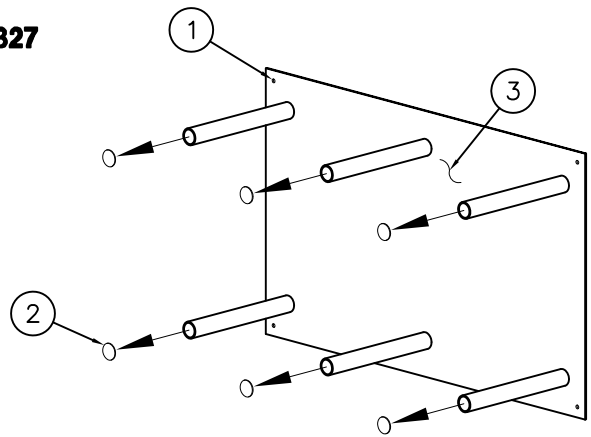

*#1823 SHOWN FOR REFERENCE
SCALED x 2*

ACORN ENGINEERING COMPANY P.O. BOX 3527 Industry, CA 91744 15125 Proctor Ave Industry, CA 91746 (626) 336-4561 FAX (626) 961-2200	TITLE WALL SLEEVES (CAT. #1810, 1812, 1821, 1822, 1823 & 1825)		
	MANUFACTURE DATE DECEMBER 1971 TO PRESENT	DATE ISSUED 03/01/90	DRAWING NUMBER 9925-292-001
	DATE REVISED 10/30/12		