

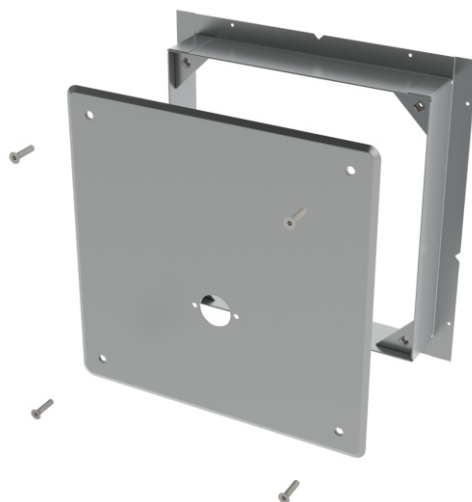

Dura-Ware® 2898 Series Flush Valve Access Panel



2898

Fixture May Show Some Available Options

Please visit www.acorneng.com for most current specifications.

Flush Valve Access Panel

The **Acorn Flush Valve Access Panel** is recommended for flushing conventional toilets, urinals and floor drains with concealed flush valve connections. The Flush Valve Access Panel design provides easy access to an installer provided concealed flush valve when no access is provided behind the wall.

Mounting Frame is welded construction and is fabricated of 20 gage galvanized steel for walls 2" (50mm) minimum to 12" (305mm) maximum thick. The front of the mounting frame has a reinforcing hem and is provided with corner braces with panel anchoring nuts provided. The rear of the mounting flange includes a flange and is provided with nail holes to secure the frame to forms or wall construction.

Removable Access Panel cover is fabricated of 14 gage type 304 stainless steel with beveled edges and exposed surfaces having a satin finish and is secured to mounting frame with four 1/4" tamper-resistant stainless steel screws. Panel includes a 1-1/2" diameter hole punching for an appropriate installer provided flush valve pushbutton assembly for either wall box or access panel type installations.

GUIDE SPECIFICATION

Provide and install an Acorn Flush Valve Access Panel frame fabricated of 20 gage galvanized steel with 14 gage panel cover. All exposed stainless steel surfaces shall have a satin finish. Flush valve provided by others shall be pushbutton operated with panel cover secured with stainless steel vandal resistant fasteners. Mounting hardware, flush valve, and piping shall be by others.



Dura-Ware® 2898: Flush Valve Access Panel

MODEL OF FIXTURE FOR APPLICATION: _____

PRODUCT OPTIONS

-EG Enviro-Glaze Color, Specify: _____

WALL THICKNESS AND TYPE (Must Specify)

Thickness: _____ Type: Concrete Block Steel

MODEL NUMBER AND OPTIONS SELECTION

BASE MODEL NUMBER

2898 Flush Valve Access Panel

Flush Valve Type (Must Specify)

-Electronic (Acorn Style "D" Punching)

-Electronic Valve by Others

Size _____ Shape _____

-Hydraulic

-Mechanical

Please visit www.acorneng.com
for most current specifications.

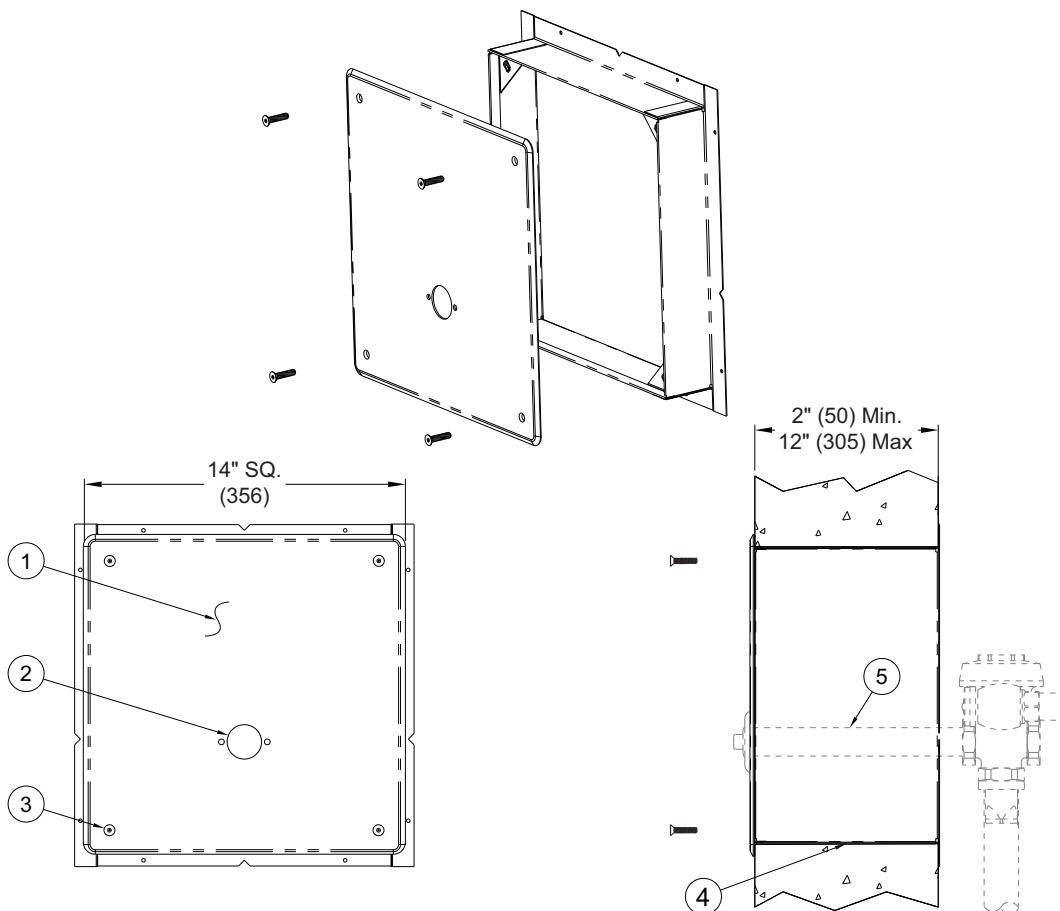

MODEL #2898

NOTES:

1. Removable Stainless Steel Panel.
2. 1-1/2" Punching for Flush Valve Pushbutton By Others.
3. Tamper Resistant Screws.

4. Wall Mounting Frame.
5. Mechanical Push Button Actuator (Shown For Reference Only)

WARNING: Cancer and Reproductive Harm - www.P65Warnings.ca.gov

Important: Installation instructions and current rough-in are furnished with each fixture. Do not rough in without certified dimensions. Dimensions are subject to manufacturer's tolerance of plus or minus 1/4" and change without notice. Acorn assumes no responsibility for use of void or superseded data. © Copyright 2010 Acorn Engineering Company

<p style="text-align: center;">Selection Summary</p> <p>Model No. & Option _____</p> <p>Quantity _____</p>	<p style="text-align: center;">Approved for Manufacturing</p> <p>Company _____ Title _____</p> <p>Signature _____ Date _____</p>
--	--