



Wash-Ware® 3351 Series

Retro-Pak - Replacement



Fixture May Show Some Available Options

Please visit www.acorneng.com for most current specifications.

Retro-Pak Replacement

The Acorn Retro-Pak has been designed to completely replace the operating mechanism on Bradley HC model Washfountains.

BRADLEY MODELS: CHC 554, CHC 536, KHC 5541*

The Acorn Retro-Pak replaces the sprayhead, soap dispensing system and valve assembly. The Retro-Pak sprayhead and stanchion assembly is fabricated entirely of type 304 stainless steel with a satin finish. Acorn's sprayhead is designed to contain the pushbuttons, individual spray nozzles and optional soap system. The sprayhead assembly is mounted to the existing bowl, using tie rods and supporting castings. Gasket for applicable bowl material is included.

The Valve Assembly, including the single handle pressure balancing mixing valve and the individual, non-hold open metering valves are arranged to be located within the existing pedestal. A mounting bracket is included to accommodate wall or floor mounting.

Valves are Air-Control pneumatically operated, pushbutton type using atmospheric air. Pushbutton is vandal-resistant and requires less than 5 pounds to activate valve. Valve is metering type with non-hold open feature. Timing is adjustable from 5 to 60 seconds.

Regularly furnished items include sprayhead, sprayhead stanchion, upper and lower support castings, tie rods, gasket, pressure balancing mixing valve, strainer checks, and Air-Control metering valves (one per washing station).

GUIDE SPECIFICATION

Provide and install Acorn Retro-Pak (specify model number and options) with individual Air-Control non-hold open metering valves and spray nozzles. Sprayhead and stanchion to be type 304 stainless steel with a satin finish.

* These models are registered trademarks of Bradley Corporation.



Wash-Ware®: 3351 Retro-Pak - Replacement

REPLACEMENT WASHFOUNTAIN DESCRIPTION (Must Specify)

- Configurations:** Semi-Circular Corner
- Number of Users:** 4 3 2
- Supplies:** From Above From Below
- Vent:** Centrally Rising Off Drain

PRODUCT OPTIONS (Must Specify)

- DV Liquid / Lotion Soap Dispenser
- PDM Metering Liquid Soap Dispenser
- SC Supply Vent Cover Ceiling
Height: _____
- ST Single Temperature Supply

MODEL NUMBER AND OPTIONS SELECTION

BASE MODEL NUMBER

- 3351 Retro-Pak (For Replacing Bradley HC Models)

OPERATION (Must Specify)

- H Hand Operation
- SO Sensor Operation
- SO-BAT Sensor Operated, Battery Powered (Batteries Not Included)

Please visit www.acorneng.com for most current specifications.

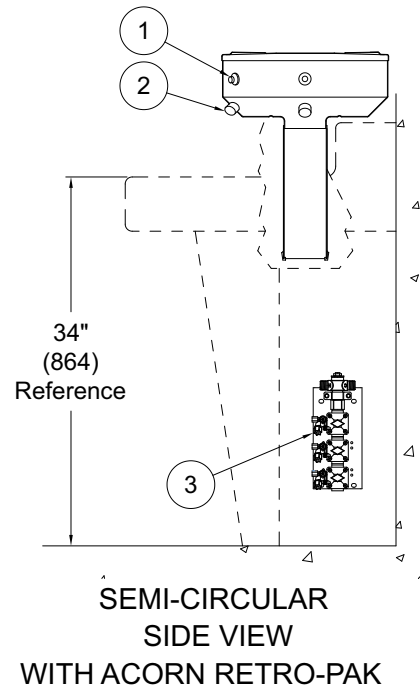
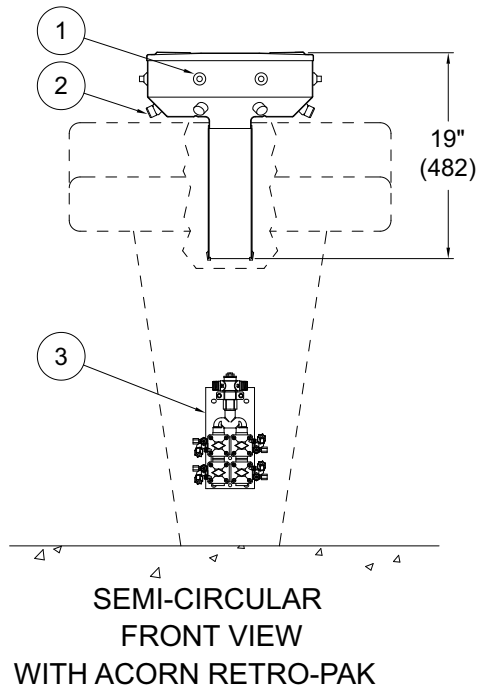

MODEL# 3351-H

Series

3. Valve Assembly.

NOTES:

1. Valve Pushbuttons.
2. Spray Nozzles.

WARNING: Cancer and Reproductive Harm - www.P65Warnings.ca.gov

<p>Important: Installation instructions and current rough-in are furnished with each fixture. Do not rough in without certified dimensions. Dimensions are subject to manufacturer's tolerance of plus or minus 1/4" and change without notice. Acorn assumes no responsibility for use of void or superseded data. © Copyright 2004 Acorn Engineering Company</p>	
<p>Selection Summary</p> <p>Model No. & Option _____</p> <p>Quantity _____</p>	<p>Approved for Manufacturing</p> <p>Company _____ Title _____</p> <p>Signature _____ Date _____</p>