



## Wash-Ware® 3601 Series

Acorn Terrazzo Uni-Lav - 1 Station - ADA Compliant



3601-1-H

Fixture May Show Some Available Options

Please visit [www.acorneng.com](http://www.acorneng.com) for most current specifications.

### Acorn Terrazzo Uni-Lav - 1 Station - ADA Compliant

**Bowl and Sprayhead** are reinforced cast Terrazzo. Bowl is 20-3/8" (518mm.) wide, and has an integral Backsplash and Sprayhead. Bowl is finished with a clear polyurethane coating. Standard color is Palomino Tan. See available color selection.

#### Barrier-Free Conformance

Units conform with ANSI, UFAS, ADA and OBC requirements for accessibility. Compliance is subject to the interpretation and requirements of the local code authority.

**Hand Pushbutton** (suffix option -H) operates an individual non-hold open, Air-Controlled Metering Valve and can be field set for flow ranging from 5 to 60 seconds. Pushbutton requires less than 5 pounds of force to activate valve.

**Electronic Sensor Operation** (suffix option -SO) includes individual Solenoid Valves activated by Infrared Sensors. A plug-in style Transformer is provided.

**Foot Pushbutton** is not available on this model.

**Spray Nozzle** is vandal-resistant and provides a concentrated 0.5 GPM spray.

**Hot & Cold Supplies** are blended in an ASSE 1070 compliant temperature/pressure balancing Mixing Valve with Integral Checks and Strainers. A minimum of 30 PSI supply pressure is required.

**Shroud** is heavy gage, stainless steel.

#### GUIDE SPECIFICATION

Provide and install Acorn Terrazzo Uni-Lav (specify model number and options). Bowl shall be reinforced cast Terrazzo polished and sealed with a clear polyurethane coating, and shall have an integral Backsplash and Sprayhead. Spray Nozzle shall be vandal-resistant type with 0.5 GPM flow control. Provide an ASSE 1070 compliant temperature/pressure balancing Mixing Valve with Integral Checks and Strainers in hot and cold supply and field set water temperature at 105 degrees Fahrenheit. Shroud shall be heavy gage, stainless steel. Terrazzo Uni-Lav shall be mounted using Carrier Arms, supplied by others. Units to conform with ANSI, UFAS, and ADA requirements for accessibility.



# Wash-Ware®: 3601 Acorn Terrazzo Uni-Lav - 1 Station - ADA Compliant

## MODEL NUMBER AND OPTIONS SELECTION

### BASE MODEL NUMBER (Must Specify)

-3601 Off-Floor, 1 Station Uni-Lav

### FIXTURE MOUNTING AND WASTE (Must Specify)

-1 Off-Floor, Wall Outlet

### OPERATION (Must Specify)

- H Hand Operation
- PPZ Programmable Piezo Pushbutton Electronic Metering
- SO Sensor Operation
- SO-BAT Sensor Operation (Batteries Not Included)

### TERRAZZO® OPTIONS (Must Specify)

Color: \_\_\_\_\_  
(Refer to <https://www.acorneng.com/terrazzo-colors>)

### PRODUCT OPTIONS

-ST Single Temperature Supply

### RIM HEIGHT OTHER THAN STANDARD

Note: 34" Max Rim Height - Complies to ADA, OBC and CBC

-JH31 31" ADA/CBC Children's Rim Height

### SUPPLY AND VENT

Not applicable to this model

### -PDM METERING LIQUID SOAP DISPENSER

Not applicable on this model

Please visit [www.acorneng.com](http://www.acorneng.com) for most current specifications.

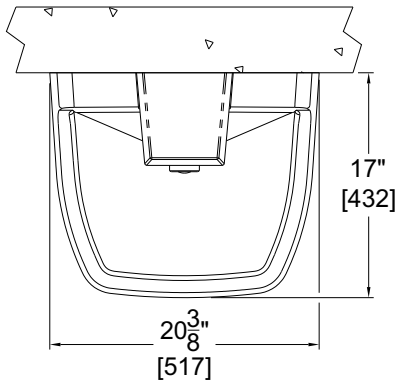

1. -H Hand Operated Pushbutton
2. Spray Nozzle
3. P-Trap Cover
4. SO- Sensor Operation

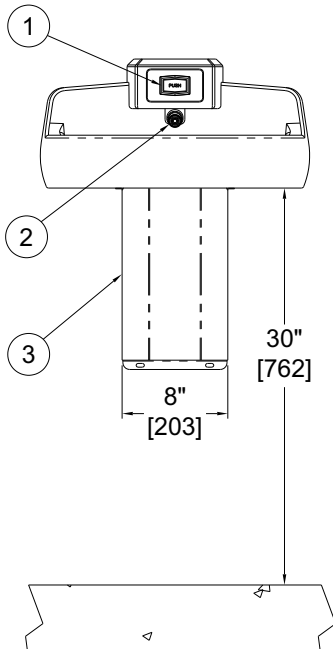

MODEL# 3601-1-H

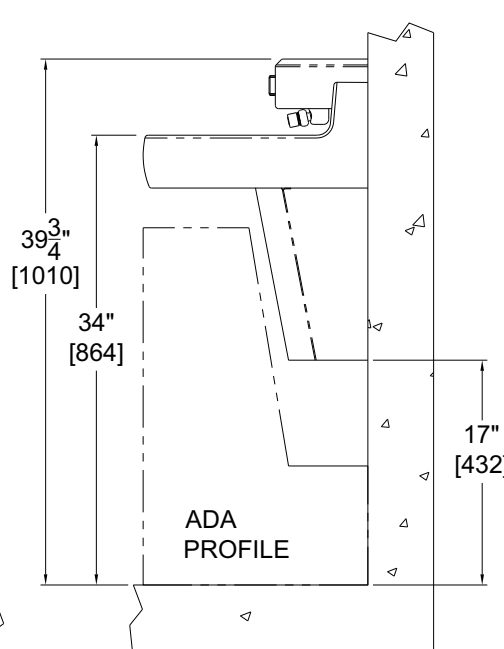

ADA PROFILE

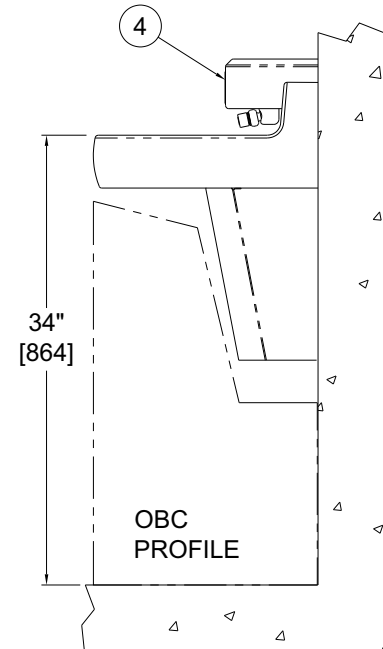

OBC PROFILE

MODEL# 3601-1-SO

**WARNING:** Cancer and Reproductive Harm - [www.P65Warnings.ca.gov](http://www.P65Warnings.ca.gov)

<p><b>Important:</b> Installation instructions and current rough-in are furnished with each fixture. Do not rough in without certified dimensions. Dimensions are subject to manufacturer's tolerance of plus or minus 1/4" and change without notice. Acorn assumes no responsibility for use of void or superseded data. © Copyright 2006 Acorn Engineering Company</p>	
<p>Selection Summary</p> <p>Model No. &amp; Option _____</p> <p>Quantity _____</p>	<p>Approved for Manufacturing</p> <p>Company _____ Title _____</p> <p>Signature _____ Date _____</p>