



## Shower-Ware® 470BHC Series

Three Station Shower w/ Handicap Station - Non ADA Compliant



478BHCR-W-RD

Fixture May Show Some Available Options

- Patented D697,591
- © Acorn Engineering Co.

**CONTROLS**  
INSIDE

Please visit [www.acorneng.com](http://www.acorneng.com) for most current specifications.

### Three Station Shower w/HC Station - Non ADA Compliant

**-HC Handicap Shower** station includes a diverter valve with a Patented Ligature Resistant ADA Compliant Tri-Lever Handle (Standard with T/P valve only) or a lever handle , a handheld shower with on/off pushbutton, vacuum breaker, upper showerhead, a recessed soap dish and a 24" x 1-1/2" stainless steel grab bar. Unit does not fully conform with ADA requirements.

**Housing** is 18 gage, type 304 stainless steel with satin finish.

**Supply Piping** is flex hose and bronze or wrought copper fittings. Showerhead riser and valve supply inlet piping may differ. Supply stub-out is sized to provide adequate water to each head simultaneously. Piping is hydrostatically tested at 150 PSI.

**Control Valve** type is indicated by selected Apex model number. All valves have replaceable cartridges which contain all wearing parts and are serviced from the face of the shower for easy maintenance. Valve is tamper-resistant and may include an easy to close mechanism and low leverage handle to protect the operating parts from excessive torque.

**Showerheads.** A handheld shower with on/off button, 60" hose, quick-disconnect and 1.5 GPM flow control is provided. A conventional fixed showerhead is also provided at 6'-0" discharge height. Showerhead is solid brass, triple chrome-plated and include built-in 1.6 GPM flow restrictor. The Acorn Logan Wizard Showerhead design provides self-cleaning with every use, and has an adjustable spray pattern from a coarse stream to a fine mist.

**Fasteners.** Acorn furnishes all exposed tamper-resistant fasteners necessary to complete the on-site shower assembly; however, concealed wall fasteners or anchor shields are not furnished.

**Privacy Compartments.** Disabled bathers understandably should be given privacy while bathing. This suggests providing a separate cubicle not in the group shower room.

#### GUIDE SPECIFICATION

Provide and install Acorn Apex Three Station Shower w/ HC Station (specify model numbers and options). Housing shall be 18 gage, type 304 stainless steel with satin finish. Shower shall be factory pre-piped and hydrostatically factory tested to 150 PSI. Fixture shall be furnished with a control valve, a handheld shower with on/off pushbutton, vacuum breaker, upper showerhead, a diverter valve with a Patented Ligature Resistant Tri-Lever Handle or a lever handle , a recessed soap dish (handicapped station) and a 24" x 1-1/2" stainless steel grab bar. Unit does not fully conform with ADA requirements. Installation shall be made in accordance with manufacturer's recommendations and details.

# Shower-Ware®: 470BHC Three Station Shower w/ HC Station - Non ADA Compliant



## Showerhead Discharge Height (Not Part of Model Number)

6'-0"  5'-6"  5'-0"  Other (Specify) \_\_\_\_\_

## MODEL NUMBER AND OPTIONS SELECTION

### SERIES (Must Specify)

-4 Apex

### TYPE (Must Specify)

-7 Three Station Handicap Shower

### VALVE (Must Specify)

- 0 Electronic Valves, Single-Temp Metering
- 6 Air-Control, Single Temperature Metering
- 8 T/P Temperature-Pressure Balancing Mixing Valve With Patented Ligature Resistant ADA Tri-Lever Handle (ASSE 1016 Compliant)

### ELECTRONIC VALVE SELECTION

#### Master-Trol® (Electronic)

- EVS1 Single Temp
- EVSP1 Single Temp, Piezo Button

#### Master-Trol® PLUS (Electronic)

- MTP1 Single Temp
- MTPP1 Single Temp, Piezo Button

#### Time-Trol® (Electronic)

- MVC1 Single Temp

#### Programmable (Electronic) w/9VDC Plug-In Transformer

- PPZ1 Single Temp Programmable Piezo Button

### SUPPLY (Must Specify)

- T Top
- W Wall

### HC ORIENTATION (Must Specify)

Handicap Station includes Recessed Soap Dish

- L L.H. Side
- R R.H. Side

### VALVE OPTIONS

- CI Cycle Interrupt for Time-Trol Valves
- LVR Lever Handle (-8 & -Diverter Valves)
- PBH Hemispherical Pushbutton
- TF Transformer, 120VAC to 24VAC (-MVC option only)

### SHOWERHEAD OPTIONS

- CSH Conical Showerhead (Ligature Resistant)
- CSH-WSA WaterSense Approved 1.5 GPM Conical Showerhead (Ligature Resistant)
- F Flow Control
  - 2.0 GPM (Not Available For Use in California)
- FH Fixed Head in Lieu of Handheld Shower
- HL Hi-Lo Mounting Brackets (For Handheld Shower)
- MSH Multi-Stream Showerhead
- P Penal Showerhead
- PSO Positive Shut-Off for Quick-Disconnect
- Y Universal Ball Joint
- YY Lockable Universal Ball Joint

### PRODUCT OPTIONS

- BS Built-in Liquid Soap System
- D Soap Dish
- DS Diana Circular Privacy (See Diana Privacy Submittals)
- EG Enviro-Glaze Color, Specify \_\_\_\_\_
- FG 14 Gage Material Construction
- LGB Less Grab Bar
- LRD Less Recessed Soap Dish (HC Station)
- RD Recessed Soap Dish (Non-Handicap Station)
- SC Supply Cover, Ceiling Height \_\_\_\_\_
- SLPB Sloping Bottom
- SLPT Sloping Top
- WH Wide Housing

Please visit [www.acorneng.com](http://www.acorneng.com) for most current specifications.

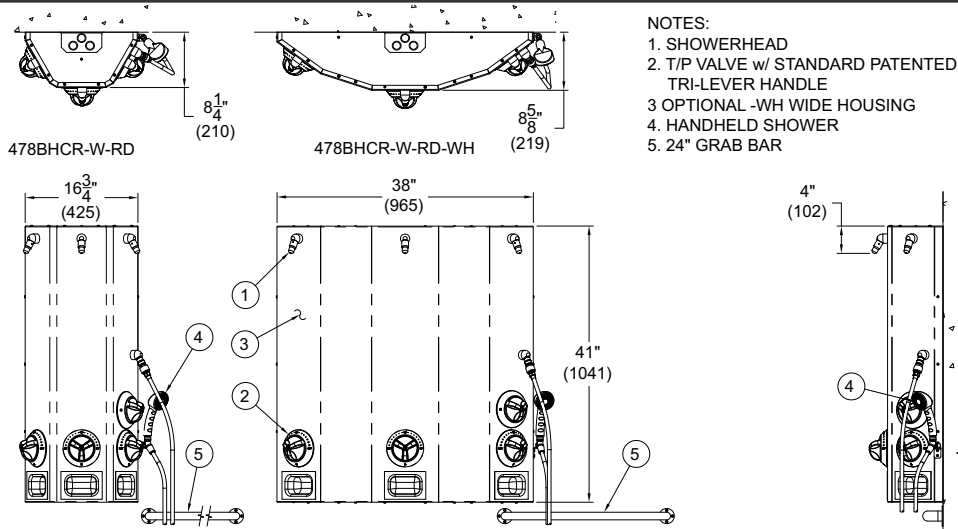

- NOTES:
1. SHOWERHEAD
  2. T/P VALVE w/ STANDARD PATENTED TRI-LEVER HANDLE
  3. OPTIONAL -WH WIDE HOUSING
  4. HANDHELD SHOWER
  5. 24" GRAB BAR

**WARNING:** Cancer and Reproductive Harm - [www.P65Warnings.ca.gov](http://www.P65Warnings.ca.gov)

<p><b>Important:</b> Installation instructions and current rough-in are furnished with each fixture. Do not rough in without certified dimensions. Dimensions are subject to manufacturer's tolerance of plus or minus 1/4" and change without notice. Acorn assumes no responsibility for use of void or superseded data. © Copyright 2006 Acorn Engineering Company</p>	
<p style="text-align: center;">Selection Summary</p> <p>Model No. &amp; Option _____</p> <p>Quantity _____</p>	<p style="text-align: center;">Approved for Manufacturing</p> <p>Company _____ Title _____</p> <p>Signature _____ Date _____</p>