



ACORN SAFETY
P.O. BOX 3527
CITY OF INDUSTRY, CA 91744-0527
UNITED STATES OF AMERICA
WWW.ACORNSAFETY.COM

INSTALLATION, OPERATION AND MAINTENANCE INSTRUCTIONS

EYE/FACE WASH ELECTRIC ALARM WITH FLASHING LIGHT AND HORN



Models S0000-AL4 and S000-AL4-ASW

TECHNICAL ASSISTANCE TOLL FREE TELEPHONE NUMBER

1.800.591.9360

TECHNICAL ASSISTANCE FAX: 1.626.855.4894

NOTES TO THE INSTALLER:

- 1. Please leave this documentation with the owner of the fixture when finished.**
- 2. Please read this entire booklet before beginning the installation.**
- 3. Check your installation for compliance with plumbing, electrical, ANSI Z358.1 and other applicable codes.**

LIMITED WARRANTY

UNITED STATES AND CANADA

Acorn Safety warrants that its products are free from defects in material or workmanship under normal use and service for a period of one year from date of shipment. Acorn's liability under this warranty shall be discharged solely by replacement or repair of defective material, provided Acorn is notified in writing within one year from date of shipment, F.O.B. Industry, California.

This warranty does not cover installation or labor charges and does not apply to materials, which have been damaged by other causes such as mishandling or improper care or abnormal use. The repair or replacement of the defective materials shall constitute the sole remedy of the Buyer and the sole remedy of Acorn under this warranty. Acorn shall not be liable under any circumstances for incidental, consequential or direct charges caused by defects in materials, or any delay in the repair or replacement thereof. This warranty is in lieu of all other warranties expressed or implied. Product maintenance instructions are issued with each unit and disregard or non-compliance with these instructions will constitute an abnormal use condition and void the warranty. Stainless steel must be protected on job sites during construction and must be properly maintained after the water has been introduced into the safety product or Acorn's warranty is void.

PRELIMINARY STEPS

1. Read the installation instructions prior to beginning the installation.
2. Separate parts from packaging and verify all necessary parts are accounted for and undamaged. Obtain missing or damaged parts from Acorn Safety prior to beginning installation.
3. Flush water supply lines prior to installation. This will remove unwanted debris from the lines and prevent unwanted blockages in the safety equipment.
4. In order to comply with ANSI Z358.1, the safety equipment must be inspected periodically. An inspection tag is provided for documentation purposes.
5. All employees at risk of contamination should be informed and trained in the use of this and any other safety equipment. The signage provided should be posted appropriately in close proximity to this equipment.

**ROUGH-IN
S0000-AL4**

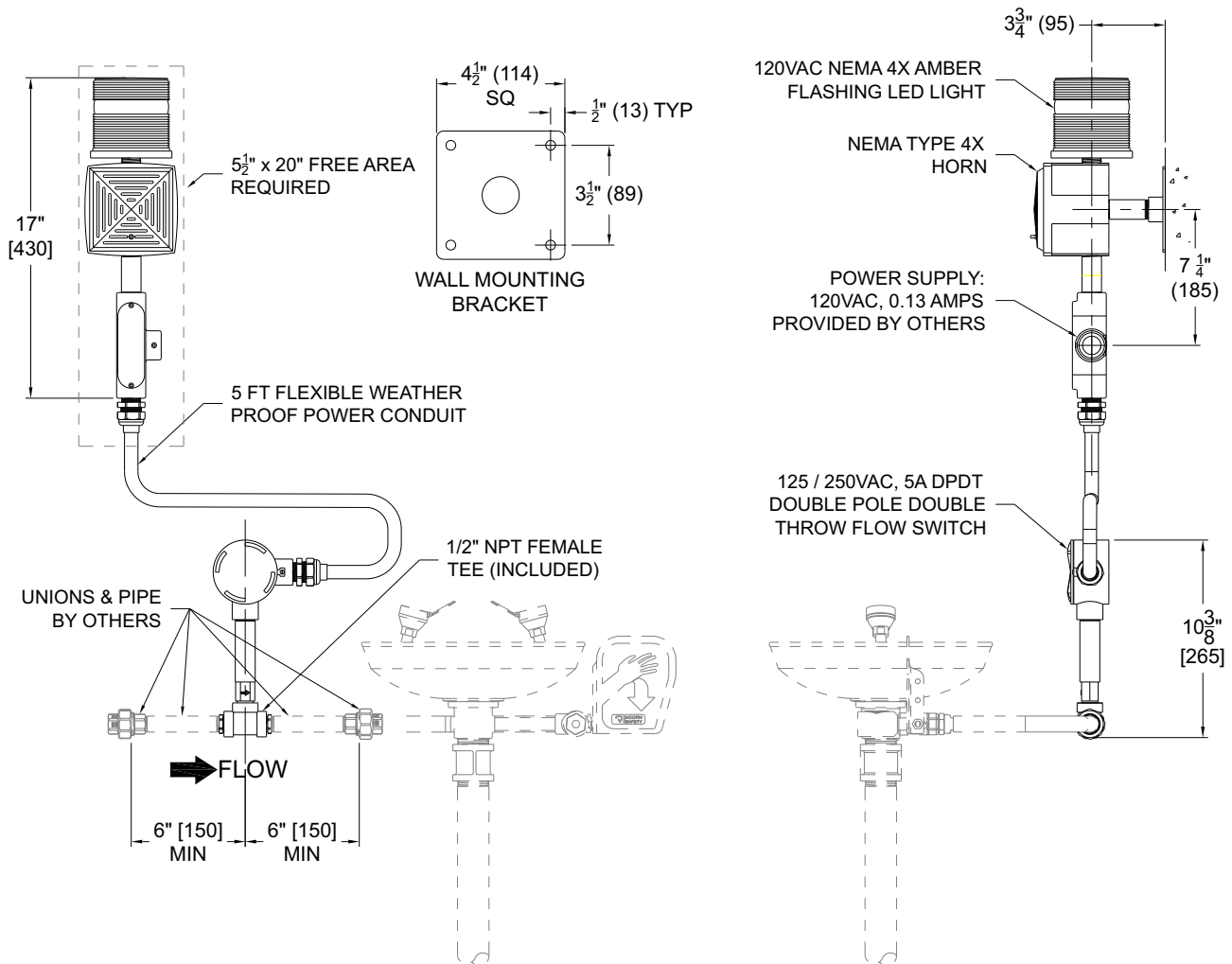

GENERAL NOTES:

1. ALL DIMENSIONS ARE IN INCHES [MM].
2. FLOW SWITCH SHALL BE INSTALLED VERTICALLY WITH HORIZONTAL FLOW.
3. DIRECTION OF WATER FLOW MUST BE IN SAME DIRECTION AS SHOWN ON FLOW SWITCH.
4. HORN INCLUDES AN EXTERNAL ADJUSTMENT SCREW AND MAY BE ADJUSTED FROM 73 dB TO 103 dB AT 10 FEET.

ROUGH-IN
S0000-AL4-ASW

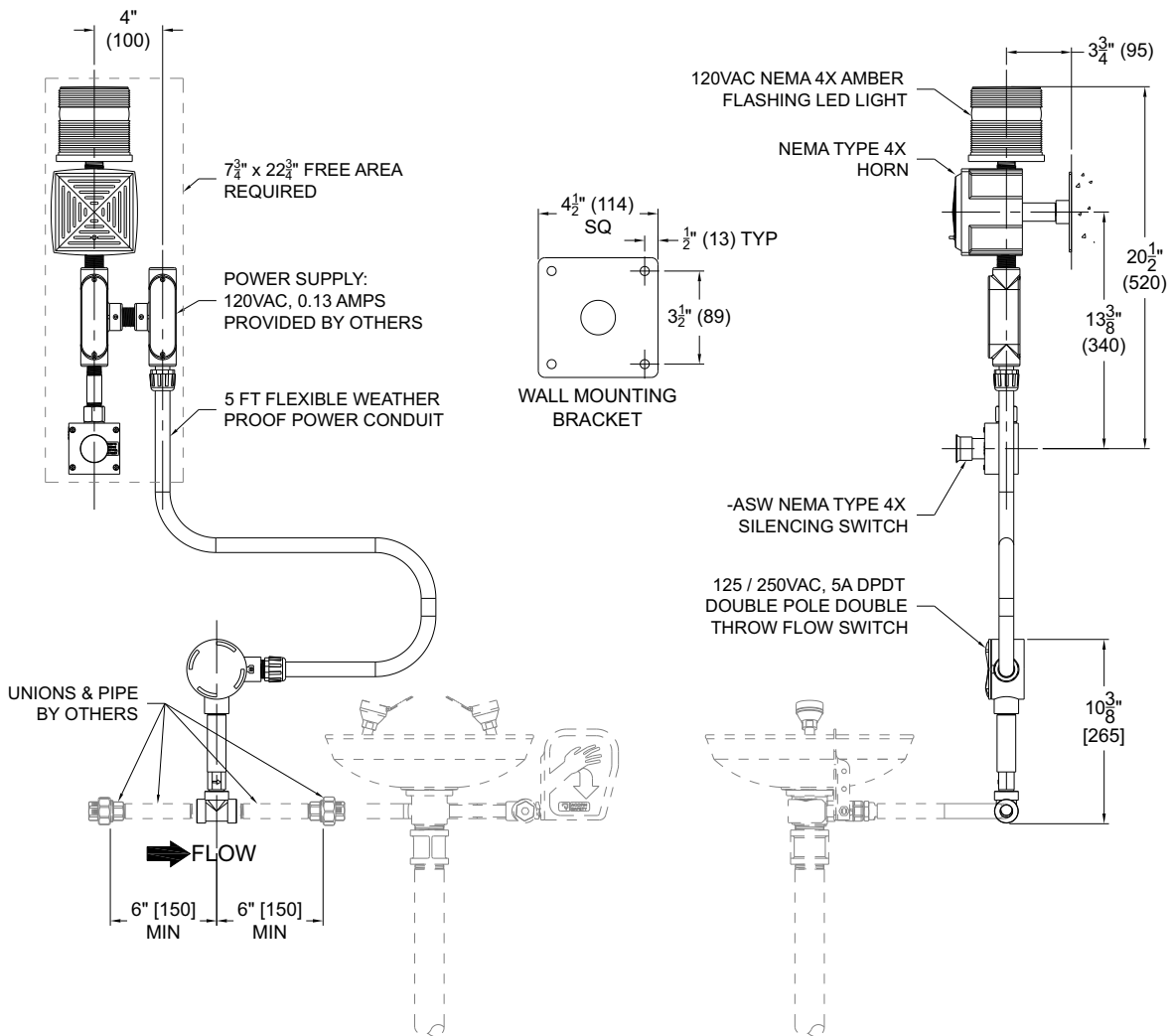

- GENERAL NOTES:
1. ALL DIMENSIONS ARE IN INCHES [MM].
 2. FLOW SWITCH SHALL BE INSTALLED VERTICALLY WITH HORIZONTAL FLOW.
 3. DIRECTION OF WATER FLOW MUST BE IN SAME DIRECTION AS SHOWN ON FLOW SWITCH.
 4. HORN INCLUDES AN EXTERNAL ADJUSTMENT SCREW AND MAY BE ADJUSTED FROM 73 dB TO 103 dB AT 10 FEET.

ELECTRICAL WIRING
S0000-AL4

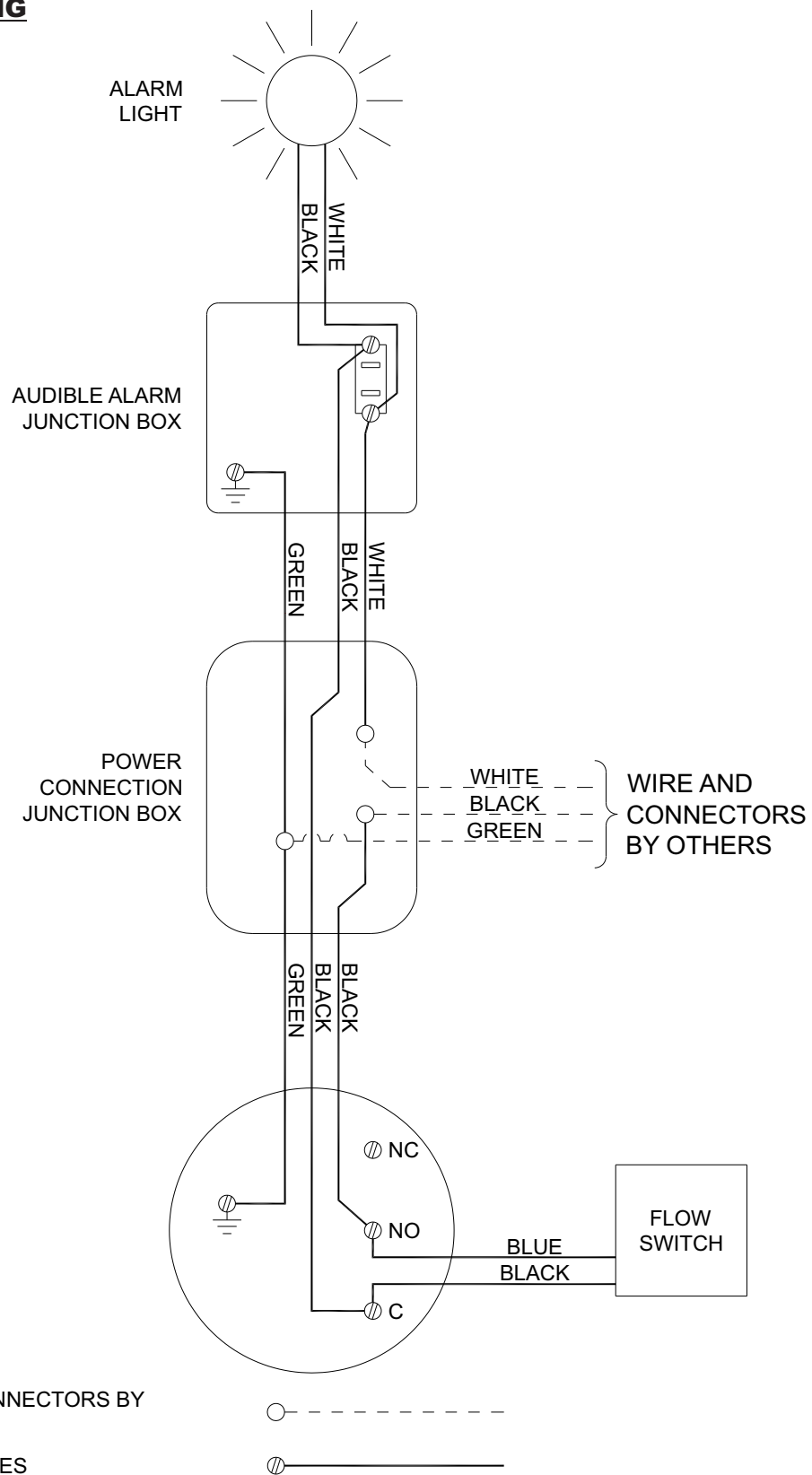

NOTES:
WIRE AND CONNECTORS BY OTHERS
EXISTING WIRES

ELECTRICAL WIRING
S0000-AL4-ASW

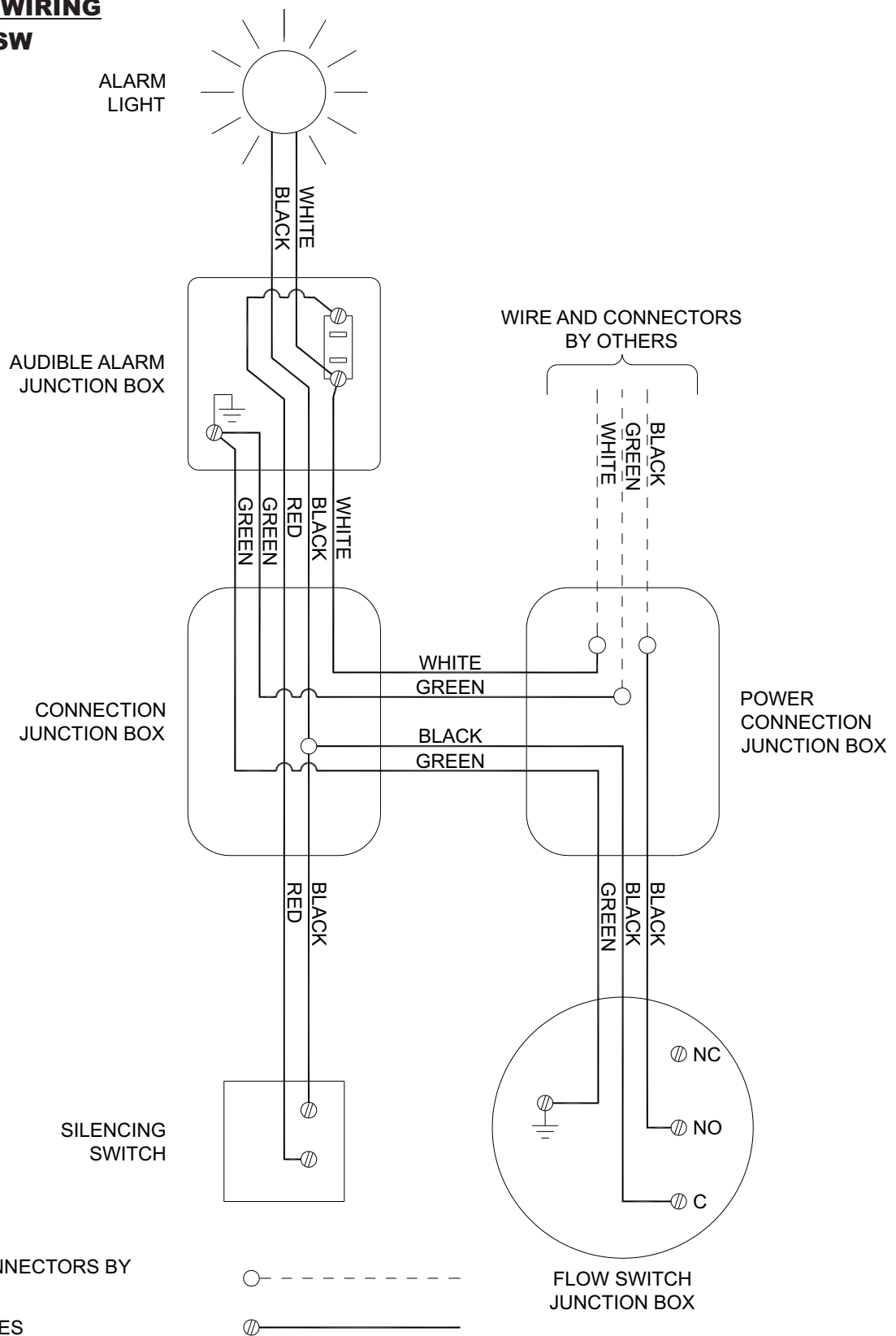

INSTALLATION INSTRUCTION

Supplies required: (not provided by Acorn)

1. 14 gauge UL building wire to make up connections from (flow switch & light/alarm) to electrical service.
2. Piping (½" NPT), unions or other connections to meet required minimum distances for flow switch.
3. Wall anchoring hardware and fasteners for bracket & signage mounting.
4. Pipe sealant or Teflon tape for sealing water connections.

IMPORTANT: FLUSH WATER SUPPLY LINES PRIOR TO CONNECTION TO SAFETY EQUIPMENT.

Notes:

- Flow Switch must be installed with tee fitting in horizontal position, flow switch body in vertical position and at least 6" from closest fitting.
- Flow Switch direction of flow is indicated on switch body.
- Use hand tools and wrenches in a manner which will prevent marring finished surfaces. Strap wrenches or tools with plastic jaw linings are highly recommended.
- Refer to fixture rough-in information for location of supply.
- Fragments of Teflon tape or pipe sealant residue can interfere with the proper operation of this unit. Ensure pipe sealing methods do not cause contamination in the system.

STEP ONE:

FLOW SWITCH INSTALLATION

1. Determine location of flow switch in water supply line. The inlet and outlet ports of the flow switch must be a minimum of 6" from any tees or elbows in the water supply line. Refer to fixture installation and rough-in drawing.
2. Mount the flow switch in-line of fixture supply inlet. The switch body must be in the vertical position with the water pipe horizontal. The water flow must be in the direction of the arrow that is marked on the flow switch body.

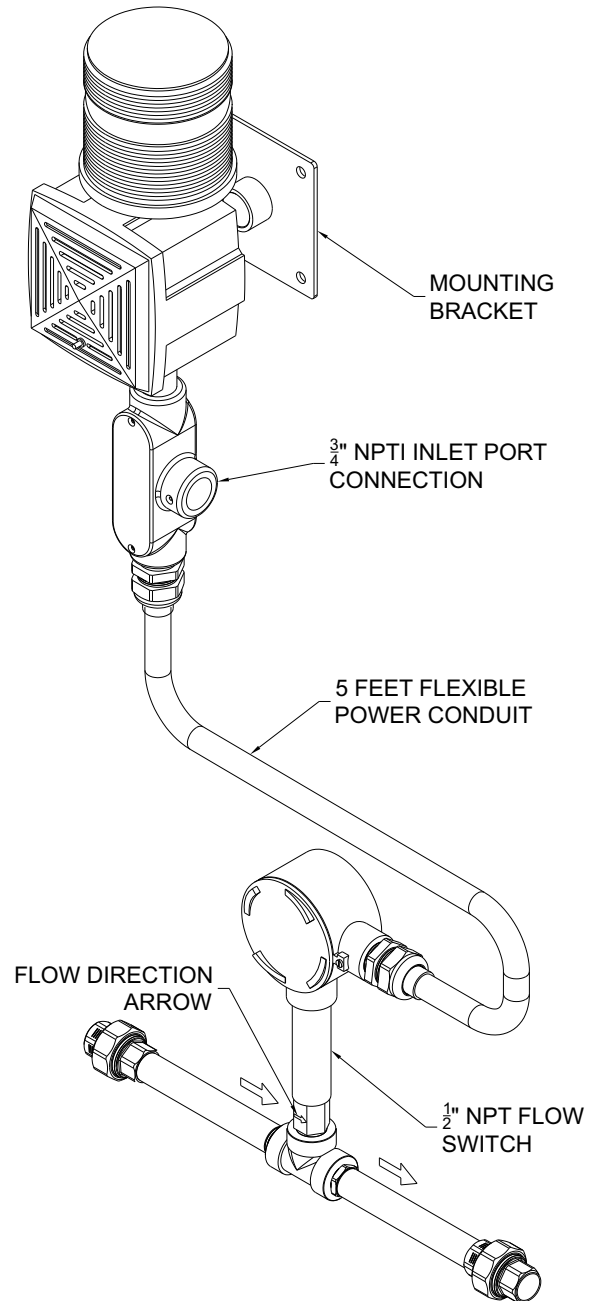

STEP TWO: ELECTRICAL CONNECTIONS

1. Determine location for mounting alarm and light. Light should be positioned a minimum of 7 feet above the ground for best visibility.
2. Use wall mounting bracket provided as a template to locate wall anchors and fix bracket with installer provided hardware.
3. Install flexible power cable to alarm and flow switch. Flexible conduit may be trimmed for desired length.
4. Connect unit to power leads in the conduit body as labeled. Connect the three leads inside.

NOTE: DO NOT SEPARATE WIRES ALREADY CONNECTED

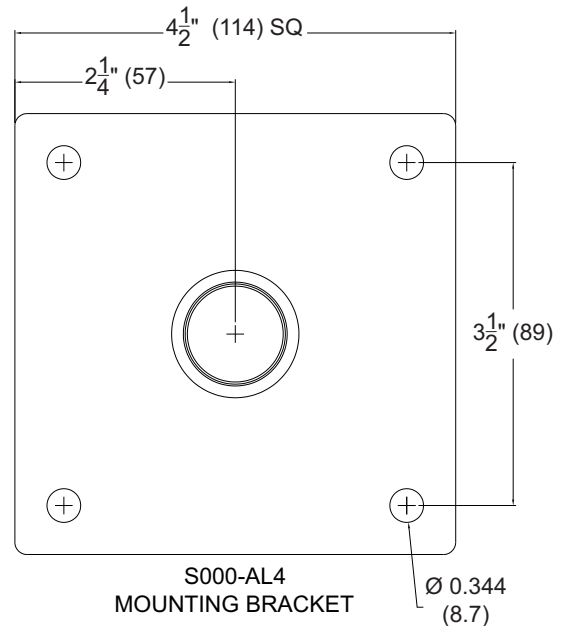

STEP THREE: TEST

1. Apply power to alarm and light. Unit should not be operating if safety equipment is not activated.
2. Supply water to fixture and flush air from system.
3. Activate safety equipment. Alarm and Light should now be operating.
4. De-activate safety equipment. Alarm and light should now automatically de-activate.

ASW SILENCING SWITCH ONLY

5. Test silencing switch. Push silencing button, while alarm is active; the sound should stop and the light should continue to flash.
6. To reset -ASW Silencing Switch: Pull button firmly, an audible “pop” should be heard and a yellow band should be visible near the end of the mushroom button. NOTE: If the yellow band is not visible, switch is not reset and the horn will not sound next time alarm is activated.

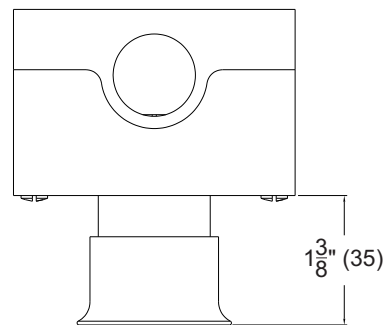

TO RESET AFTER SILENCING ALARM, ASW PUSHBUTTON MUST BE PULLED FIRMLY TO THE FULLY EXTENDED POSITION.

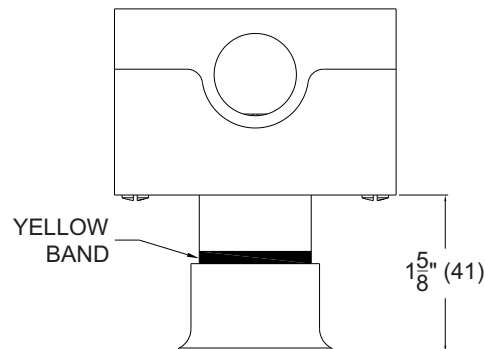

WHEN FULLY EXTENDED, A VISIBLE YELLOW BAND WILL BE APPEAR ON THE PUSHBUTTON SHAFT.

PARTS LIST

S0000-AL4

ITEM #	PART NUMBER	DESCRIPTION
1	7103-202-199	AMBER FLASHING LED LIGHT
2	7103-208-000	CONDUIT NIPPLE 1/2" NPT X 1-1/8" LG
3	7103-206-000	3/4"-1/2" NPT REDUCING COUPLING
4	7103-207-199	AUDIBLE ALARM WITH ADDITIONAL 3/4" NPT
5	7103-203-000	CONDUIT BODY 3/4" NPT
6	7103-209-199	CONDUIT NIPPLE 3/4" NPT X 3" LG
7	7103-219-001	JUNCTION BOX MOUNTING BASE
8	7103-206-000	3/4" x 1/2" NPT REDUCING BUSHING
9	7103-223-000	1/2" WATERTIGHT FLEXIBLE CONDUIT, 5 FT
10	7103-102-001	FLOW SWITCH ASSY, 3/8" - 1/2" NPT, DPDT

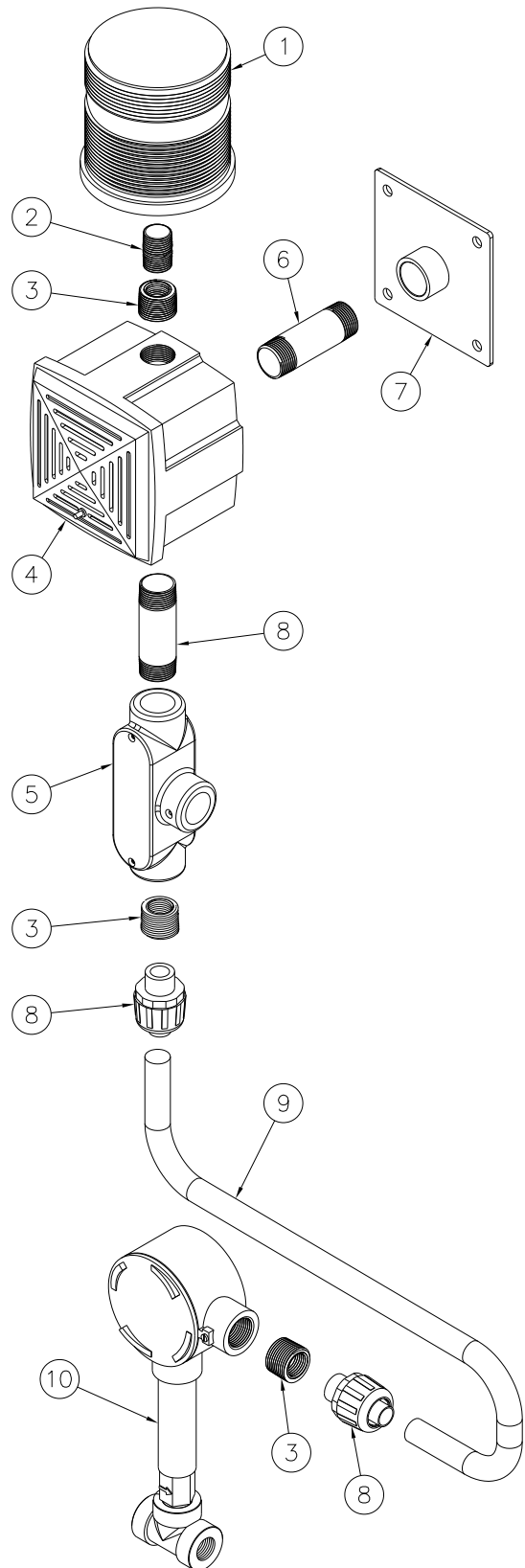

PARTS LIST

S0000-AL4-ASW

ITEM #	PART NUMBER	DESCRIPTION
1	7103-202-199	AMBER FLASHING LED LIGHT
2	7103-208-000	CONDUIT NIPPLE 1/2" NPT X 1-1/8" LG
3	7103-206-000	3/4"-1/2" NPT REDUCING COUPLING
4	7103-207-199	AUDIBLE ALARM WITH ADDITIONAL 3/4" NPT
5	7103-203-000	CONDUIT BODY 3/4" NPT
6	7103-209-199	CONDUIT NIPPLE 3/4" NPT X 3" LG
7	7103-219-001	JUNCTION BOX MOUNTING BASE
8	7103-206-000	3/4" x 1/2" NPT REDUCING BUSHING
9	7103-223-000	1/2" WATERTIGHT FLEXIBLE CONDUIT, 5 FT
10	7103-102-001	FLOW SWITCH ASSY, 3/8" - 1/2" NPT, DPDT
11	7103-228-00	1/2" x 3" LONG NIPPLE CONDUIT FITTING
12	7103-229-000	1/2" ADAPTER ELECTRICAL FITTING
13	7103-231-000	NYLON WASHER
14	0308-001-000	1/2" NPS PLATED STEEL LOCKNUT
15	7103-221-199	ASW AUDIBLE ALARM SILENCING SWITCH

