

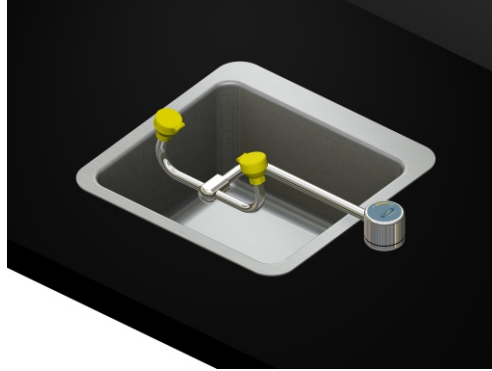

ACORN SAFETY
P.O. BOX 3527
CITY OF INDUSTRY, CA 91744-0527
UNITED STATES OF AMERICA
www.acorneng.com

INSTALLATION, OPERATION AND MAINTENANCE INSTRUCTIONS

EYE/FACEWASH



**Models S0950-LH / S0950-RH / S0960-LH / S0960-RH/
S0950-LH-AS / S0950-AS / S0960-LH-AS / S0960-RH-AS**

TECHNICAL ASSISTANCE TOLL FREE TELEPHONE NUMBER

1.800.591.9360

TECHNICAL ASSISTANCE FAX: 1.626.855.4894

NOTES TO THE INSTALLER:

- 1. Please leave this documentation with the owner of the fixture when finished.**
- 2. Please read this entire booklet before beginning the installation.**
- 3. Check your installation for compliance with plumbing, electrical, ANSI Z358.1 and other applicable codes.**

LIMITED WARRANTY

UNITED STATES AND CANADA

Acorn Safety warrants that its products are free from defects in material or workmanship under normal use and service for a period of one year from date of shipment or 18 months after the date of shipment from factory, whichever comes first. Acorn's liability under this warranty shall be discharged solely by replacement or repair of defective material, provided Acorn is notified in writing within one year from date of shipment, F.O.B. Industry, California.

This warranty does not cover installation or labor charges and does not apply to materials, which have been damaged by other causes such as mishandling or improper care or abnormal use. The repair or replacement of the defective materials shall constitute the sole remedy of the Buyer and the sole remedy of Acorn under this warranty. Acorn shall not be liable under any circumstances for incidental, consequential or direct charges caused by defects in materials, or any delay in the repair or replacement thereof. This warranty is in lieu of all other warranties expressed or implied. Product maintenance instructions are issued with each unit and disregard or non-compliance with these instructions will constitute an abnormal use condition and void the warranty. Stainless steel must be protected on job sites during construction and must be properly maintained after the water has been introduced into the safety product or Acorn's warranty is void.

PRELIMINARY STEPS

1. Read the installation instructions prior to beginning the installation.
2. Separate parts from packaging and verify all necessary parts are accounted for and undamaged. Obtain missing or damaged parts from Acorn Safety prior to beginning installation.
3. Flush water supply lines prior to installation. This will remove unwanted debris from the lines and prevent unwanted blockages in the safety equipment.
4. In order to comply with ANSI Z358.1, the safety equipment must be inspected periodically. An inspection tag is provided for documentation purposes.
5. all employees at risk of contamination should be informed and trained in the use of this and any other safety equipment. The signage provided should be posted appropriately in close proximity to this equipment.

ROUGH-IN

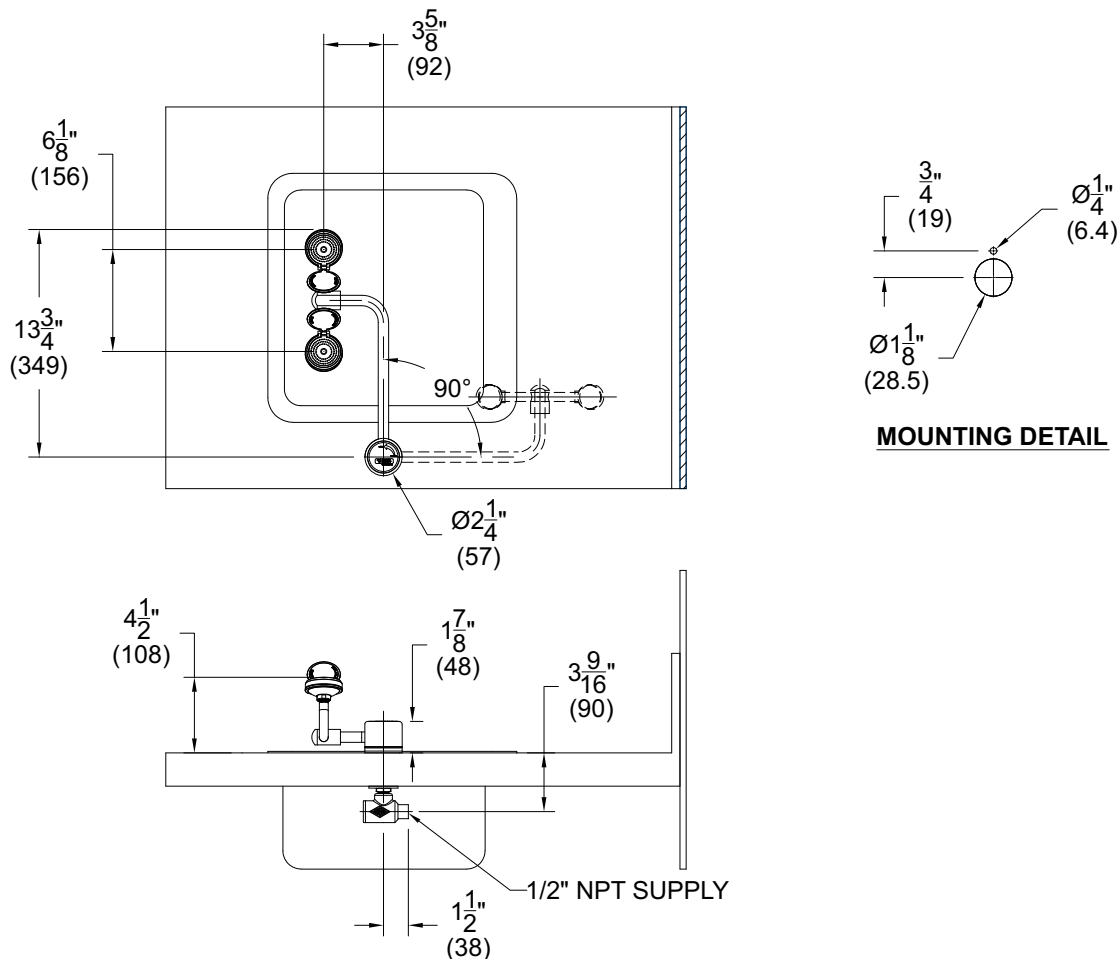

NOTE:

1. ALL DIMENSIONS ARE IN INCHES [MM].
2. ANSI Z358.1 REQUIRES NOZZLES TO BE BETWEEN 33" [385] AND 45" [1143] ABOVE FLOOR.
3. RIGHT HAND MODEL SHOWN. LEFT HAND MODELS AVAILABLE.

INSTALLATION INSTRUCTIONS:

Supplies required: (not provided by Acorn)

1. Wall fasteners for sign mounting.
2. Pipe sealant or Teflon tape for sealing water connections.

IMPORTANT: FLUSH WATER SUPPLY LINES PRIOR TO CONNECTION TO SAFETY EQUIPMENT.

NOTES:

- Top of spray nozzles must be between 33" - 45' from finished floor in order to meet ANSI Z358.1
- Refer to Rough-in for location of supply and drain lines.
- Fragments of Teflon tape or pipe sealant residue can interfere with the proper operation of this unit. Ensure pipe sealant methods do not cause contamination in the system.

STEP ONE: MOUNTING

1. Remove strainer, nut & washer.
2. Position assembly on deck allowing clearance for spray heads when unit is in closed position and meets ANSI Z358.1 in open position.
3. Make appropriate preparations for mounting unit by drilling (2) holes (1) for supply and (1) for alignment pin.
4. Re-position assembly and install using supplied nut & washer.
5. Reinstall strainer.

STEP TWO: SUPPLY LINE

1. Install water line (supplied by others) in a position to align with 1/2" strainer.
2. Open water supply.
3. Test for leaks, proper operation and flow.

STEP THREE: SIGNAGE & INSPECTION

1. Position sign with clear visibility, in close proximity to safety equipment and mark mounting hole locations.
2. Select appropriate 1/4" anchors, screws and washers (Supplied by others) to install signage.
3. Attach inspection tag supplied, with plastic zip tie.

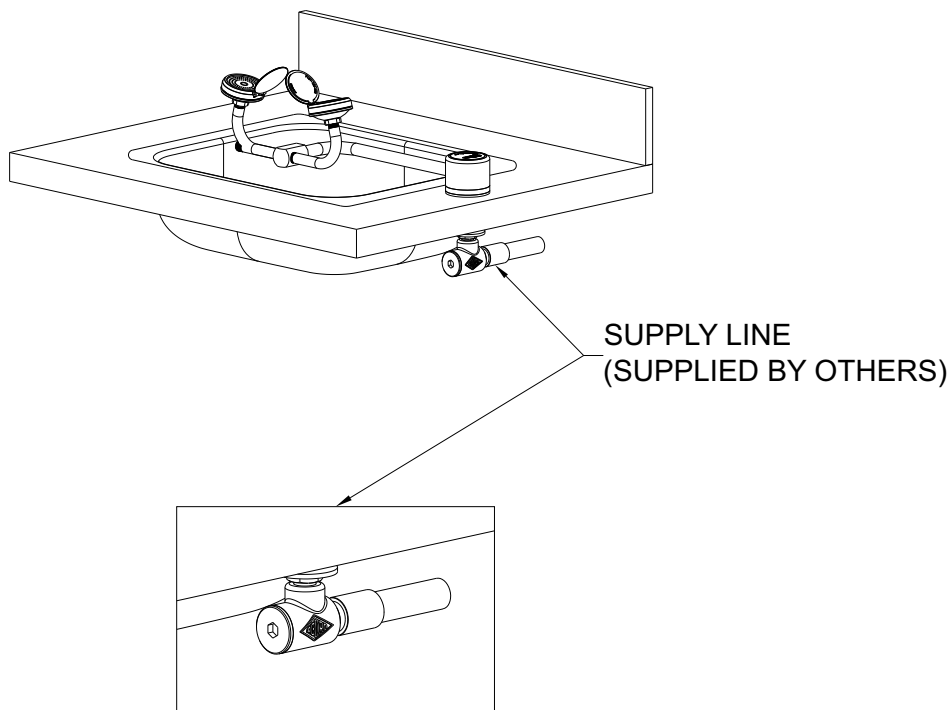

OPERATION INSTRUCTIONS:

Employees who work with hazardous materials should become familiar with the location and operation of the nearest emergency plumbing fixture. Emergency plumbing fixtures stations are simple to use and require hands free operation once the station is activated. Regular instruction regarding proper care and use will increase confidence that the units are accessible and function properly.

The route and area surrounding the Eye Wash should be clear and unobstructed; the sooner eyes are flushed, the less likelihood of damage. Eye Wash stations should be located in close proximity to the hazard and take no more than 10 seconds to reach. In the case of severe eye contamination the victim may require assistance to the Eye Wash station and help flushing their eyes.

Safety plumbing fixture equipment should be operated weekly for a period long enough to verify operation, clear the supply line of any sediment build-up and minimize microbial contamination due to sitting water.

1. To start the Eye Wash, swing spray nozzle assembly over the basin and push the paddle forward to the horizontal or fully "ON" position. Flushing should start, popping the spray nozzle caps open.
2. Lower both eyes into flow. Both eyes should be flushed to prevent contamination from one eye from being delivered to unaffected eye. Personnel who wear contact lenses should remove them immediately prior to or during the flush to prevent the contamination from remaining against the cornea possibly causing unnecessary damage or pain.
3. Using thumb and forefingers, fully open eyelids and flush eyes thoroughly for approximately 15 minutes or until medical personnel arrive. Be prepared to let the doctor know what type of contamination has entered the eye.
4. When finished return the push paddle to the vertical or fully "OFF" position and return spray nozzle assembly to standby position. Flushing fluid should stop. Once flushing fluid has stopped flowing, return spray nozzle lids to the closed position to protect from airborne contaminants.

MAINTENANCE GUIDE:

Maintain and inspect in accordance with ANSI Z358.1-2009

1. Check for obvious signs of wear, broken or defective equipment. Re-paint if necessary. Replace missing or defective equipment such as broken push paddles, missing signs and inspection tags.
2. Remove strainer and washout any debris collected –replace as required.
3. Operate Eye Wash nozzles by swinging the nozzle assembly over the basin to the fully "ON" position checking for smooth operation of valve push paddle mechanism at the same time ensuring that the Eye Wash spray nozzle caps pop off immediately when actuated. If the ball valve does not operate smoothly check the actuating assembly for binding or missing parts. If the

eye Wash spray nozzle caps do not pop off immediately when actuated check for correct supply inlet pressure.

4. While in operation, inspect spray nozzles for clogs or debris correct or replace as required.
5. Return push paddle to vertical or fully "OFF" position and swing back to stand by position. To prevent Eye Wash spray nozzles from becoming contaminated, always close nozzle lids after each use.

ITEM #	PART NUMBER	DESCRIPTION
1	7104-307-001	YOKE ASSY, LEFT-HAND
	7104-308-001	YOKE ASSY, RIGHT-HAND
2	7101-100-001	EYEWASH NOZZLE
	7101-104-001	FACEWASH NOZZLE
3	7100-406-000	LABEL, CW
	7100-407-000	LABEL, CCW
4	7104-045-150	LABEL DISC
	7104-043-000	RETAINING BOLT
5	7104-058-199	S/S RETAINING BOLT
	7104-048-001	SEAL RING KIT
7	7104-305-150	MOUNTING ADAPTER
8	7104-312-199	PIPE NIPPLE, 3/8 NPS WITH 3/8 NPT X 3"LG
	7104-343-199	S/S PIPE NIPPLE, 3/8 NPS WITH 3/8 NPT X 3"LG
9	0332-009-000	WASHER
	7104-342-001	S/S WASHER
10	0308-002-199	NUT
	7104-341-000	S/S NUT
11	7100-140-001	STRAINER
12	7104-047-001	VALVE, RIGHT HAND (INCLUDES ITEMS NO. 4, 5 & 6)
	7104-040-001	VALVE, LEFT HAND (INCLUDES ITEMS NO. 4, 5 & 6)
	7104-055-001	S/S VALVE, RIGHT HAND (INCLUDES ITEMS NO. 4, 5 & 6)

