



Est. 1954

ACORN ENGINEERING COMPANY

Manufacturers of Engineered Plumbing Products

HIGH SECURITY WITH LOW IMPACT

Integrated **Plumbing Solutions** and **Stainless Steel Products**
for Correctional Applications



OUR HISTORY



Acorn Engineering's correctional products are **manufactured in North America** by skilled craftsmen, with a history of quality since 1954.



Acorn Engineering's Family of Companies is a member of
US Green Building Council

MEMBERSHIPS AND ASSOCIATIONS

American Society of Plumbing Engineers (ASPE)
American Society of Mechanical Engineers (ASME)
American Society of Sanitary Engineers (ASSE)
IAPMO
Uniform Plumbing Code (UPC)
International Plumbing Code (IPC)
Plumbing and Drainage Institute
ASTM International and Standards
CSA Standards
American Rainwater Catchment Systems Association (ARCSA)
Rainwater Harvesting Standard
American Backflow Prevention Association (ABPA)
Construction Specifications Institute (CSI)
Mechanical Contractors Association of America (MCAA)
American Society for Healthcare Engineering

SINCE 1954...

THE LEADER IN CORRECTIONAL FIXTURES & SYSTEMS

Acorn Engineering has remained a trusted name in correctional facilities since the creation of the company's first plumbing fixtures in 1954. It's a name known for durability and vandal-resistance; for custom-engineered products that meet the specific demands of any institution.

Today, Acorn Engineering's family of companies includes 20 divisions manufacturing engineered plumbing fixtures and systems for schools, stadiums, hospitals, hotels, and many high-traffic or commercial environments. Acorn's product line is vast, but its expertise as the first manufacturer in the correctional market has remained.

Acorn Engineering serves as a single-source manufacturer to supply a project from start to finish. In this way, Acorn supports a "whole building" approach to security, with products that integrate to make specification and maintenance easy, reduce a facility's costs, and even save water and energy.



TABLE OF CONTENTS



- 04 Penal-Ware® Comby
- 06 Fixture Configurations
- 07 Stainless Steel Toilets
- 08 Suicide Resistant Products / Detox Toilets
- 09 Bariatric / International Toilets
- 10 Stainless Steel Lavatories / Basins
- 11 Stainless Steel Urinals
- 12 Correctional Accessories
- 14 Stainless Steel Wall Showers / Bases
- 16 Stainless Steel ADA Products 
- 17 Custom Engineering / Enviro-Glaze® Option
- 18 Drinking Fountains / Coolers / Drains
- 19 Case Study: Stainless Steel vs. Porcelain
- 20 Master-Trol® - Electronic Water Management System
- 21 Valve Options
- 22 AcornVac® Vacuum Plumbing
- 25 Case Study: Western Virginia Jail
- 26 Chronomite® Instantaneous Water Heaters
- 27 Water Savings Calculations



PENAL-WARE® COMBY



Penal-Ware® ADA Comby (1432-AR-2-BPH-04-M-GBC)



Penal-Ware® Comby (1415-AL-1-BPH-04-M-FV-PHRF-THR2-VAC)

OVER A MILLION COMBINATIONS OF COMBY

Acorn Engineering's Penal-Ware® accounts for every demand in a correctional facility with a vandal-resistant, sanitary, functional, and economical line of combys. Plumbing fixtures are manufactured in several configurations and modified with a wide variety of options. They are also highly-customizable.

For a facility looking to **retrofit for added security** or switch from porcelain to stainless steel, Acorn Engineering will provide a **product tailored to match existing rough-ins and reduce cost of installation.**

IAPMO Certified

ADA, UFAS and ANSI Compliant



Comby Features (please reference photo above)

- 1 14-gage, type 304 stainless steel
- 2 Seamless welding—no accessible voids or crevices where contraband can be concealed
- 3 1.6, 1.28 and 0.5 (vacuum) gpf models available
- 4 Pneumatic push button-operated valve
- 5 Off-floor (wall-mounted) models withstand up to 3,000 pounds of pressure; On-floor (floor-mounted) withstand up to 5,000 pounds without permanent damage
- 6 Concealed blowout jet with elongated bowl and self-draining flushing rim
- 7 Integral contoured seat
- 8 Cabinet interior sound-deadened with fire-resistant material

PENAL-WARE® COMBY



COMBY AS CONCEPT So many shapes, options, and accessories make for a perfectly customized design with every comby.

Above: (1418-CT-2-BPH-04-M-PHLF-FV-SPS)

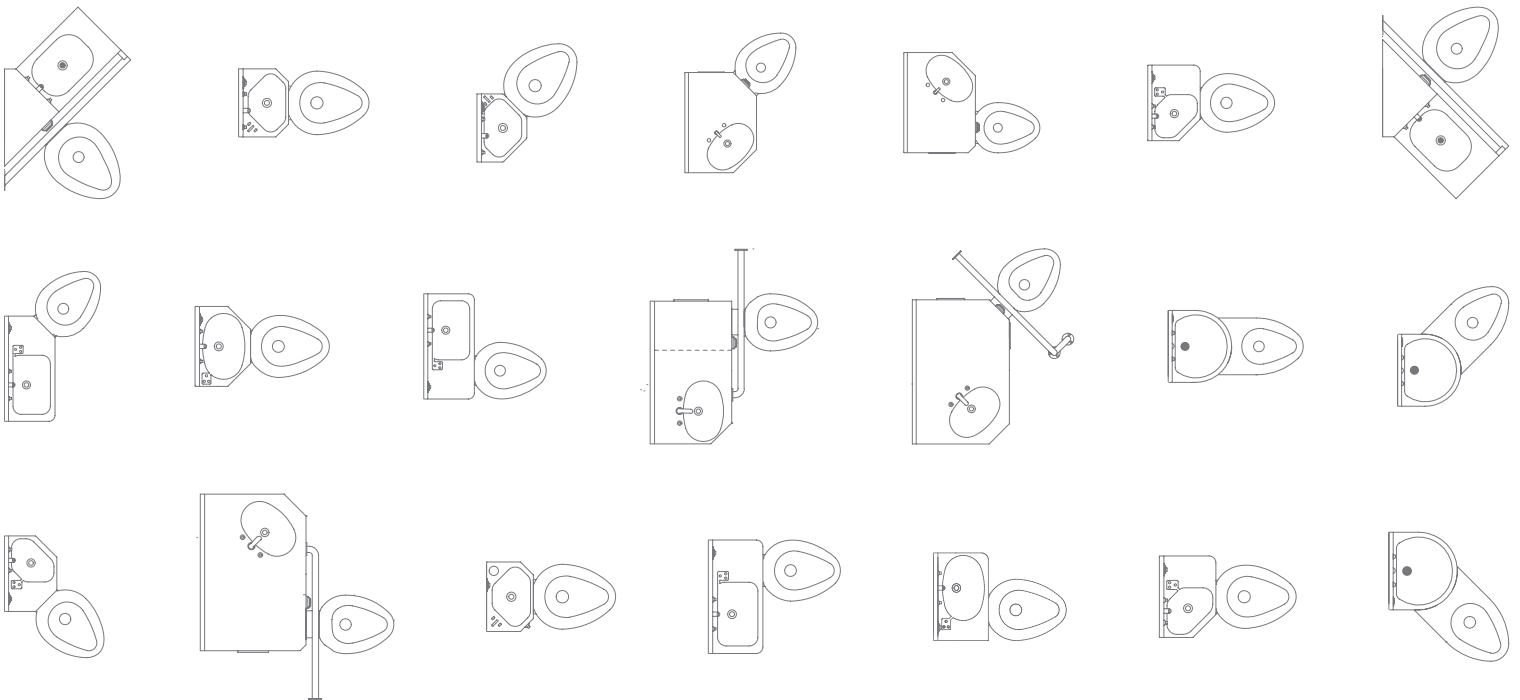

FIXTURE CONFIGURATIONS



On-floor, 18-inch Penal-Ware® Comby withstands 5,000 pounds of force without permanent deformation (1418-CT-2-BPH-04-M-FV-PHRF-SPS).

MODEL NUMBER	LAVATORY BOWL STYLE		
	Multi-Sided	Oval	Rectangle
1415 - 15" Comby	•		
1418 - 18" Comby	Optional	•	
1420 - 20" Comby		•	Optional
1426 - 26" Comby			•

 ANSI Compliant
 cUPC Certified

WASTE OUTLETS

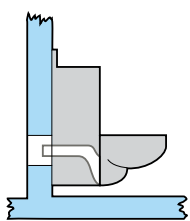

-1
Off-Floor,
Wall Outlet

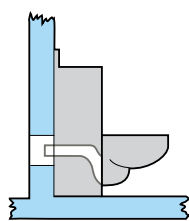

-2
On-Floor,
Wall Outlet

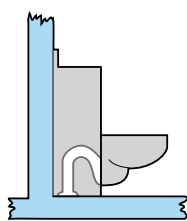

-3
On-Floor,
Floor Outlet

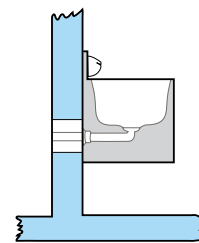

-1
Off-Floor,
Wall Outlet

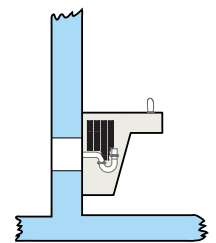

-1
Off-Floor,
Wall Outlet

Penal-Ware Combys and Toilets

Service Sinks, Lavatories, and Drinking Fountains

STAINLESS STEEL TOILETS



With on- or off-floor, rear mounted, and a variety of other options to choose from, there is a toilet option to fit every setting (some toilet bowl options shown).

PERFORMANCE LONGEVITY

Toilets are available in blowout or siphon jet, on- or off-floor design, with different waste outlet and mounting options from which to choose.

- 14-gage, type 304 stainless steel
- Seamless welding—no accessible voids or crevices where contraband can be concealed. Satin finish on exposed surfaces
- Off-floor (wall mounted) models withstand up to 3,000 lbs. of pressure; On-floor (floor mounted) withstand up to 5,000 pounds without permanent damage
- Concealed blowout or siphon jet with elongated bowl and self-draining flushing rim
- Integral contoured seat
- 1.6, 1.28 and 0.5 (vacuum) gpf models available
- Exposed top (-T) supply or concealed, wall (-W) supply flush valve model options available

FLOOD-TROL

This anti-flood system prevents toilet water overflow by sensing ahead pressure increase caused by rising water levels. Before a flood occurs, this sensor shuts off the water supply from the flush valve. A manual reset button, auto-reset, or electronic option reactivates the system only after the overflow line has been cleared.

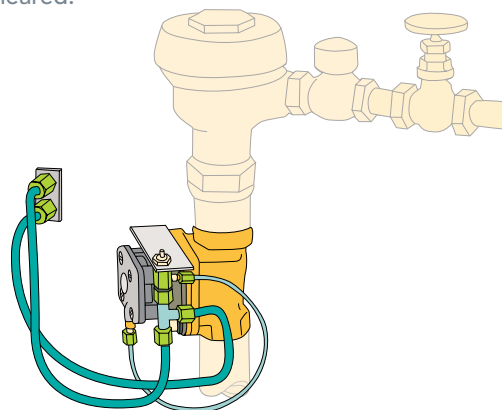

SUICIDE RESISTANT & DETOX TOILETS



Suicide Resistant Comby (1440-AR-2-BPH-03-M-LPFV)



Penal-Ware® Detox Toilet (1699-W-3)

SUICIDE RESISTANT PRODUCTS

- Suicide-resistant hemispherical and rounded design
- Suicide-resistant skirt
- Bariatric models (to accommodate weight requirements)
- Custom plumbing roughs
- Custom-manufactured modifications

DETOX TOILET

Detox toilets are useful in situations where a conventional toilet may present a hazard, such as in detoxification, safety, and isolation cells.

- Welded heavy-gage stainless steel construction
- Recessed in ground with no sharp edges
- Exclusive grate design with welded bars and tamper-resistant screws
- Sanitary continuous-flushing rim and covered corners
- Remotely flushed

BARIATRIC TOILETS & SQUAT PAN



HW-2125-A Bariatric on-floor with toilet seat. White powdercoat shown. *Not suitable for high-security settings.*



2105BAR-W-1-CN
Front-mount, off-floor bariatric toilet model features a Bariatric Adjustable Fixture Support from Jay R. Smith Mfg. Co. (Figure Number 0210Y-M54-XK Bariatric Duty, 1000 LBS; Figure Number 0210Y-M54-XX Extra Heavy Duty, 750 LBS).

BARIATRIC TOILET

Morbidly obese patients are a growing part of the correctional population; however, their physical needs are highly specialized. Acorn Engineering's Bariatric toilets and wall supports fulfill the changing needs of correctional institutions. Choose from:

Off-the-Floor Solutions Our partner company, Jay R. Smith Mfg Co. has been a leader in manufacturing closet supports for the bariatric industry. Currently we provide two types of closet supports: one rated for 750 lbs. and the other for 1000 lbs. Acorn's 2105 series stainless steel toilet is designed to work specifically with these carriers.

On-the-Floor Solutions This particular toilet is available with both a floor and wall outlet with an elongated bowl. This heavy duty stainless steel toilet can withstand loads up to 2,000 lbs. with no measurable deflection and loads up to 5,000 lbs. with no permanent damage.

Both toilets can use the optional Big John® hinged toilet seat that is rated for 1,200 lbs. (Not recommended for high security areas)

- **Meets all ASME codes**

INTERNATIONAL SQUAT PAN

The squat toilet is made from heavy-gage, type 304 stainless steel with exposed surfaces polished to a finish. Includes rinsers.

- Heavy-gage type 304 stainless steel
- Satin-polished finish
- Recessed floor design



Squat Pan for international use (1698)



STAINLESS STEEL LAVATORIES / BASINS





Penal-Ware® Lavatory shown with front push button and bubbler (1652-1-BPH-O4-M-DMB_BPH)



Penal-Ware® Lavatory (1652FA-1-BPH-04-M)

LAVATORIES/BASINS

- 14-gage, type 304 stainless steel
- Seamlessly hand-welded with a satin finish
- ADA-compliant models available 
- 100% lead free bubbler 

Available Lavatory Valve:

- Air-Control pneumatically operated, pushbutton valve with additional bubbler control valve as an option



Penal-Ware® Comby with an oval basin

A variety of shape, inset dimensions, and options from which to choose

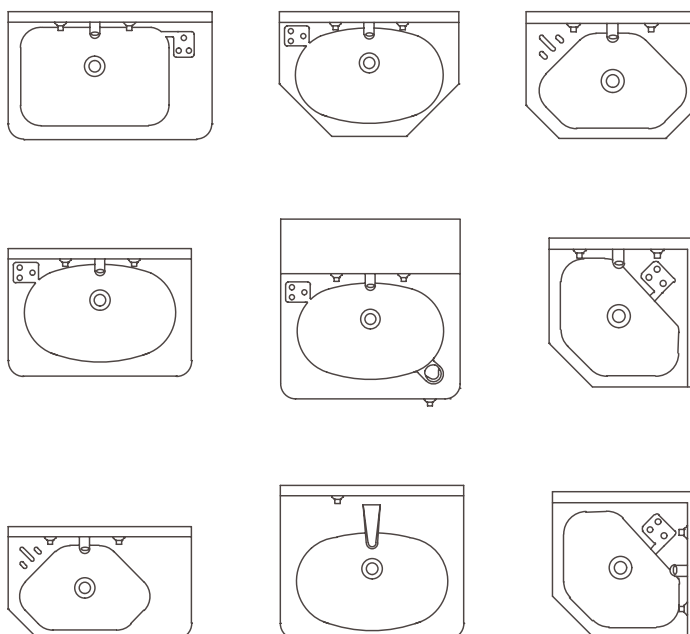

STAINLESS STEEL URINALS



Dura-Ware® Pint-Flow Urinal (2158-W-1-FV)



Dura-Ware® Waterless Urinal (2159)

URINALS

- Heavy-gage, type 304 stainless steel
- Seamless welding—no accessible voids or crevices where contraband can be concealed
- Satin finish on exposed surfaces

STANDARD WASHOUT URINAL (1.0 GPF)

- Vandal-resistant, seamless welded construction
- Heavy gage, type 304 stainless steel
- Reduces facility's overall water consumption and contributes toward LEED certification points
- Easy access for service and installation
- IAPMO certified

PINT-FLOW URINAL (0.125 GPF)

- Vandal-resistant, seamless welded construction
- Heavy gage, type 304 stainless steel
- Reduces facility's overall water consumption and contributes toward LEED certification points
- Easy access for service and installation
- IAPMO certified

WATERLESS URINAL

- **Does not require messy or expensive chemical cartridges**
- One-way diaphragm creates a sealed barrier to block odor
- Will not degrade when flushed with water or common cleaning solvents
- IAPMO Classified
- Reduces facility's overall water consumption and contributes toward LEED certification points

PENAL-WARE®/CORRECTIONAL ACCESSORIES



Bookshelf with Auto-Release Clothes Hooks (1824)



Elmdor® Detention Cabinet (SLA12x12)



Detention Extinguisher Cabinet (DC1704-F)



Detention Hose and Valve Cabinet (DC1815-F)

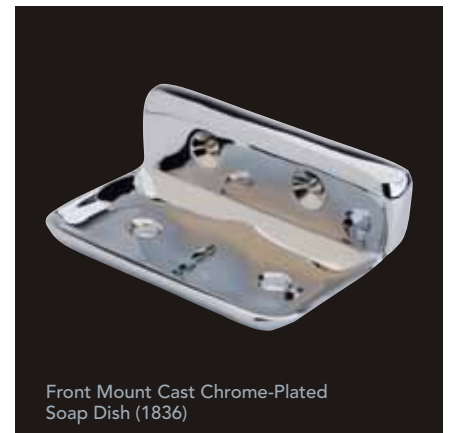

Front Mount Cast Chrome-Plated Soap Dish (1836)

PENAL-WARE®/CORRECTIONAL ACCESSORIES



Auto-Release Clothes Hook (1829)



Recessed Shelf (1820)



Recessed Soap Dish (1832)



Recessed Paper Holder (1840)



Auto-Release Clothes Hook Panel (1828)



Integral Frame Mirror (1817)

SUICIDE RESISTANT FEATURES

AUTO-RELEASE HOOKS support garments, towels, and other lightweight accessories, but break away into a downward position should excessive weight be applied

GRAB BARS are optionally available with a heavy-gage closure plate welded to the bottom of the bar for suicide resistance (-GBC)

Grab bars are ADA-compliant and meet or exceed ANSI, UFAS, and ADA  requirements for structural strength

STAINLESS STEEL SHOWERS



Penal-Ware® Penal Pak Shower (1741-03-RD)



Custom Penal-Ware® Penal Pak Shower (1743-04-M-RD)

WALL SHOWER

- Penal-Ware® showers have been used consistently in correctional facilities for over 45 years
- Showerhead is threaded into rear-mounted body and locked in place. Spray pattern can only be changed with an allen wrench
- Hand shower available as an ADA option, and features a stainless steel quick disconnect hose 

WATER-SAVING SHOWERHEAD OPTIONS 
Low-flow 1.4, 1.6, and 2.0 gpm optionally available



Custom Correctional Shower Cabinets

STAINLESS STEEL SHOWERS / BASES



Penal-Ware® stainless steel ADA shower cabinet (1736)



Modified stainless steel shower base



Terrazzo® shower base (SBS-36-3F)

CABINET SHOWER

Penal-Ware® Security showers are constructed of heavy-gauge, type 304 stainless steel and come with a variety of options to make service and installation easy, even in retro-fit projects.

- Horizontal, vertical, angled, and top closure options serve as finishing strips to join a shower with a wall, ceiling, or two cabinets together. These conceal gaps and protect against accessible voids or crevices
- Can be ordered as knock-down units to allow for easy handling through existing doors, and are ideal for remodel installations
- ADA model comes complete with a flexshower, grab bars, and a stainless steel seat 

WATER-SAVING SHOWERHEAD OPTIONS 
Low-flow 1.4, 1.6, and 2.0 gpm optionally available

STAINLESS STEEL SHOWER BASE

- Slip-resistant matte finish on shower floor
- Integral drain and tiling flange to form permanent water barrier
- Heavy stainless steel reinforcing
- Sound deadened with fire resistant material

TERRAZZO® SHOWER BASE

- **Terrazzo-Ware™ Model Option:** A one-piece, pre-cast design made from marble chips and Portland cement, ground smooth and sealed for durability and protection. Available in a variety of color choices for mop sinks and shower bases
- ADA compliant 
- Stocked product

STAINLESS STEEL ADA PRODUCTS



Modified stainless steel Penal-Ware® ADA Comby (M1432)  shown with dual 1817 mirrors



Modified stainless steel Penal-Ware® ADA Comby (M1435) 

SPECIFIED PRODUCTS, SPECIFIC NEEDS

Acorn Engineering has over 50 years of experience manufacturing products to address specific needs in the correctional market. Products are designed with consideration to all security requirements, from low- to high-risk, and address safety without compromising reliability and convenience. From the smallest details in accessories to models specially engineered for ADA compliance and strength requirements, Acorn has a solution.

ADA-COMPLIANT MODELS

ADA-compliant models are available or can be custom engineered to fit the exact dimension or layout of a cell and chase setup. These units meet all the same ANSI and UFAS requirements as standard models.



Modified Penal-Ware® cabinet shower with ADA Auto-Release Flex Shower (1741ADA) and grab bars. For low security applications. 

CUSTOM ENGINEERING /ENVIRO-GLAZE®



Stainless steel Penal-Ware® Comby (1418-CT-2-BPH-04-M-FV-PH-SPS)

CUSTOMISED SOLUTIONS

Acorn Engineering specializes in custom manufacturing. We offer personal customer service, collaboration, and follow-up on every project. From a single source manufacturer comes integrated products at a perfect fit to match any budget.

ENVIRO-GLAZE® POWDER COATING

Enviro-Glaze® is a durable, electro-statically sprayed powder-coating, applied to stainless steel and then cured at temperatures of 375 degrees Fahrenheit. The finish then becomes an integral part of the stainless steel surface and will not bubble or peel. Acorn Engineering's optional Enviro-Glaze® finish creates a corrosion- and chip-resistant surface that is easily cleaned, maintained, and kept in sanitary condition.



Standard Enviro-Glazed toilets are manufactured with a powder-coated bowl.

Left: White Enviro-Glazed toilet shown with an optional satin finish stainless steel bowl interior.

DRINKING FOUNTAINS / COOLERS / DRAINS



Drinking bubbler assembly (1674-BP-03) Stainless steel security drinking fountains (A112408B-FG-VR)



Modular Stainless Steel Trench Drain Series (9660)



Detail of vandal-proof trench drain bar grate

WATER COOLERS

Acorn Engineering offers sink-top and wall-mounted drinking bubblers, as well as a variety of drinking fountains and water coolers.

- Vandal-resistant, seamless welded construction
- 14-gage, type 304 stainless steel
- Satin finish on exposed surfaces
- ADA, 2 and 3 station model options available 
- 100% lead-free bubbler standard



LEAD-FREE
Certified to **AB1953** and **ANSI (NSF Sec.9, Annex G)**

JAY R. SMITH DRAINS



Smith Modular Stainless Steel Trench Drains are perfect for kitchens, food handling areas, showers and bathrooms, and other areas of correctional facilities where hygienics, corrosion resistance, and visibility are inherent.

- Comprised of 23 modular channel sections to maintain positive drainage and provide design flexibility
- 16-gage, type 304 stainless steel
- Vandal proof bar grate, figure # 9660-466-SBG available for correctional institution installations



CASE STUDY

Stainless Steel vs. Porcelain (Chino State Prison)



Acorn Engineering's stainless steel basin takes a beating but stays strong where porcelain can't.

LAST SINK STANDING

Proper stainless steel prison fixtures can curb riots like those at Chino State Prison

A riot erupted at the California Institution for Men in Chino on August 9, 2009, and when guards finally regained control four hours later, at least 175 inmates were injured and 55 hospitalized. A fire broke out, sinks were ripped from the walls, and many of the facility's fixtures were used as weapons. "It looks like they destroyed anything they could get their hands on," said Lt. Mark Hargrove, a spokesman for the prison, to the Associated Press. "They broke out windows, they pulled out water pipes, they broke off toilets and sinks, they tore doors off their hinges, and they broke metal bunks that are secured to the floor by bolts." The final damage to housing units reduced the prison's ability to house 1,100 inmates, who were transferred to other California prisons. The California corrections chief estimated a \$5 to \$6 million cost to begin clean-up and repairs on the facility.

Porcelain and china are words typically associated with fragile, breakable products—not a preferred characteristic in a correctional facility. A majority of these security and property damage costs could have been prevented simply by installing vandal-resistant stainless steel wash basins, showers, and toilets instead of porcelain or china fixtures. Durable, heavy-gauge stainless steel fixtures, such as found in Acorn Engineering's Penal-Ware® line, are virtually indestructible, and able to withstand up to a 2-1/2 ton load (depending on the fixture) without damage. These prod-

ucts, including wash basin/toilet combination units, toilets, urinals, security showers, drinking fountains, and sinks, are made from unified pieces welded together as one seamless unit. This means that, besides being able to withstand high levels of impact, there are no removable parts that can be broken off and used to inflict injury. The rounded design lacks any sharp edges, so inmates are also unable to fasten anything around the parts, thus taking the control out of the hands of the prisoners.

\$5 to \$6 million in repair costs is a huge blow to a prison's budget. A large percentage of these costs are preventable by updating facilities with high-security products from Acorn Engineering Company. With over 50 years of experience in the correctional plumbing industry, we provide savings in cost, environment and, most of all, safety.

STAINLESS STEEL VS. PORCELAIN

- Vandal-resistant and virtually indestructible
- Prevents injury/promotes safety
- Eliminates possibility for costly damages
- Sterile material
- Recycled stainless steel material is ecologically responsible



MASTER-TROL®

Electronic Water Management System

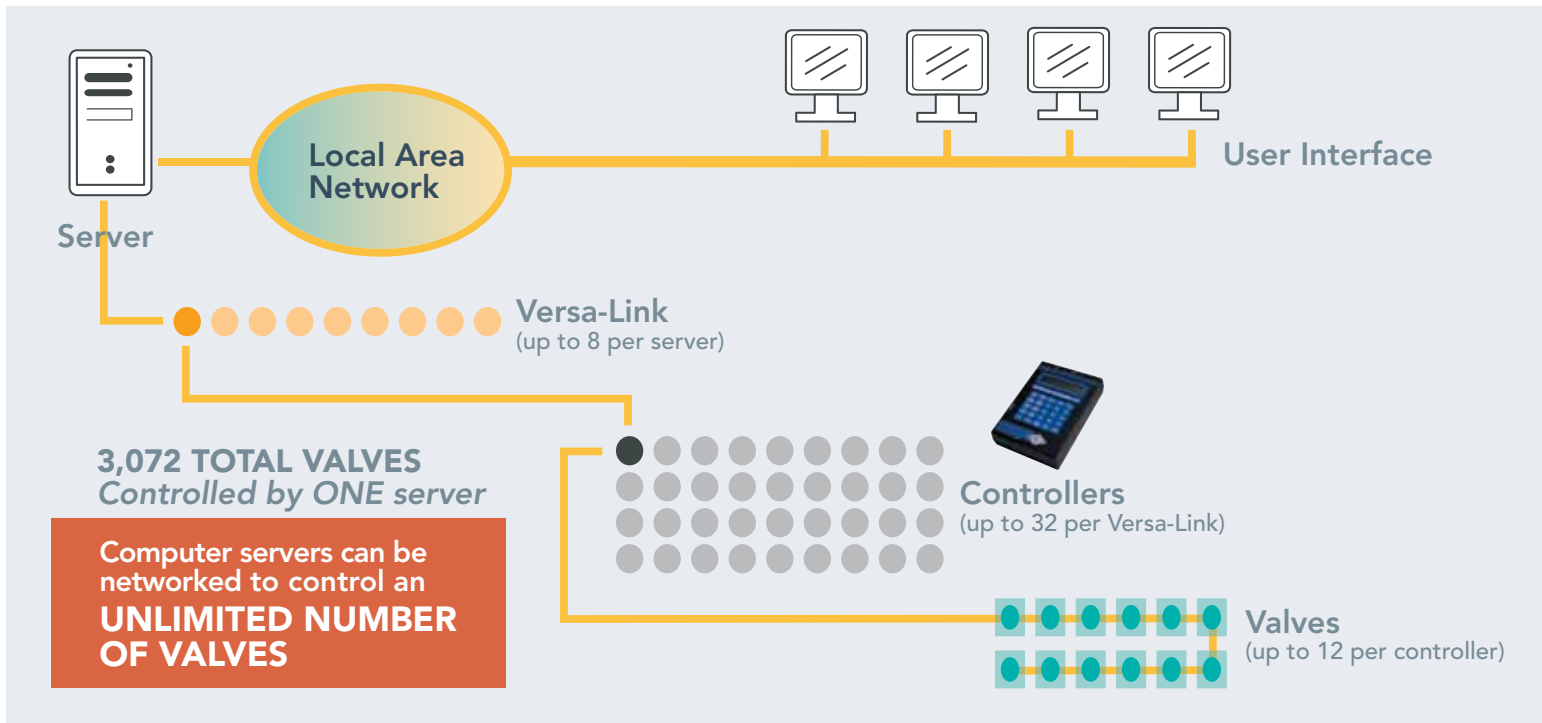

Master-Trol electronic valve system integrates and is scalable with your installation. Easy to use and install.

WATER USAGE, CONTROL, AND VISIBILITY

Master-Trol® is an electronic water management software system used to regulate and provide complete control over all plumbing fixtures in a facility. Since its development in 1991, Master-Trol has been used to address cell flooding, water usage, control, visibility, and maintenance issues. With Master-Trol, each valve in every fixture can be preprogrammed or controlled via a local area network to monitor and restrict use. It enables the operator to set the number of flushes allotted within a time period, and to specify when and for how long a water faucet or shower is to remain active. Floods are thus eliminated, along with unexpected disruptions and windows of opportunity for incidents that can tax a facility's staff and decimate a budget.

Master-Trol is also a proven tool in reducing inmate water usage and improving the sustainability of a facility. California's **San Quentin state prison reports that a single inmate flushes a single toilet 35 to 65 times per day**, whereas a toilet in an average household flushes only 12 times per day.* Master-Trol allows the facility to limit the number of flushes and monitor water consumption by reports, graphs, and charts, allowing for calculated water savings. This ultimately leads to a reduction in overall water usage in correctional facilities and savings in utility costs.

*Correctional News, November/December 2009

- Monitor up to 3,072 valves per server/computer simultaneously from remote computers in multiple locations. Multiple servers can be linked to increase system capacity
- Enable or disable multiple water valves
- Increase or decrease metering times
- Increase or decrease lockout times
- Real-time reporting of water use and reduction
- Prevents floods or abuse of water privileges
- Contributes to LEED points toward US Green Building Certification
- Easy navigation with detailed location descriptions and search
- Regulates use and contributes to overall reduction in water consumption
- Electronic valve
- **Complete control during lockdown with ability to control 1 cell, 1 cell block, or complete facility without leaving a "last flush" (typical with gravity systems).**

VALVE OPTIONS

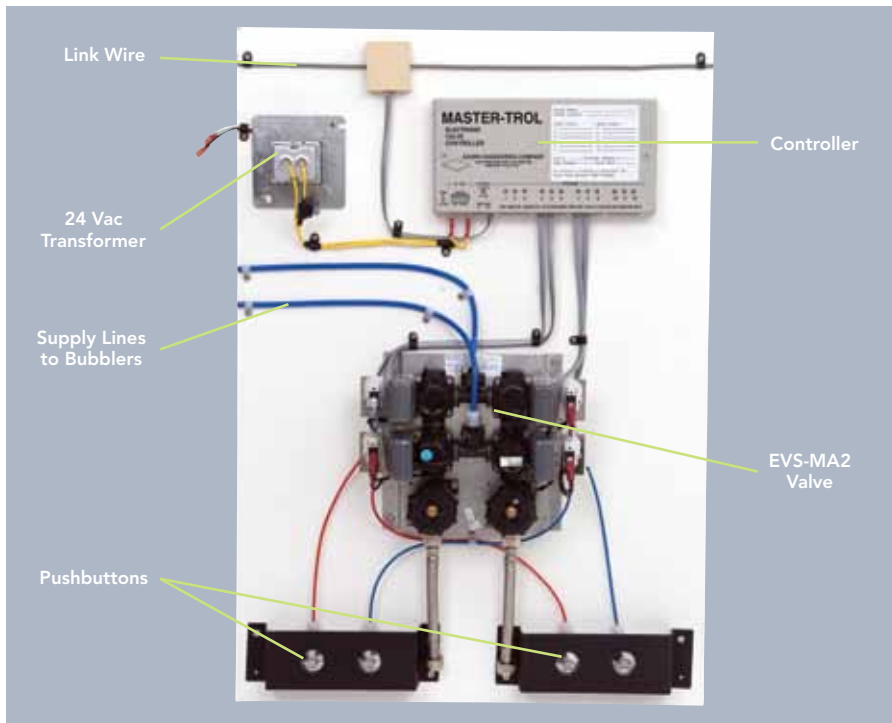

Master-Trol® controllers regulate 12 valves each, and can be linked together in the chase to control up to 3,072 valves from a computer network (standard configuration).

Time-Trol® valves may be located near the fixtures or at a central location up to 100 feet away.

VALVES

Acorn Engineering valve options create different levels of control over fixture and water use. From vandal-resistant pushbutton valves to electronic water management valves, Acorn Engineering allows a facility to select the correct level of security. At the same time, water use can be monitored and conserved.

AIR-CONTROL VALVES

- Can be remotely located and are ideally suited for small chase areas
- Features pushbutton activation
- Provided with a stainless steel strainer and an integral checkstop (-03 single temp and -04 hot and cold model numbers)
- Available in non-metering or metering (-M) options

TIME-TROL® MODULAR VALVE CONTROLLER

- **Metering Valve Mode** limits duration of use
- **Cycle Interrupt** feature sets interval time between uses ranging from 1 second to 9 minutes
- LED light indicates activity and allows for easy troubleshooting
- Located at point of use or up to 100 feet away (uses low-voltage 24 VAC power)
- Electronic valve



All Acorn valves conform with NSF lead-free requirements

Acorn Engineering also offers certified lead-free Brass Valves



WHY VACUUM PLUMBING

Vacuum Plumbing System



WHAT IS AN ACORNVAC VACUUM PLUMBING SYSTEM?

Vacuum plumbing systems are simple and viable alternatives to underground piping, and use the combined energies of vacuum pressure and gravity for the collection, conveyance and disposal of waste through a piping network that can be routed above ground.

Vacuum drainage operates on the principal of having a majority of the plumbing system under a continuous vacuum. Hundreds of vacuum drainage systems are in operation around the world and are accepted by most code authorities. Vacuum systems are a viable drainage solution as noted in the latest edition of the IPC and UPC Codes. In addition, many local and state plumbing codes have also accepted vacuum plumbing as an approved alternative for a variety of waste types including condensate, grey water, sanitary waste, and grease waste.

THE ENVIRONMENTAL CHOICE

A typical vacuum system can reduce potable water consumption for toilets by 68 percent with a highly efficient vacuum flush toilet requiring only a half gallon per flush. Of the many benefits vacuum plumbing offers, the water and waste treatment savings are two of the most important features of this technology. The water savings can be thousands of dollars and millions of gallons per year for larger applications.

“AcornVac®, in combination with other conservation efforts throughout the new facility, contributed to a reduction in potable water use by a remarkable 56% and lowered sewage conveyance by nearly 70% through a state-of-the-art vacuum plumbing system.”

- California Department of Corrections on the AcornVac System installed at Salinas Valley State Prison Medical Treatment Center



HOW IT WORKS

Vacuum Plumbing System

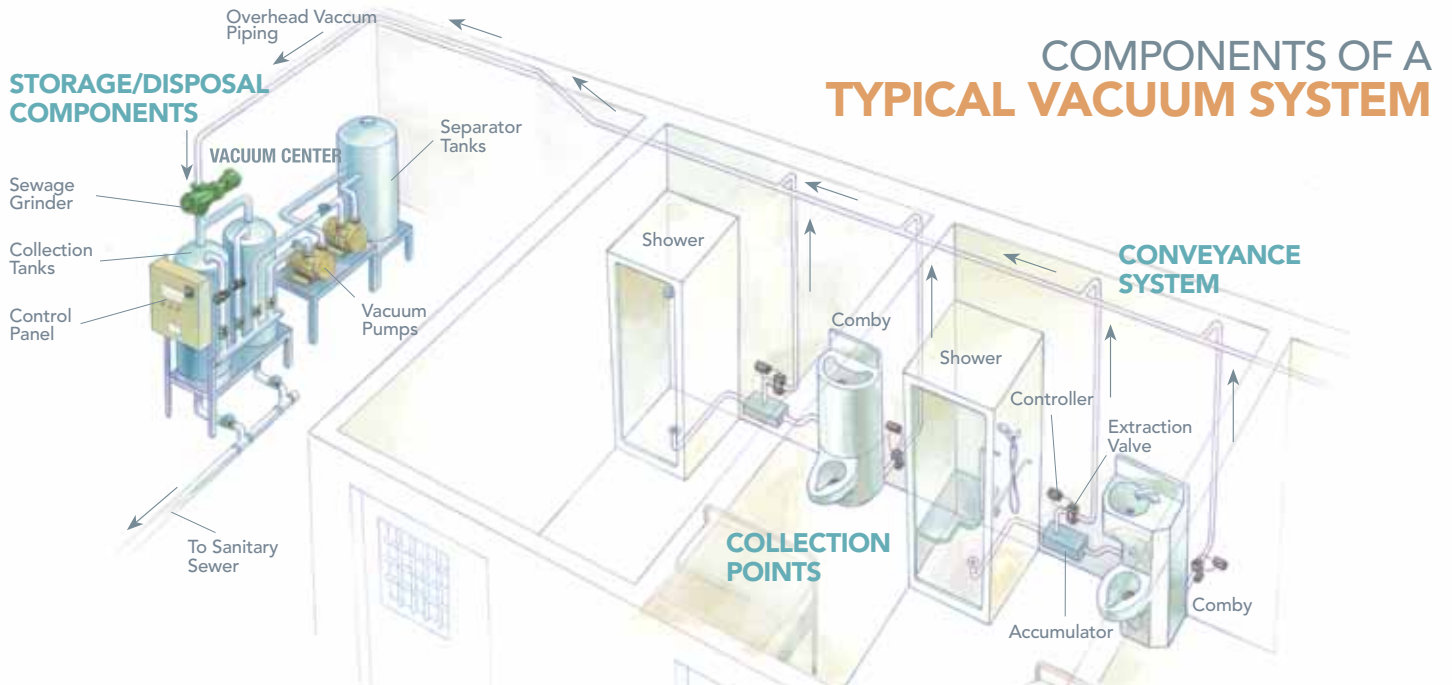

For illustration purposes only

AN INTRODUCTION TO VACUUM SEWAGE AND PLUMBING SYSTEMS

There are **three primary components** in a vacuum plumbing system:

Vacuum Interface Valves and Intermediate Waste Collection Points

The vacuum interface components allow waste to be introduced into the vacuum waste piping network and transported to the vacuum center. These components include a normally closed Extraction Valve, which separates the vacuum in the piping from atmospheric pressure surrounding the fixture, and a Controller, which operates the Extraction Valve.

The water closet Extraction Valve is connected to the waste outlet, separating the toilet from the piping network. When the flush valve is activated, the Controller opens the Extraction Valve, allowing atmospheric pressure at the toilet bowl to push waste to the waste outlet, through the Extraction Valve, and into the waste piping. Because air is used to transport wastewater, no water is required to initiate the flush cycle. The Controller also activates the flush water valve for rinse and refill of the bowl. The opening and closing of the Extraction Valve is precisely controlled so that all waste is completely removed from the bowl.

In the case of urinals, flushing sinks, and any other non-flushing fixture, the waste drainage process is similar, but typically includes the use of an intermediate waste collection point, or Accumulator.

Conveyance System (The Vacuum Waste Piping Network)

The vacuum waste piping or conveyance system is a closed piping network that is typically maintained under a continuous vacuum pressure and is generally fabricated out of standard pressure rated PVC, Copper, or other smooth bore, non-porous material. The piping network consists of "risers" or "droppers" that transport the collected waste vertically from the point of origin to horizontal mains and branches leading to the Vac Center.

Vacuum Generating, Waste Collection, and Disposal Components (The Vacuum Center)

Commonly referred to as the "Vac Center," the vacuum generating station includes vacuum pumps to create a continuous vacuum pressure within the piping network, and storage tanks that collect and discharge the waste into the facilities' sewer main. In the case of sanitary waste, the Vac Center waste storage tanks are directly connected to sanitary sewer waste lines. Waste travels under vacuum pressure from the fixture, through the piping network, and into the Vac Center waste storage tanks, where it is temporarily held before discharge to sanitary waste lines or treatment equipment.



INSTITUTIONAL CONSTRUCTION BENEFITS

Vacuum Plumbing System



Acorn Engineering provides enhanced security and control for correctional facilities.

DESIGNED TO FIT MOST ANY CONSTRUCTION CHALLENGE

- Direct connection of multiple toilets into the same waste stack is eliminated, thereby preventing inmates from passing contraband between cells.
- Vacuum toilets eliminate cell-to-cell communication that inmates often use to create "planned plumbing chaos" by organizing large "group flushes" that are typical for gravity drainage systems.
- The operational dynamics of a vacuum plumbing system result in fewer main line blockages, reducing maintenance cost and disruption. When toilet blockages do occur, they are easily located at the fixture, rather than within the waste line. This feature allows staff to easily identify inmates who routinely try to vandalize the plumbing system, promoting significantly improved security and control.
- In conjunction with an electronic water management system such as Master-Trol, individual cells or groups of cells can be "turned off" prior to a security sweep. This prevents contraband or other incriminating evidence from being flushed away.
- Vacuum flush toilets do not splash during the flush cycle, significantly reducing the spread of bacteria within the facility, promoting a healthier environment for staff and prison populations.

"AcornVac is a powerful money saver. For starters, we cut the Authority's waste cost by \$200,000 a year. We saved \$400,000 up front in domestic water connect fees because AcornVac's smaller piping network simplifies everything, and we drastically reduced how the inmates control the jail by eliminating clogged pipes."

- John Chaney
AECOM HSMM Project Manager
Western Virginia Regional Jail
Salem, Virginia



CASE STUDY

Western Virginia Regional Jail



With the help of AcornVac, this jail was able to address local concern with environmental impact and reduce annual water and sewage costs.

WESTERN VIRGINIA REGIONAL JAIL

AcornVac® eliminates contraband and floods, and contributes to an 11 million gallon water usage reduction

This 264,000 square-foot, 605-bed correctional facility is considered one of the most modern, safe, and cost-effective jails of its kind. But no achievement on this scale is without the typical challenges faced in any facility. Contraband, floods, and water use reduction were all of concern.

Acorn Engineering and subsidiary AcornVac came into the project early on as a consultative supplier. Working in conjunction with a Master-Trol® electronic valve control system, the jail staff is better able to prevent inmates from disrupting operations by toilet fixture abuse or contraband sharing. What's more, the water savings provided totaled nearly 11 million gallons of water per year, due largely in part to the AcornVac Vacuum Plumbing System. With this exemplary performance, a LEED innovative design (ID) credit was achieved.

AcornVac is honored to have been selected by the Jail Authority and the Roanoke Office of AECOM Technology Corp. as a sole-source supplier for the vacuum plumbing system and fixtures.

Because of their achievement, AECOM earned a 2009 Engineering Excellence Honor Award from the American Council of Engineering Companies (ACEC). AcornVac is proud to have collaborated on this project.

FACILITY OF THE MONTH

JULY/AUGUST 2009 ISSUE OF CORRECTIONAL NEWS

HONOR AWARD

AMERICAN COUNCIL OF ENGINEERING COMPANIES

"Ultimately, AcornVac provided collaboration, document review, and analytical support during the entire design process. They were very responsive to the project's unique nature and design schedule."

Mark Thayer
CPD, AECOM Technology Corp.



CHRONOMITE®

Tankless, Instantaneous, Point-of-Use Water Heaters

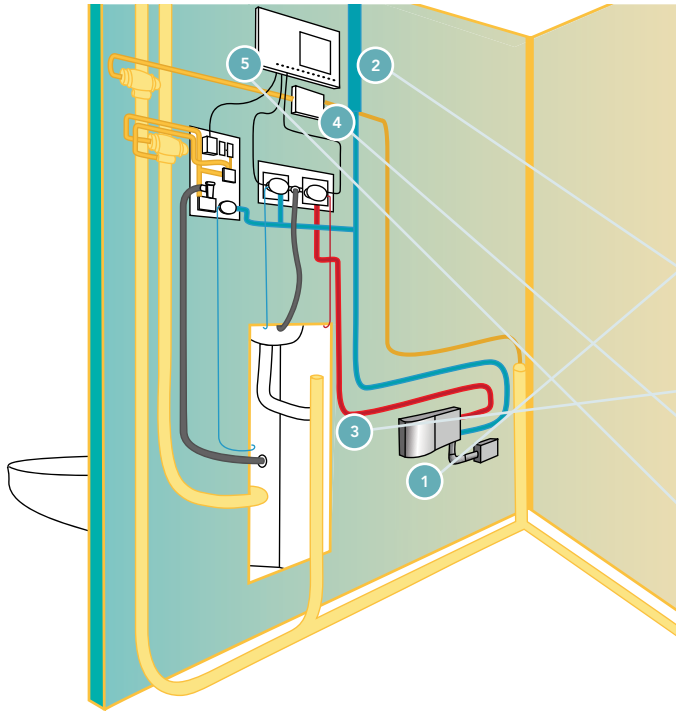

INTEGRATING WATER-SAVINGS AND HEATERS

- 1 CHRONOMITE® TANKLESS WATER HEATER
fits perfectly behind a chase—eliminates the use of large water heaters
- 2 COLD WATER IN
- 3 HOT WATER OUT
- 4 PNEUMATIC CONTROLLER
- 5 MASTER-TROL® PANEL

Left: A typical chase utilizing a Chronomite heater.
Up to two Penal-Ware® Combys can work with each Chronomite unit

HIGH SECURITY, LOW IMPACT

Chronomite® manufactures tankless water heaters for on-demand, point of use applications. Patented microprocessor technology allows the unit to preset to a specific temperature to prevent scalding, and is self-cleaning, so there is little maintenance required. The units are only operational when hot water is requested at 99 percent energy efficiency, thereby reducing hot water delivery time. Plus, it's only the size of a standard dictionary.

CASE STUDY

Henderson State Penitentiary (Nevada) uses (1) Chronomite heater per two Penal-Ware® Combys. This particular project used 50 heaters.

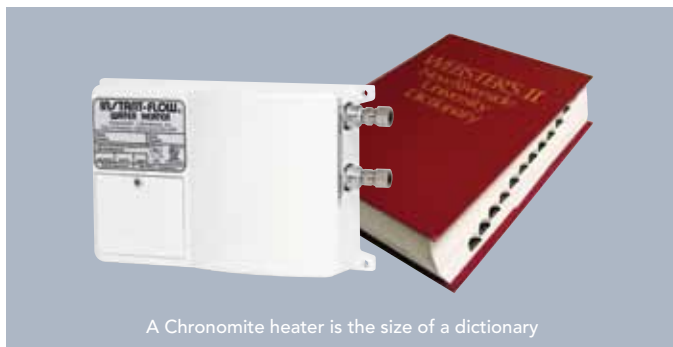

USE ONLY WHAT YOU NEED TO HEAT

- On-demand hot water at 99% energy efficiency
- Supply places with limited space and unreachable access—perfect for a guard tower or a chase
- Lower maintenance and operational costs 💰
- Reduced hot water delivery time saves water
- Compact size
- Anti-scalding pre-set temperature

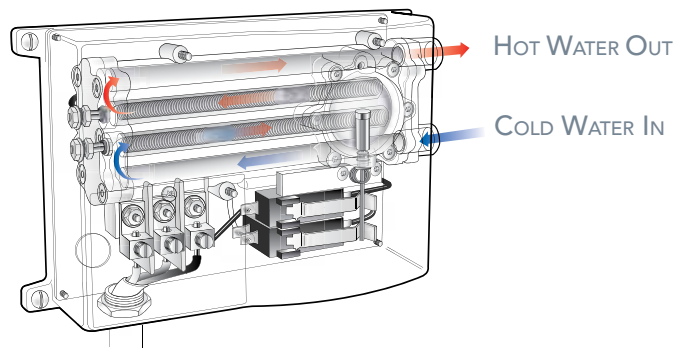

WATER SAVINGS

Flush Calculation Charts



Strive toward LEED water saving points with Acorn's water saving products *Here are some typical correctional scenarios:*

20 flushes per day unlimited for a 16-hour period (typical time inmate is awake) with a 1.6 gpf flush valve

20 flushes x 1.6 gpf x 1 person = 32 gallons per person a day
20 flushes x 1.6 gpf x 100 people = 3,200 gallons per day
20 flushes x 1.6 gpf x 1,000 people = 32,000 gallons per day
11,680,000 gallons a year per 1,000 people

Master-Trol with a 1-hour (maximum) lockout for a 16-hour period (typical time inmate is awake) with a 1.6 gpf flush valve

16 flushes x 1.6 gpf x 1 person = 25.6 gallons per person a day
16 flushes x 1.6 gpf x 100 people = 2,560 gallons a day
16 flushes x 1.6 gpf x 1,000 people = 25,600 gallons a day
9,344,000 gallons a year per 1,000 people. 20% Savings!

Master-Trol with a 24-hour limit of 6 flushes/day & a 1.6-gpf flush valve

6 flushes x 1.6 gpf x 1 person = 9.6 gallons per person a day
6 flushes x 1.6 gpf x 100 people = 960 gallons a day
6 flushes x 1.6 gpf x 1,000 people = 9,600 gallons a day
3,504,000 gallons a year per 1,000 people. 70% Savings!



Master-Trol with a 24-hour limit of 6 flushes per day combined with an AcornVac Vacuum System that utilizes a .5 gpf toilet

6 flushes x .5 gpf x 1 person = 3 gallons per person a day
6 flushes x .5 gpf x 100 people = 30 gallons a day
6 flushes x .5 gpf x 1,000 people = 3,000 gallons a day
1,095,000 gallons a year per 1,000 people. 90% Savings!





Est. 1954

ACORN ENGINEERING COMPANY

Manufacturers of Engineered Plumbing Products

Mailing:
P.O. Box 3527
City of Industry, CA 91744 U.S.A.
800-488-8999 • 626-336-4561

Street Address:
15125 Proctor Avenue
City of Industry, CA 91746

Fax: 626-961-2200
International Fax: 1-626-937-4757
Web: www.acorneng.com

DISTRIBUTION CENTERS

Florida
8306 N.W. 14th Street • Doral, FL 33126
866-961-3473 Fax 866-960-0844

Georgia
4103 Tench Road, Suite 100
Suwanee, GA 30024
800-762-0542 Fax 888-249-8002

Illinois
1350 N. Michael Drive #B
Wood Dale, IL 60191
800-547-3473 Fax 630-766-4609

New Jersey
1480 Ridgeway Street • Union, NJ 07083
800-526-4592 Fax 908-964-9056

Texas
1500 Precision Dr. Suite 120 • Plano, TX 75074
866-644-3473 Fax 972-516-1888

PARTNER DISTRIBUTION CENTERS

ACORN F&M Mexico
Maquiladoras 1387-1, Col. Cd. Industrial
Tijuana, B.C. C.P. 22444

ACORN/POWELL, LTD United Kingdom
5 Brearley Court • Baird Road
Quedgeley, Gloucester GL2 2AF United Kingdom
01452-721211 • Fax 01452-721231
www.acornpowell.co.uk

ACUDOR/ACORN, LTD Canada
1125 Squires Beach Road
Pickering, Ont. Canada L1W3T9
905-427-9957 • Fax 905-427-7534
www.acudoracornltd.com

JAY R. SMITH MFG. CO. Alabama
P.O. Box 3237
Montgomery, AL 36109-0237
800-467-6484 Fax 334-272-7396

ELMCO/STEWART Arizona
3201 W. Virginia Ave., Suite 5
Phoenix, AZ 85009
602-269-0585 Fax 602-278-2567

ELMCO/DUDDY Southern California
• P.O. Box 3787 • City of Industry, CA 91746
626-333-9942 Fax 626-855-4811
• 9750 Birch Canyon Place • San Diego, CA 92126
858-437-0112 Fax 858-437-0117

ELMCO/FORD Las Vegas
5022 Bond St. • Las Vegas, NV 89118
702-871-1966 Fax 702-871-2686

ELMCO & ASSOCIATES Northern California
8366 Valdez Avenue • Sacramento, CA 95828
916-383-0110 Fax 916-383-0181

ELMCO & ASSOCIATES San Francisco
Warehouse
1195 Evans Avenue
San Francisco, CA 94124--1796

ACORN FAMILY OF COMPANIES



ACORN AQUA

Drinking Fountains
P.O. Box 3527 • City of Industry, CA 91744-0527 U.S.A.
800-591-9360 • Fax 626.855.4894
www.acornaqua.com



ACORN-GENCON PLASTICS,LLC

Injection Molded Products
13818 Oaks Avenue • Chino, CA 91710 U.S.A.
909-591-8461 • Fax 909-628-7465
www.acorn-gencon.com



ACORN SAFETY

Emergency Drench Systems
P.O. Box 3527 • City of Industry, CA 91744-0527 U.S.A.
800-591-9360 • Fax 626-937-1213
www.acornsafety.com



ACORN VAC

Vacuum Plumbing Systems
13818 Oaks Avenue • Chino, CA 91710 U.S.A.
800-591-9920 909 902-1141 • Fax 909-902-5041
www.acornvac.com



CHRONOMITE LABORATORIES, INC.

Tankless Electric Water Heaters
P.O. Box 3527 • City of Industry, CA 91744-0527 U.S.A.
800-447-4962 • Fax 626-937-4279
www.chronomite.com



ELMDOR/STONEMAN MANUFACTURING

Access Doors and Roof Flashing Assemblies
P.O. Box 3527 • City of Industry, CA 91744-0527 U.S.A.
800-591-9181 626-968-8699 • Fax 626-333-4109
www.elmdorstoneman.com



JAY R. SMITH MFG. CO.

Plumbing, Drainage and Rainwater Harvesting Products
P.O. Box 3237 • Montgomery, AL 36109-0237
800-467-6484 Fax 334-272-7396
www.jrsmith.com



MURDOCK-SUPER SECUR

Pre-engineered Modular Buildings,
Drinking Fountains, Water Hydrants
P.O. Box 3527 • City of Industry, CA 91744-0527 U.S.A.
800-453-7465 626-333-2543 • Fax 626-855-4860
www.murdock-supersecur.com



NEO-METRO®

Luxury Stainless Steel Plumbing Fixtures
P.O. Box 3527 • City of Industry, CA 91744-0527 U.S.A.
800-591-9050 626-855-4854 • Fax 626-937-4725
www.neo-metro.com



POTTER ROEMER

Fire Protection Equipment
P.O. Box 3527 • City of Industry, CA 91744-0527 U.S.A.
800-366-3473 • Fax 626-937-4777
www.potterroemer.com



WHITEHALL MANUFACTURING

Hospital and Therapy Products
P.O. Box 3527 • City of Industry, CA 91744-0527 U.S.A.
800-782-7706 626-968-6681 • Fax 626-855-4862
www.whitehallmfg.com