



Secur-Care® - Ligature Resistant LR2141 Series Ligature Resistant Siphon Jet Toilet



LR2141-W-2-RM

Fixture May Show Some Available Options



Please visit www.acorneng.com for most current specifications.

Ligature Resistant Siphon Jet Toilet

Ligature Resistant Toilet contoured ligature resistant Housing is fabricated from 16 gage type 304 stainless steel and polished to a satin finish. The inside of the Toilet Bowl also has a satin finish. Engineered to reduce possible risk of the fixture being used as a ligature device. Mounting is available for rear installations.

Toilet is a Siphon Jet type with ligature resistant elongated Bowl manufactured to ASME A112.19.3 and CSA B45.4 requirements and will flush with a minimum of 25 PSI flow pressure. P-Trap has a minimum 3-1/2" seal, will and pass a 2-1/8" ball.

Flush Valve supply is available for exposed or concealed Flush Valve styles with 1-1/2" NPT connection. Exposed Flush Valves require ligature resistant Flush Valve Cover.

Rear Mount units include integral 1/2" UNC Anchor Tappings and Mounting Hardware. Unit requires an accessible pipe chase for installation. Waste Outlet connection is a 2-3/8" OD stainless steel plain end.

GUIDE SPECIFICATION

Secur-Care® Ligature Resistant Siphon Jet Toilet (specify model number and options). Fixture to be fabricated from 16 gage, type 304 stainless steel. Exposed surfaces shall be polished to a satin finish. Toilet shall meet ASME A112.19.3 and CSA B45.4 requirements and will flush with a minimum of 25 PSI flow pressure. Toilet P-Trap shall have a minimum 3-1/2" seal that shall pass a 2-1/8" diameter ball and be fully enclosed. Fixture shall withstand loadings of 5,000 pounds without permanent damage.

Secur-Care® - Ligature Resistant LR2141: Siphon Jet Toilet



WALL THICKNESS AND TYPE (Must Specify)

Thickness _____ Type: Concrete Block Steel

MODEL NUMBER AND OPTIONS SELECTION:

BASE MODEL NUMBER

LR2141 Siphon Jet Toilet

SUPPLY SELECTION (Must Specify)

-T Top (Exposed)
 -W Wall (Concealed)

FIXTURE MOUNTING & WASTE

-2 On-Floor, Wall Outlet
 -ADA 18" ADA Integral Seat Height

INSTALLATION

-RM Rear Mount

FLUSH VALVE GPF (Must Specify)

-1.28 GPF (HET)
 -1.6 GPF (Not Available in California)

FLUSH VALVE OPTIONS (Must Specify)

***NOTE: FOR FLUSH VALVE ACCESS PANEL OR COVER REFER TO ACORN OPTIONS MODEL #2898 (-W SUPPLY) OR # 2802 (-T SUPPLY).**

- FV Flush Valve, Mechanical (N/A for Top Supply, Accessory Options or ADA)
- FVBO Flush Valve by Others
- FVH Flush Valve Hydraulic (N/A w/ Top Supply)
- MVCFV Time-trol Electronic FV (N/A w/ Top Supply)

TOILET OPTIONS

- CO1 Cleanout with O-Ring to No-Hub 2-3/8" x 4"
- CO1-3 Cleanout with O-Ring to No-Hub 2-3/8" x 3"
- FG 14 Gage Housing
- FVT Flush Valve Thru-Wall Connection
- GW Gasket Waste
- PC Pinned Cleanout Plug (For CO1 Options)

PRODUCT OPTIONS

- EGE Enviro-Glaze Color Specify: _____ Toilet Exterior Only
- HP High Polish Finish (Exterior Only)
- MT Metal Template
- SW Wall Sleeve
- TF Time-Trol Transformer
- VAC AcornVac System

Please visit www.acorneng.com for most current specifications.

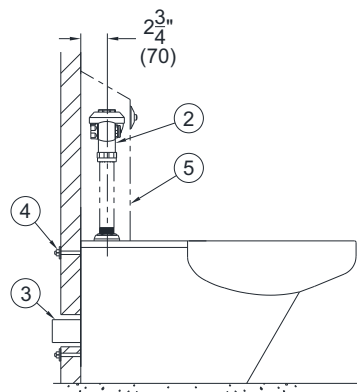
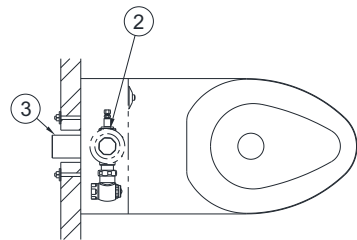

MODEL# LR2141-T-2-RM

NOTES:

1. OPTIONAL -W WALL SUPPLY, -FV FLUSH VALVE
2. OPTIONAL -T TOP SUPPLY, -FVH FLUSH VALVE
3. TOILET WASTE OUTLET
4. 1/2"-13 UNC WALL MOUNTING HARDWARE
5. FLUSH VALVE COVER, DURA-WARE 2802-SLPT-RH SHOWN FOR REFERENCE

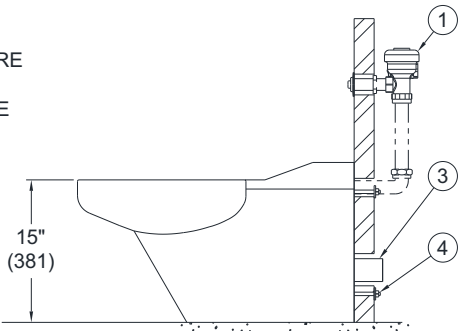
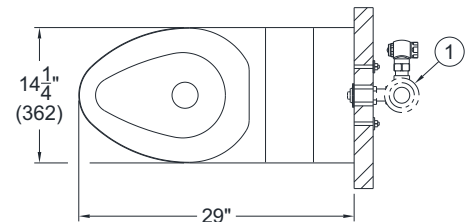

MODEL# LR2141-W-2-RM

WARNING: Cancer and Reproductive Harm - www.P65Warnings.ca.gov

<p>Important: Installation instructions and current rough-in are furnished with each fixture. Do not rough in without certified dimensions. Dimensions are subject to manufacturer's tolerance of plus or minus 1/4" and change without notice. Acorn assumes no responsibility for use of void or superseded data. © Copyright 2009 Acorn Engineering Company</p>	
<p style="text-align: center;">Selection Summary</p> <p>Model No. & Option _____</p> <p>Quantity _____</p>	<p style="text-align: center;">Approved for Manufacturing</p> <p>Company _____ Title _____</p> <p>Signature _____ Date _____</p>