



Portable Wash-Ware® PS1200 Series

Deluxe-Plus Heated. Self-Contained Portable Hand-Wash Station



PS1210 - PS1000-F11 - PS1000-SSO - PS1000-TR - PS1200-SG2

Fixture May Show Some Available Accessories

Please visit www.acorneng.com for most current specifications.

Deluxe-Plus Heated, Self-Contained Portable Hand-Wash Station

Acorn's Deluxe Portable Hand-Wash Station instantly provides hand washing capability and is ideal for use in Emergency Triage Facilities, remote locations, and the entrance to public buildings and restaurants of all types.

The Warm Water, Self-Contained design provides the ultimate remote hand washing experience in the absence of plumbed water and waste by using an available electrical supply. The built-in Electric Water Heater offers users the most effective hand wash by providing a tempered water supply from the self contained water source. Both the water supply and waste water are self contained using Storage Tanks concealed within the cabinet.

Self-Contained Model PS1210 incorporates a Manually Operated Foot Pump to deliver water from the 5-Gallon Fresh Water Storage Tank to the (optional) Gooseneck Spout. The Foot Pump provides the greatest amount of water conservation by allowing users to directly control the water flow used in washing and rinsing. A 6-Gallon removable Wastewater Tank is also provided.

Self-Contained Model PS1230 provides a pressurized water flow from the 5-Gallon Fresh Water Storage Tank to the Faucet using a 110VAC Plug-in, On-Demand Pump. The Pump allows for use with a variety of Faucet styles and offers the user the greatest ease and convenience. Refer to the optional Gooseneck Faucet selections.

Electric Water Heater provides users with warm water for hand washing from a UL listed Mini Tank. The Water Heater supplies Hot Water to a Thermostatic Mixing Valve to blend with the self contained fresh water supply and deliver the tempered supply. The Mixing Valve is ASSE 1069/1070 Certified for scald protection. The Mini Tank meets Lead-Free Standards and conveniently plugs into a 110-120VAC, 15 Amp receptacle.

Optional Gooseneck Faucet selections include a Battery-Operated Hands-Free Sensor, Wrist Blade, or Lever Handle control. A Gooseneck Spout is optionally available when the unit is specified with the PS1210 Foot Pump model. All faucets are single temperature supply, meet NSF and Lead-Free Standards and include a 0.5 GPM (1.9 LPM) Flow Control.

Fresh Water Tanks and Wastewater Tanks are optionally available for additional storage to reduce filling or dumping.

Portable Hand-Wash Cabinet is fabricated of type 304 stainless steel with exposed surfaces polished to a #4 satin finish. A hinged door with Magnetic Door Latch allows access to plumbing and storage components. Oval Lavatory Bowl is 14-1/2" x 9-1/2" x 6" deep, and fabricated from heavy gage type 304 stainless steel, which is polished to a #4 satin finish. A removable grid strainer drain is provided. Countertop is punched for a single hole Faucet with a 1-5/16" diameter opening. Cabinet rim height is available in a 31" -JR Junior Height option. The cabinet includes handles and 3" diameter Swivel Casters for easy mobility with Brake Levers to keep unit stationary during use.

Portable Wash-Ware® PS1200 Series: Portable Hand-Wash Station



MODEL NUMBER AND OPTIONS SELECTION

BASE MODEL NUMBER: (Faucet Not Included)

Self Contained Models

- PS1210** Foot Pump (Manually) Operated, Fresh Water Tank, Wastewater Tank
- PS1230** On-Demand Plug-In Pump, Fresh Water Tank, Wastewater Tank

Faucet / Spout Selections (Optional)

Model PS1210

- PS1000-F11 Gooseneck Spout (Only)

Model PS1230

- PS1000-F21 Gooseneck, Wrist Blade Handle
- PS1000-F31 Gooseneck, Battery Sensor Operated
- PS1000-F40 Gooseneck, Single Handle

Options and Accessories

- JR 31" Junior Rim Height
- PS1000-PH3 3-Bay C-Fold Paper Holder
- PS1000-PS Pump Soap Dispenser
- PS1000-SSO Sensor Operated Soap Dispenser
- PS1000-TR 6-Gallon Trash Receptacle
- PS1200-SG Wrap Around Splash Guard
- PS1200-SG1 Wrap Around Splash Guard, 3-Bay Paper Holder and Soap Bottle Holder
- PS1200-SG2 Wrap Around Splash Guard, 3-Bay Paper Holder
- PS1000-5GF 5-Gallon (19 Liter) Fresh Water Tank (PS1010, PS1030)
- PS1000-6GW 6-Gallon (23 Liter) Wastewater Tank (PS1010, PS1020, PS1030, PS1040)
- WH-DECAL 10" Sticky Decal "Wash Your Hands"

Please visit www.acorneng.com for most current specifications.

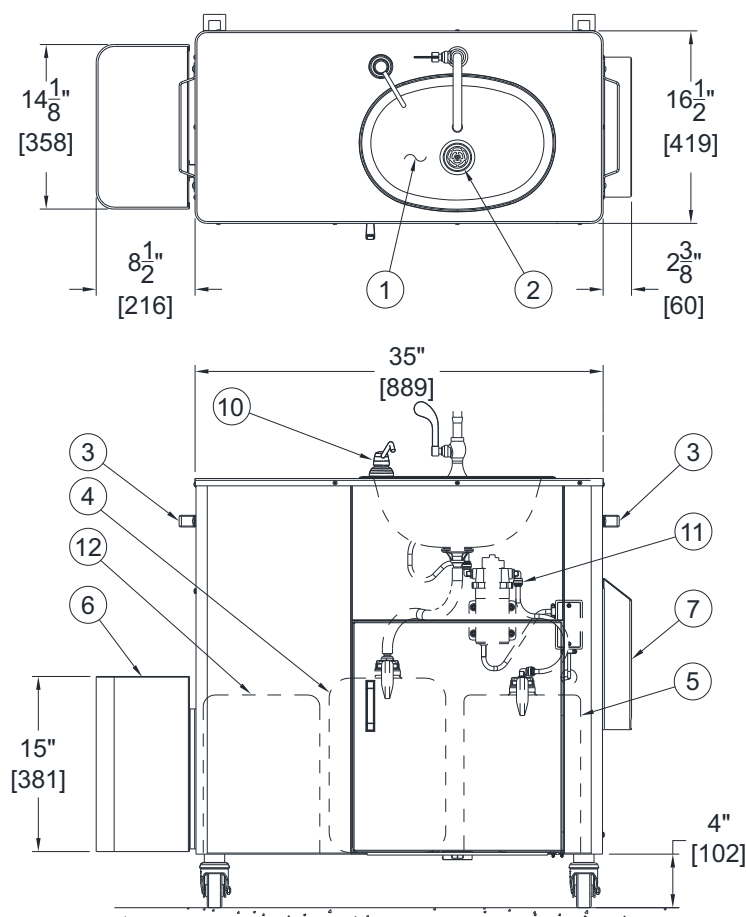

NOTES:

1. OVAL BOWL
2. REMOVABLE GRID STRAINER
3. CART HANDLES (INCLUDED)
4. WASTEWATER TANK
5. FRESH WATER TANK
6. OPTIONAL PS1000-TR TRASH RECEPTACLE
7. OPTIONAL PS1000-PH3 PAPER HOLDER
8. OPTIONAL PS1000-F12 GOOSENECK FAUCET
9. (4) 3" DIA CASTERS (BRAKE LOCKS ON FRONT)
10. OPTIONAL PS1000-PS PUMP SOAP DISPENSER
11. ON-DEMAND WATER PUMP (MODEL PS1230)
12. ELECTRIC WATER HEATER

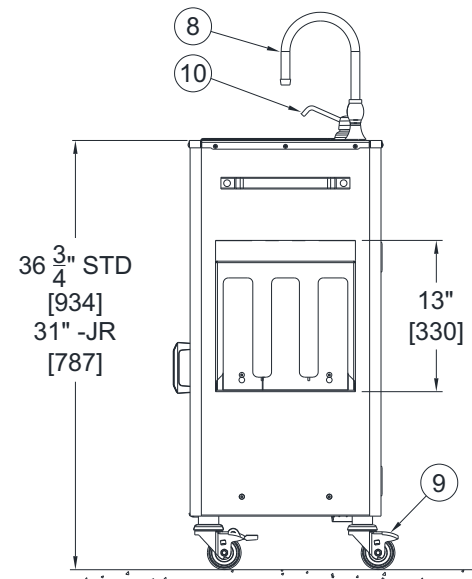

MODEL PS1230 (See notes for options shown)

WARNING: Cancer and Reproductive Harm - www.P65Warnings.ca.gov

<p>Important: Installation instructions and current rough-in are furnished with each fixture. Do not rough in without certified dimensions. Dimensions are subject to manufacturer's tolerance of plus or minus 1/4" and change without notice. Acorn assumes no responsibility for use of void or superseded data. © Copyright 2007 Acorn Engineering Company</p>	
<p style="text-align: center;">Selection Summary</p> <p>Model No. & Option _____</p> <p>Quantity _____</p>	<p style="text-align: center;">Approved for Manufacturing</p> <p>Company _____ Title _____</p> <p>Signature _____ Date _____</p>