



R2115

Siphon Jet Toilet - On Floor

Replacement Toilet for Most Vitreous China Closet Fixtures.

The **R2115 Closet Fixture** is designed to replace a variety of existing front mount on floor fixtures. Unit includes a contoured integral seat with satin finish in addition to punching for hinged seat by others. Unit is fabricated from 16 gage, type 304 stainless steel and is seamless welded construction with exposed exterior & interior surfaces having a #4 satin finish. Units are available with -EGE-10 Snow White Enviroglaze® Powder Coat Finish on exterior (only) of entire unit (interior is stainless steel finish).

Toilet is Siphon Jet type with elongated bowl manufactured to ASME A112.19.3-2008 and CSA B45.4-2008 requirements and will flush with a minimum of 25 PSI flow pressure when used in conjunction with an appropriate flush valve. Trap has a minimum 3-1/2" seal, will pass a 2-1/8" ball and is fully enclosed. Wall flange is reinforced for maximum strength and includes 1-1/2" NPT flushing inlet connection and gasket waste outlet.

GUIDE SPECIFICATION

Provide and install Acorn Replacement Siphon Jet Toilet (specify model number and options). Fixture shall be fabricated from 16 gage, type 304 stainless steel. Construction shall be seamless welded and exposed surfaces shall have a satin finish with an integral contoured toilet seat. Toilet shall be concealed blowout jet type with an elongated bowl and a self-draining flushing rim. Toilet shall meet ASME A112.19.3-2008 and CSA B45.4-2008 requirements and will flush with a minimum of 25 PSI flow pressure. Toilet trap shall have a minimum 3-1/2" seal that shall pass a 2-1/8" diameter ball and be fully enclosed. Toilet waste outlet shall be gasket waste.



Must specify:

- R2115-T-2
 - Stainless Steel Finish
 - Snow White
- R2115-W-2
 - Stainless Steel Finish
 - Snow White

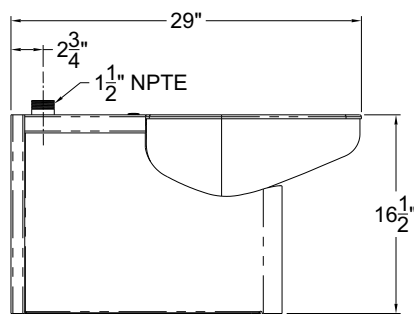

R2115-T-2

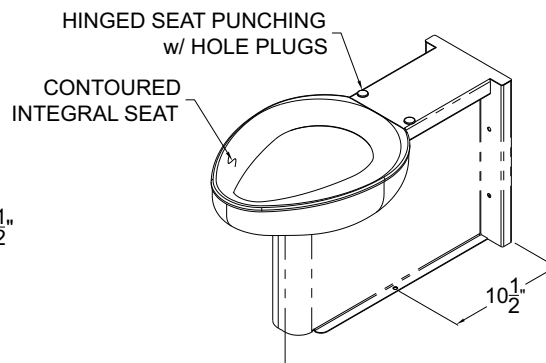

R2115-W-2 SHOWN

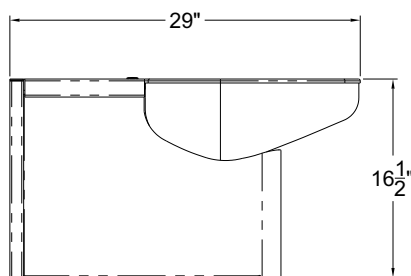

R2115-W-2

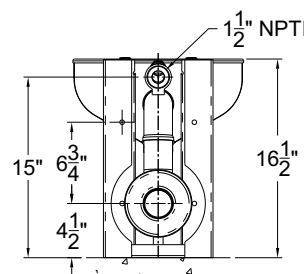

Please visit www.acorneng.com for most current specifications.

WARNING: Cancer and Reproductive Harm - www.P65Warnings.ca.gov

