

2992-066-000
Sensor Faucet Installation and care guide

■ Mounting Dimension

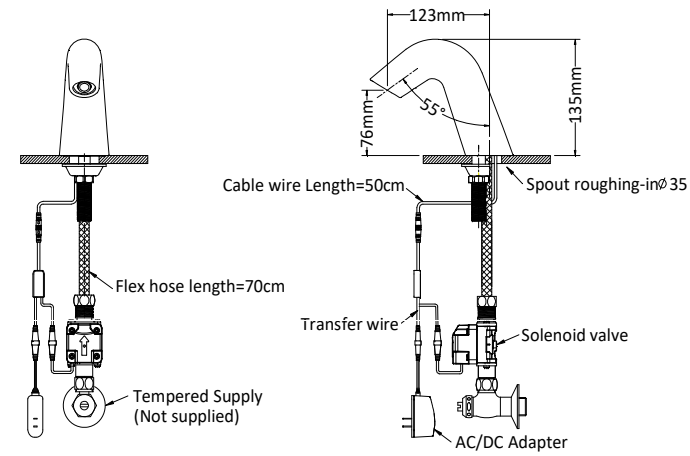

■ Specifications

Model	2992-066-000
Product	Sensor Faucet
Material and finish	Chrome Plated Cast Brass
Power Supply	AC100V ~ AC240V 50/60Hz
Power Consumption	Below 5W
Sensing distance (range)	Adjusted automatically 5cm ~ 20 cm
Safety mechanism (Operation Duration)	Water flow stops after continuous use for 60 seconds
Delay time	0.5 - 1 second
Applicable water pressure	10-100 PSI
Flow Rate	0.5 GPM (1.9 L/min)
Applicable water temperature	4° ~ 65°C (no icing)
Inner diameter	PF 1/2
Ceramic bore diameter	\varnothing 28 ~ \varnothing 35

■ Operation

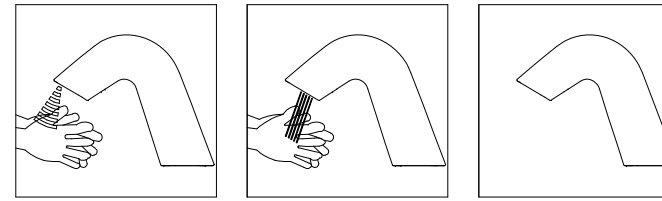

1. Place hands under the faucet sensor to activate solenoid valve.
2. Water begins to flow as soon as solenoid valve is activated.
3. Move hand away from sensor. Water flow stops after one second.

■ Care and cleaning

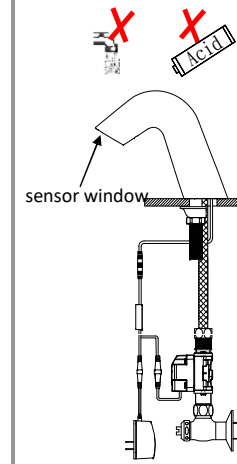

1. Infrared sensor window should remain clean at all times to ensure sensor functions properly.
2. Do not spray water directly on surfaces that may result in short circuit. Do not use abrasive cleaner that may scratch and dull the surface. Use a soft dampened cloth to wipe surfaces clean.
3. Clean the filter every 3 to 6 months, depending on the water quality, to prevent weak water flow.

■ Installation Instructions



- (1) Remove nut, faucet retainer.(keep oring)

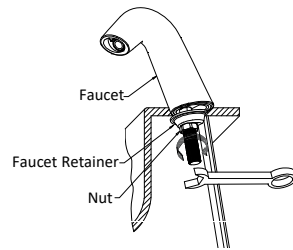

- (2) Firmly secure faucet and oring by tools on lavatory or deck hole. Use tools to fix components locking.

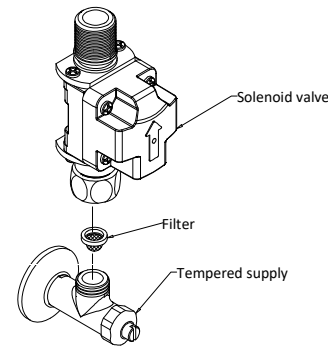

- (3) Connect solenoid valve with tempered supply as illustrated.

※ Important: Do not forget to install the filter to prevent debris from entering the solenoid valve as to maintain good water quality and prevent clogging. Poor water quality can result in reduced water flow.

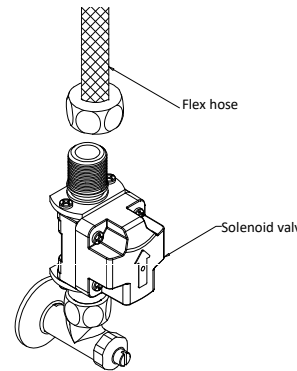

- (4) Connect solenoid valve with flex hose.

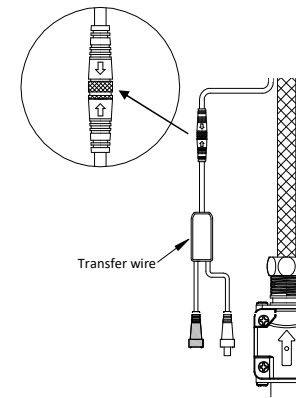

- (5) Connect sensor connector and transfer wire as illustrated. Before doing so, make sure you can see the arrows facing up and pointing at each other. Turn the medal ring in between, clockwise to tighten.

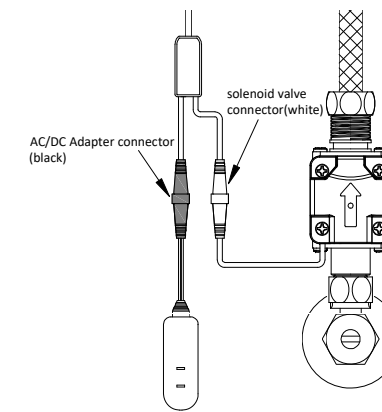

- (6) Connect the AC/DC adapter and solenoid valve as illustrated.

※Caution: Color matching is critical. Do not mix black and white when connecting.

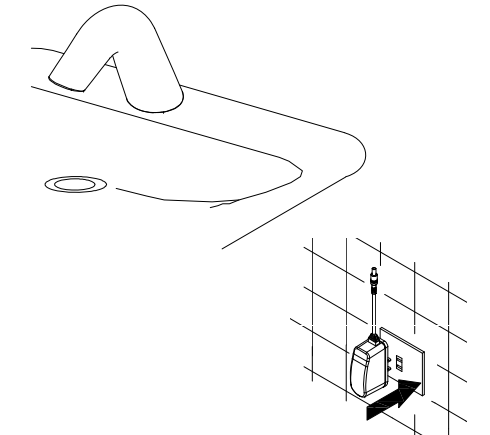

- (7) a. Make sure there are not any objects in the sensing area, including the sink and counter.Next, plug in the AC/DC adapter, step out of the sensing range for at least 3 seconds to allow it to automatically adjust and set proper sensing distance. This process should take only 3 seconds.
b. Turn on the water by turning the tempered supply to test the operation.

*Examine the quality of the water supply.
· Before installation, check the water pipe and remove any debris in the pipe to prevent from clogging and possibly result in product malfunction

■ Cleaning Filter and Adjusting Water Flow

■ Sensor Range Adjustment (automatically adjusted and set)

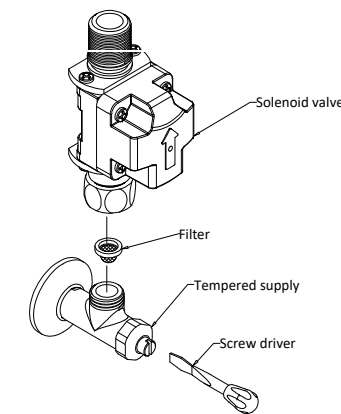

- Cleaning filter**
1. Turn off the water supply by turning the tempered supply with a screwdriver.
 2. Remove solenoid valve, remove filter, clean filter. Now re-assemble in a reverse order.

Adjusting Water Volume
Use a screwdriver to turn the tempered supply, clockwise to increase, anti-clockwise to decrease.

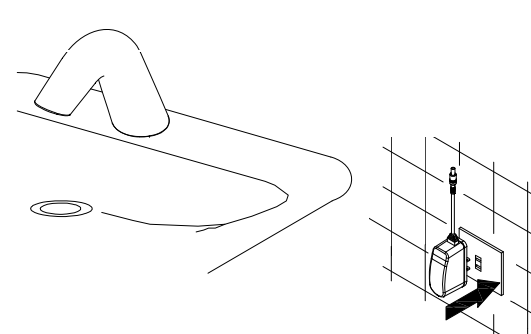

1. Make sure there are not any objects in the sensing area.
2. Unplug the AC adapter and leave it unplugged for at least one minute
3. Plug back in the AC adapter. Step out of the sensing range for a minimum of 3 seconds,after which the setting will be completed.

■ Troubleshooting

Situation	Possible Cause	Solution
No function, LED flashes	1. Dirty Sensor Window	1. Wipe clean Infrared window with tissue paper
No function (No LED light when sensing)	1. Loose power connection	1. Check power connection. Make sure it's properly connected
	2. AC/DC adapter failure	2. Replace AC/DC adapter
	3. Circuitry failure	3. Replace circuitry
No function (LED flashes once)	1. Water supply is turned off	1. Check water supply
	2. Loose solenoid valve connection	2. Check solenoid valve connection, reconnect if loose
	3. Solenoid valve failure	3. Replace solenoid valve
	4. Circuitry failure	4. Replace circuitry
Water keeps running	1. Dirty Sensor Window	1. Wipe clean sensor window with tissue paper
	2. Sensing range is set too long	2. Re-set sensing range
	3. Solenoid valve failure	3. Replace solenoid valve
Weak water flow	1. Weak water supply	1. Turn tempered supply to increase water volume
	2. Filtered obstructed	2. Clean filter
	3. Aerator obstructed	3. Clean aerator
Water flows when not in use	1. Dirty sensor window	1. Wipe clean sensor window with tissue paper
	2. Sensing range is set too long	2. Re-set sensing range

■ Parts Diagram

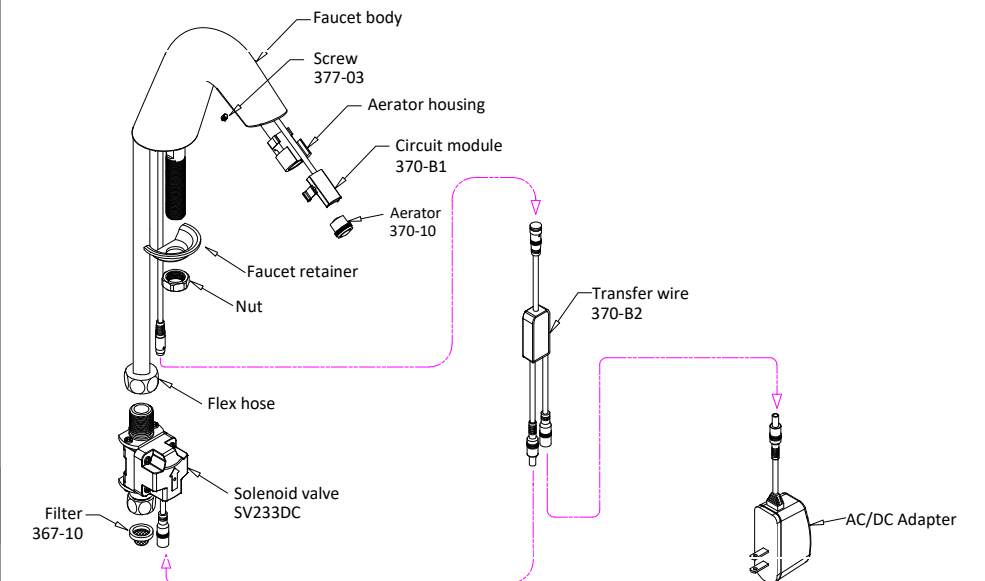

2992-066-000
Sensor Faucet Installation and care guide

■ Mounting Dimension

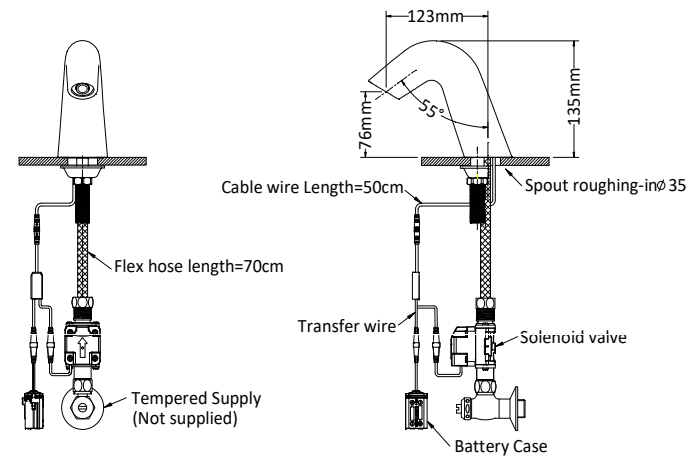

■ Specifications

Model	2992-066-000
Product	Sensor Faucet
Material and finish	Chrome Plated Cast Brass
Power Supply	4 x AA Alkaline Battery (DC 6V)
Power Consumption	Below 3W
Sensing distance (range)	Adjusted automatically 5cm ~ 20 cm
Safety mechanism (Operation Duration)	Water flow stops after continuous use for 60 seconds
Delay time	0.5 - 1 second
Applicable water pressure	10-100 PSI
Flow Rate	0.5 GPM (1.9 L/min)
Applicable water temperature	4° ~ 65°C (no icing)
Inner diameter	PF 1/2
Ceramic bore diameter	\varnothing 28 ~ \varnothing 35

■ Operation

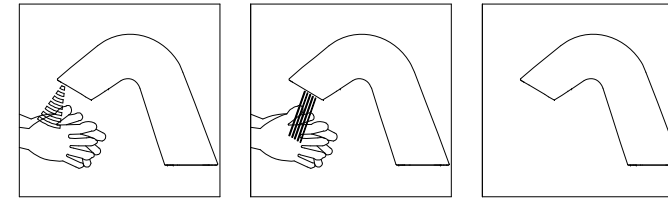

1. Place hands under the faucet sensor to activate solenoid valve.
2. Water begins to flow as soon as solenoid valve is activated.
3. Move hand away from sensor. Water flow stops after one second.

■ Care and cleaning

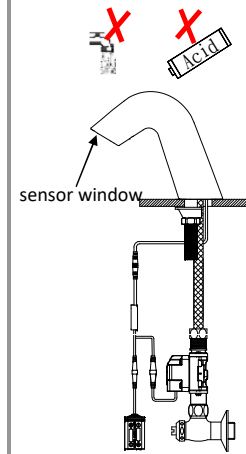

1. Infrared sensor window should remain clean at all times to ensure sensor functions properly.
2. Do not spray water directly on surfaces that may result in short circuit. Do not use abrasive cleaner that may scratch and dull the surface. Use a soft dampened cloth to wipe surfaces clean.
3. Clean the filter every 3 to 6 months, depending on the water quality, to prevent weak water flow.

■ Installation Instructions



(1) Remove nut, faucet retainer.(keep oring)

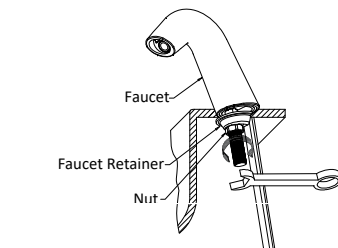

(2) Firmly secure faucet and oring by tools on lavatory or deck hole. Use tools to fix components locking.

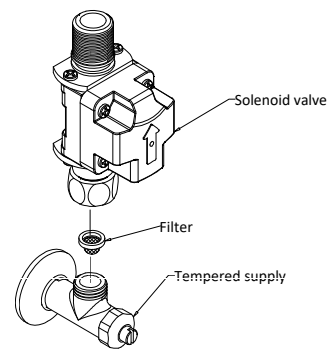

(3) Connect solenoid valve with tempered supply as illustrated.

※ Important: Do not forget to install the filter to prevent debris from entering the solenoid valve as to maintain good water quality and prevent clogging. Poor water quality can result in reduced water flow.

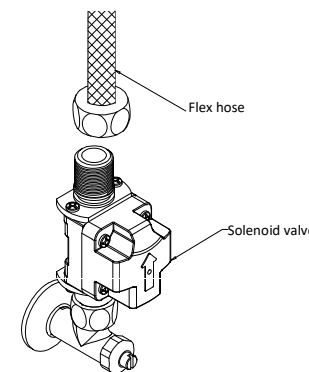

(4) Connect solenoid valve with flex hose.

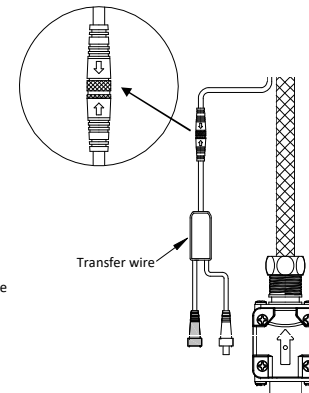

(5) Connect sensor connector and transfer wire as illustrated. Before doing so, make sure you can see the arrows facing up and pointing at each other. Turn the medal ring in between, clockwise to tighten.

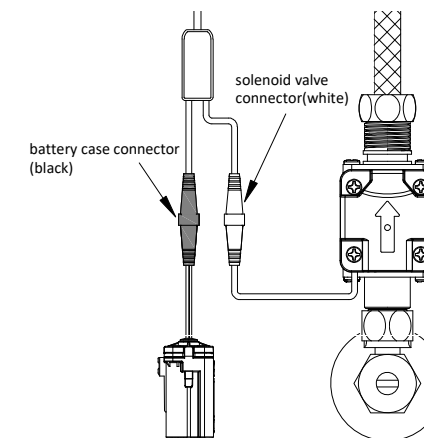

(6) Connect the battery case and solenoid valve as illustrated.

※Caution: Color matching is critical. Do not mix black and white when connecting.

※Screw or tape the battery case on a flat surface under the counter (sink) - secure with set screws or double-sided tape on the back of the battery case.

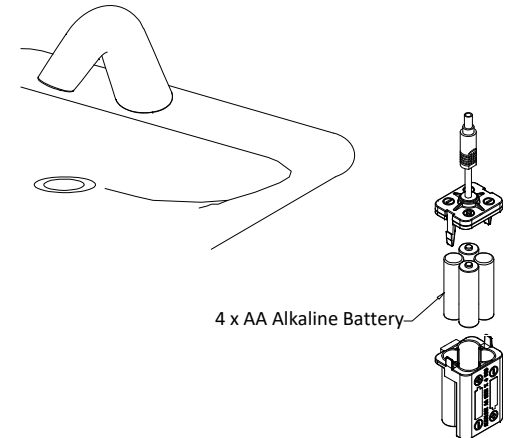

(7) a. Make sure there are not any objects in the sensing area, including the sink and counter. Place 4 AA Alkaline batteries in the case accordingly. Step out of the sensing range for at least 3 seconds to allow it to automatically adjust and set proper sensing distance. This process should take only 3 seconds.

b. Turn on the water by turning the tempered supply to test the operation.

*Examine the quality of the water supply.
· Before installation, check the water pipe and remove any debris in the pipe to prevent from clogging and possibly result in product malfunction

■ Cleaning Filter and Adjusting Water Flow

■ Replacing Battery

■ Sensor Range Adjustment (automatically adjusted and set)

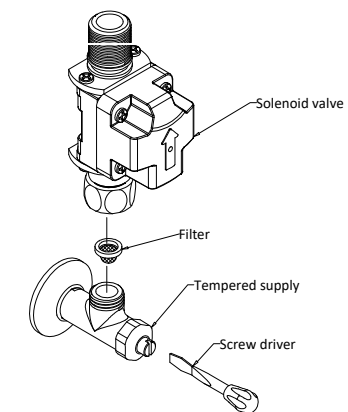

Cleaning filter
1. Turn off the water supply by turning the tempered supply with a screwdriver.
2. Remove solenoid valve, remove filter, clean filter. Now re-assemble in a reverse order.

Adjusting Water Volume
Use a screwdriver to turn the tempered supply, clockwise to increase, anti-clockwise to decrease.

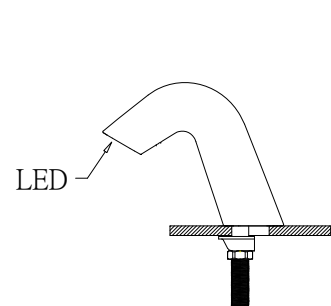

When the LED is flashing red, it is an indication of low battery and need to be replaced immediately.

※ Only Alkaline AA batteries should be used for this product.

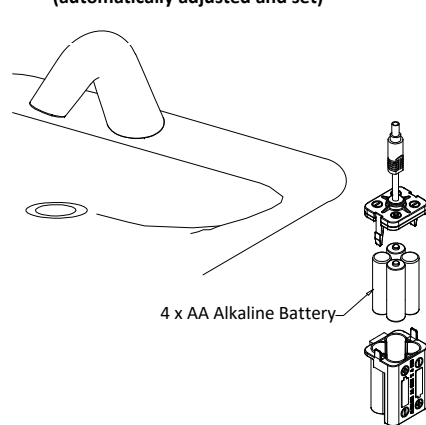

1. Remove all items (objects) in the sensing range, or surrounding area from counter.
2. Replace with 4 AA Alkaline batteries.
3. Step out of the sensing range for a minimum of 3 seconds, after which the setting will be completed.

■ Troubleshooting

Situation	Possible Cause	Solution
No function, LED flashes	1. Dirty Sensor Window	1. Wipe Infrared window clean with tissue paper
	2. Low(dead) battery	2. Replace battery
No function (No LED light when sensing)	1. Dirty Sensor Window	1. Wipe Clean Sensor Window
	2. Loose power connection	2. Check power connection. Make sure it's properly connected
	3. Low battery	3. Replace battery
	4. Circuitry failure	4. Replace circuitry
No function (LED flashes once)	1. Water supply is turned off	1. Check water supply
	2. Loose solenoid valve connection	2. Check solenoid valve connection, reconnect if loose
	3. Solenoid valve failure	3. Replace solenoid valve
	4. Circuitry failure	4. Replace circuitry
Water keeps running	1. Dirty Sensor Window	1. Wipe clean sensor window with tissue paper
	2. Sensing range is set too long	2. Re-set sensing range
	3. Solenoid valve failure	3. Replace solenoid valve
Weak water flow	1. Weak water supply	1. Turn tempered supply to increase water volume
	2. Filtered obstructed	2. Clean filter
	3. Aerator obstructed	3. Clean aerator
Water flows when not in use	1. Dirty sensor window	1. Wipe clean sensor window with tissue paper
	2. Sensing range is set too long	2. Re-set sensing range

■ Parts Diagram

