

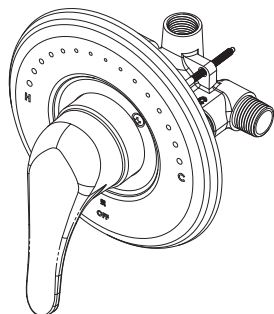

## Type 8: T/P Temperature/ Pressure Balancing Mixing Valve



OPTIONAL -LVR LEVER HANDLE

1/2" NPT FEMALE  
RISER AND TUB  
CONNECTIONS

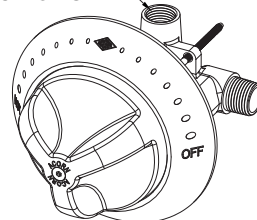

COMBINATION 1/2" NPT MALE  
& 1/2" SWEAT INLET SOCKET  
CONNECTIONS

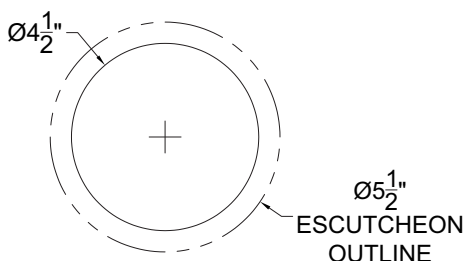

REQUIRED WALL  
OPENING

STANDARD PATENTED ADA  
COMPLIANT TRI-LEVER  
LIGATURE RESISTANT HANDLE

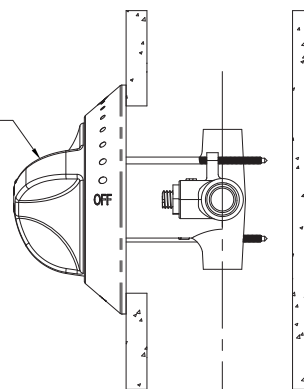

MIN. 1-3/4"  
MAX. 2-1/2"

SIDE VIEW

ASSE  
1016



- Patented D697,591
- D Acorn Engineering Co.

### T/P Mixing Valve:

The T/P Mixing valve automatically mixes hot and cold water to deliver blended water within a specific range. Using an advanced thermal actuator, the valve quickly compensates for temperature fluctuations induced by water temperature and pressure changes. In the event of cold water failure the thermostatic motor virtually shuts off the flow of hot water. The T/P Mixing Valve meets the most stringent performance criteria for temperature and pressure changes, defined by ASSE 1016 (**Rev. 2011** for Type T/P).

Featuring heavy, cast-brass construction and an adjustable temperature stop, self-contained cartridge, corrosion resistant internal components, non-rising stem, ceramic shut-off components and integral check stops to isolate individual valves for servicing and to prevent backflow. All parts of the valve are accessible from the front.

### Valve Specifications:

Valve Construction.....Combination mixing valve, is lead free solid brass body with corrosion resistant and lead free internal components.

Connections	Combination 1/2" NPT Male & 1/2" Sweat Inlet-Connections
Riser Connection	1/2" NPTI
Capacity	4 GPM (15 L/min)@ 45 PSI (310 kPa)
Max. Hot Water Supply Temp.	180°F (82°C)
Min. Hot Water Supply Temp.	10°F (5.5°C) Above-Set Point
Maximum Operating Pressure	125 PSIG (862kPa)
Temperature Ranges	ASSE 1016 T/P 85°-115°F (29-46°C) Adjustable Limit Stop (Factory Set at 110°F (43°C))
Maximum Operating Pressure	125 PSIG (862 kPa)
Minimum Flow	1.25 GPM (4.73 L/min)
Approval	CSA B125
Listing	ASSE 1016

Please visit [www.acorneng.com](http://www.acorneng.com) for most current specifications.

⚠ WARNING: Cancer and Reproductive Harm - [www.P65Warnings.ca.gov](http://www.P65Warnings.ca.gov)

**TYPE 8**

Revised: 08/29/18