

Model S0000-STK

Emergency Shower Test Kit



SPECIFICATIONS:

Model S0000-STK is a shower test kit which includes an extended rod, a corrosion resistant ring, a tubular shaped yellow waterproof chute to guide the water and a 5 gallon bucket. This device is designed to assist in the periodic testing of emergency showers.

Model: S0000-STK



OPTIONAL ACCESSORIES:

Additional costs may be incurred

NONE



Member of
U.S. Green
Building Council



Recyclable
Product

Acorn Safety assumes no responsibility for use of void or superseded data. © Copyright Acorn Safety®, City of Industry, CA, Division of Acorn Engineering Company®, Member of Morris Group International™. Please visit www.acorneng.com for most current specifications.

Submittal # **S0000-STK**
[ACC] Date: 08/30/17

Product complies
to the following standards:



Division of
Acorn Engineering Company®,
Member of
Morris Group International™

ACORN SAFETY

P.O. Box 3527
City of Industry, CA
91744 U.S.A.
Phone 800-591-9372
626-855-4804

www.acorneng.com

TECHNICAL DIMENSIONS

All dimensions are subject to manufacturer's tolerance of plus or minus 1/2" nominal and subject to change without notice. Acorn Safety® assumes no responsibility for use of void or superseded data. Dimensions may change with the addition of optional accessories. © Acorn Safety®, A Division of Acorn Engineering Company®, Member of Morris Group International™. Please visit www.acorneng.com for most current specifications.

Model S0000-STK : Emergency Shower Test Kit

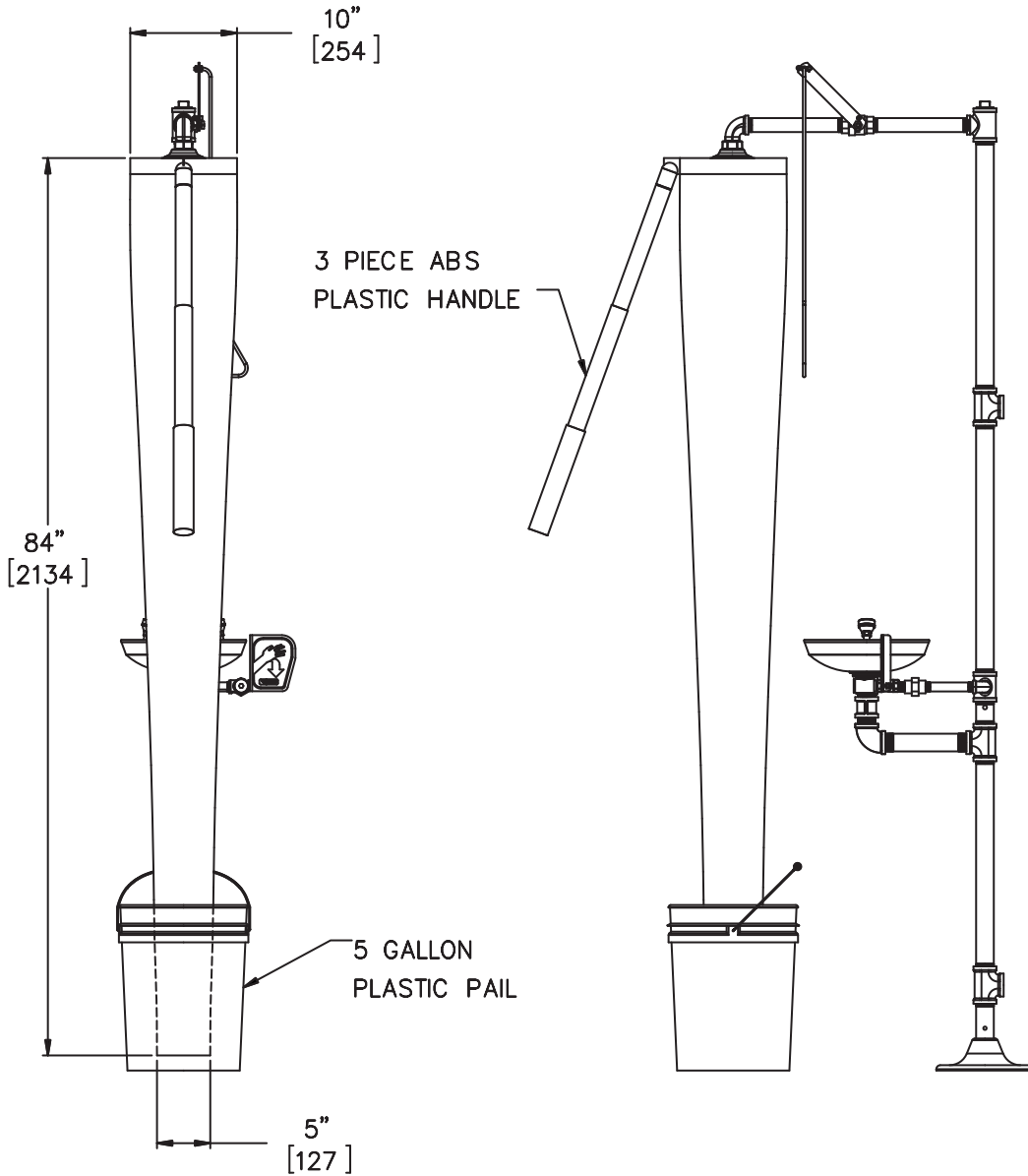

NOTES:

1. ALL DIMENSIONS ARE INCHES [MM].
2. SHOWN INSTALLED ON A COMBINATION SHOWER AND EYEWASH, NOT INCLUDED.

⚠ WARNING: Cancer and Reproductive Harm - www.P65Warnings.ca.gov

S0000-STK Date: 08/30/17

Acorn Safety warrants that its products are free from defects in material or workmanship under normal use and service for a period of one year from date of shipment. Acorn's liability under this warranty shall be discharged solely by replacement or repair of defective material, provided Acorn is notified in writing within one year from date of shipment, F.O.B. Industry, California.

SELECTION SUMMARY & APPROVAL FOR MANUFACTURING

Model Number & Options _____ Quantity _____

Company _____

Contact _____ Title _____

Signature (Approval for Manufacturing) _____ Date _____



800-591-9372
or 626-855-4804
www.acorneng.com